

REPAIR MANUAL



SELF-PROPELLED TELESCOPIC PLATFORM H21T(X) - H23T(X) - H23TP(X) - H25TP(X)

242 031 9590 - E 10.02 GB



ISO 9001
GROUPE
PINGUELY
HAULOTTE



ARTICULEES



MATS



TELESCOPIQUES



CISEAUX



TRACTEES

Haulotte 

L'ACCES A L'ESPACE

PINGUELY HAULOTTE • LA PERONNIERE - BP 9 - 42152 L'HORME • Tél. +33 (0) 4 77 29 24 24 • Fax SAV +33 (0) 4 77 31 28 11
email haulotte@haulotte.com • Web www.haulotte.com

GENERAL

This manual gives the information required for you to perform servicing and repair operations on certain pieces of equipment yourself.

However, we would like to bring your attention to the importance of:

- respecting the safety instructions concerning the machine itself, its use and its environment,
- use within the limits of its performance,
- correct servicing to ensure long service life.

During and after the guarantee period, our After-Sales service is available to perform any servicing operations you may require.

In this case, contact our local agency or our Plant After-Sales service, specifying the exact type of machine and its serial number.

To order consumables or spare parts, use the "Instructions for use and maintenance" manual and the "Spare parts" catalogue to order original parts, the only guarantee of interchangeability and perfect operation.

REMINDER: We would like to remind you that our machines comply with the clauses of the "Machines Directive", 89/392/CEE, dated June 14th 1989, modified by directives 91/368/CEE, dated June 21st 1991, 93/44/CEE, dated June 14th 1993, 93/68/CEE (98/37/CE) dated July 22nd 1993 and 89/336 CEE, dated May 3rd 1989; to directive 2000/14/CE and directive EMC/89/336/CE.



Caution!

The technical data in this manual is not binding and we reserve the right to make improvements or modifications without altering this manual.

SUMMARY

GENERAL		1
1 - GENERAL RECOMMENDATIONS - SAFETY		1
1.1 - GENERAL WARNING		1
1.1.1 - Manual		1
1.1.2 - Label		1
1.1.3 - Safety		1
1.2 - GENERAL SAFETY INSTRUCTIONS		2
1.2.1 - Operators		2
1.2.2 - Environment		2
1.2.3 - Using the machine		2
1.3 - RESIDUAL RISKS		4
1.3.1 - Risks of jerky movements and tipping over		4
1.3.2 - Electrical risk		4
1.3.3 - Risk of explosion or burning		4
1.3.4 - Risks of collision		4
1.4 - INSPECTIONS		5
1.4.1 - Periodic inspections		5
1.4.2 - Examination of machine suitability		5
1.4.3 - State of conservation		5
1.5 - REPAIRS AND ADJUSTMENTS		6
1.6 - VERIFICATIONS WHEN RETURNING TO SERVICE		6
1.7 - BEAUFORT SCALE		6
2 - SPECIFICATION		7
2.1 - TECHNICAL DATA		8
2.1.1 - H21T(X) and H23TP(X) technical data		8
2.1.2 - H23T(X) and H25TP(X) technical data		9
2.2 - DIMENSIONS		10

2.2.1 -	H21T(X) dimensions.....	10
2.2.2 -	H23TP(X) dimensions	11
2.2.3 -	H23T(X) dimensions.....	12
2.2.4 -	H25TP(X) dimensions	13
2.3 -	TIGHTENING TORQUE VALUES	14
2.3.1 -	Tightening torque values for large threading.....	14
2.3.2 -	Tightening torque values for narrow threading.....	14
2.3.3 -	Tightening torque values for wheels.....	14
2.3.4 -	Tightening torque values for hydraulic hoses	15
2.3.5 -	Pressure values (in bar)	16
2.3.6 -	Adjustment time	16
3 -	SAFETY SYSTEM	17
3.1 -	FUNCTION OF RELAYS AND FUSES IN TURNTABLE BOX	17
3.2 -	FUNCTION OF SAFETY CONTACTS	17
3.3 -	POSITIONS OF ELECTRIC CONTACTS	18
3.4 -	OPERATING EQUATIONS	19
4 -	WIRING DIAGRAMS	21
4.1 -	DIAGRAM E 455 - FOLIO 01/05	21
4.2 -	POSITIONS OF ELECTRIC COMPONENTS ON THE MOTHER BOARD	26
4.2.1 -	Description	26
4.2.2 -	Positions of screws, connectors and relays	27
4.2.3 -	Positions of fuses	28
4.2.4 -	Positions of diagnosis help LEDs	29
5 -	HYDRAULIC DIAGRAMS	31
5.1 -	DIAGRAM H21T / H23T REFERENCE B15714	31
5.2 -	DIAGRAM H21TX / H23TX REFERENCE B15713	32
5.3 -	DIAGRAM H23TP / H25TP REFERENCE B15330	33
5.4 -	DIAGRAM H23TPX / H25TPX REFERENCE B15331.....	34
5.5 -	FUNCTIONS OF ELECTROVALVES	35

5.5.1 - "On/off" electrovalves.....	35
5.5.2 - Proportional electrovalves.....	35
6 - MAINTENANCE	37
6.1 - GENERAL RECOMMENDATIONS	37
6.2 - SPECIFIC RECOMMENDATIONS.....	37
6.2.1 - Specific tools.....	37
6.2.2 - Replacing an element	37
6.2.3 - Locating the breakdown.....	38
6.2.4 - Environment protection	38
6.3 - MAINTENANCE SYSTEM.....	38
6.4 - ELECTRIC POWER SUPPLY	38
6.5 - MAINTENANCE PLAN	39
6.6 - OPERATIONS	41
6.6.1 - Summary table.....	41
6.7 - PRESENCE OF LABELS	42
6.7.1 - "Yellow" labels	43
6.7.2 - "Orange" labels	43
6.7.3 - "Red" labels	44
6.7.4 - Other labels.....	45
6.7.5 - Option	45
6.7.6 - Positions of labels	46
6.7.7 - Positionnement des étiquet.....	47
6.8 - PRESENCE OF MANUALS.....	48
7 - PREVENTIVE MAINTENANCE SHEETS.....	49

8 -	OPERATING INCIDENTS	57
8.1 -	INCIDENT TABLE	57
8.1.1 -	General operation.....	58
8.1.2 -	Lifting system	60
8.1.3 -	Travel system	61
8.1.4 -	Steering system.....	61
8.1.5 -	Turntable rotation system.....	62
8.2 -	BREAKDOWN DETECTION FLOW CHARTS.....	62
9 -	CORRECTIVE MAINTENANCE PROCEDURE	139

1 - GENERAL RECOMMENDATIONS - SAFETY

1.1 - GENERAL WARNING

1.1.1 - Manual

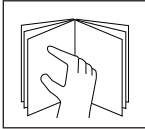

This manual aims to help maintenance personnel service and repair the machine. It cannot, however, replace the basic training required by any person working on the site equipment.

The site manager must inform operators of the recommendations in the instruction manual. He is also responsible for application of current "user regulations" in the country of use.

Before operating on the machine, it is essential to be familiar with all the recommendations in this manual and the user manual to ensure personnel and equipment safety.

1.1.2 - Label



Potential dangers and recommendations for the machine are indicated on labels and plates. Read the instructions on them.

All labels conform to the following colour code:

- Red indicates a potentially fatal danger.
- Orange indicates a danger that may cause serious injury.
- Yellow indicates a danger that may cause material damage or slight injury.

Maintenance personnel must ensure that these labels and plates are in good conditions and keep them legible. Spare labels and plates can be supplied by the manufacturer on request.

1.1.3 - Safety

Ensure that any person entrusted with the machine is take the safety measures implied by its use.

Avoid any working mode that may affect safety. Any use that does not comply with the recommendations may generate risks and damage to people and equipment.

After intervention, maintenance personnel must check that the operator manual is present. This must be kept by the user throughout the machine's service life, even if it is loaned, rented or sold.

Ensure that all the plates or labels related to safety and danger are complete and legible.



Caution !

To attract the reader's attention, instructions are indicated by this standardised sign.

1.2 - GENERAL SAFETY INSTRUCTIONS

1.2.1 - Operators

Operators must be aged over 18, and hold an operating permit issued by their employer after undergoing a medical check and a practical test that prove they are apt to operate the machine.



Caution !

Only trained operators can use Haulotte self-propelled platforms.

There must always be at least two operators present, so that one can always:

- Take fast action if necessary.
- Take over the controls in case of accident or malfunction.
- Monitor and prevent movement of vehicles and people near the platform.
- Guide the platform operator if required.

1.2.2 - Environment

Never use the machine:

- On ground that is soft, unstable, congested.
- On a ground that has a slope greater than permissible limit.
- In winds greater than the permissible limit. If used outside, use an anemometer to ensure that the wind speed does not exceed the permissible limit.
- Near power lines (check minimum safe approach distances according to voltage carried)
- In temperatures less than -15°C (especially in refrigerated chambers). Consult us if it is necessary to work below -15°C .
- In explosive atmospheres.
- In poorly-ventilated areas, since the exhaust fumes are toxic.
- During storms (risk of lightning).
- In the dark, unless the optional floodlight is fitted.
- In the presence of intense electromagnetic fields (radar, moving and high currents).

DRIVING ON PUBLIC ROADS IS PROHIBITED.

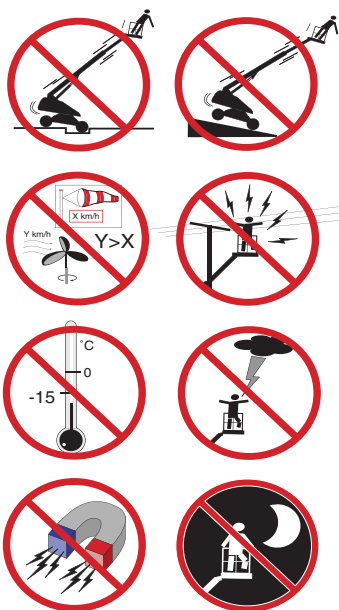

1.2.3 - Using the machine

Do not use the machine:

- with a load greater than allowed load,
- if wind speed exceeds the maximum,
- with more than maximum authorised number of occupants in platform,
- with a side load in the platform greater than permissible limit.

To reduce the risks of **serious falls**, operators **must respect the following instructions**:

- Hold the guardrail firmly when lifting or driving the platform.
- Remove any traces of oil or grease from the platform steps, floor or guardrails.
- Wear personal protective equipment suited to working conditions and conform to local regulations, particularly when working in hazardous areas.
- Never disable the limit switches of the safety devices.
- Avoid contact with stationary or moving obstacles
- Do not increase the platform operating height by means of ladders or other accessories.
- Never use the guardrails to climb into or out of the platform (use the steps provided).
- Never climb on the guardrails when the platform is up.
- Avoid driving the machine at high speed in narrow or congested areas.
- Never use the machine without putting in place the platform safety bar or closing the safety gate.
- Never climb on the covers.



Caution !

Never use the platform as a crane, hoist or lift.

Never use the machine to pull or tow.

Never use the boom as a ram or thruster or to lift the wheels



To reduce the risks of tipping over, operators **must follow these instructions**:

- Never disable the limit switches of the safety devices.
- Never move the control handles from one direction to the other without stopping in the «O» position. (To stop when travelling, gradually move the handle to «O», keeping your foot down on the pedal.)
- Do not exceed the maximum load or the number of occupants allowed in the platform.
- Spread the load and if possible place in the centre of the platform.
- Check that the ground resists the pressure and load per wheel.
- Avoid contact with stationary or moving obstacles.
- Do not drive the platform at high speed in narrow or congested areas.
- Avoid contact with stationary or moving obstructions.
- Do not drive the platform in reverse gear (poor visibility).
- Do not use the machine with a congested platform.
- Do not use the machine with equipment or objects hanging from the guardrails or boom.
- Do not use the machine with items liable to increase the wind load (e.g. panels).
- Never carry out maintenance on the machine with the platform raised, without first installing the required safety provisions (overhead crane, crane).
- Perform the daily checks and monitor the machine's good working order during periods of use.

NOTA : *Do not tow the platform (it is not designed to be towed and must be transported on a trailer).*

1.3 - RESIDUAL RISKS



Caution !

Operation direction may be inverted on a turntable machine after 180° rotation. Bear in mind the colour of the arrows on the chassis, in relation to the colour shown on the platform control panel (green and red).

Thus, moving the manipulator in the direction of the green arrow on the control panel will move the machine according to the direction indicated by the green arrow on the chassis. Similarly, moving a manipulator in the direction of the red arrow on the control panel, will move the machine in the direction of the red arrow on the chassis.



Caution !

If the machine has a 220 V 16A max. plug, the extension must be connected to a mains socket protected by a 30 mA differential circuit breaker.

1.3.1 - Risks of jerky movements and tipping over

Risks of jerky movement and tipping over are high in the following situations:

- Sudden action on the controls.
- Overloading of the platform.
- Uneven ground (Be careful during thaw periods in winter).
- Gusts of wind.
- Contact with an obstacle on the ground or at a height.
- Working on platforms, pavements, etc.

Allow sufficient stopping distances:

- 3 meters at high speed,
- 1 meter at low speed.

Allow sufficient stopping distances: 3 metres at high speed and 1 metre at low speed.

Do not alter or neutralise any components connected in any way to the machine's safety or stability.

Do not place or fasten a load so that it overhangs the machine's parts.

Do not touch adjacent structures with the elevator arm.

1.3.2 - Electrical risk

Electrical risks are high in the following situations:

- Contact with a live line (check safety distances before operation near electricity lines).
- Use during storms.

1.3.3 - Risk of explosion or burning

The risks of explosion or burning are high in the following situations:

- Working in explosive or inflammable atmosphere.
- Filling the fuel tank near naked flames.
- Contact with the hot parts of the motor.
- Use of a machine generating hydraulic leakage.

1.3.4 - Risks of collision

- Risk of crushing people in the machine operation zone (when travelling or manoeuvring equipment).
- The operator must assess the risks above him before using the machine.
- Pay attention to the position of the arms during turntable rotation.
- Adapt movement speed to conditions related to the ground, traffic, slope and movement of people, or any other factor that may cause a collision.
- When driving down the ramp of a truck, ensure sufficient space is available for safe unloading.
- Check brake pad wear regularly to avoid all risk of collision.

1.4 - INSPECTIONS

Comply with the national regulations in force in the country of machine use.
For FRANCE: Order dated 9 June 1993 + circular DRT 93 dated 22 September 1993 which specify:

1.4.1 - Periodic inspections

The machine must be inspected every 6 months in order to detect any defects liable to cause an accident.

These inspections are performed by an organisation or personnel specially designated by the site manager and under his responsibility (whether or not they belong to the company) Articles R 233-5 and R 233-11 of the French Labour Code.

The results of these inspections are recorded in a safety register kept by the site manager and constantly available to the labour inspector and the site safety committee (if one exists) and the list of specially designated personnel (Article R 233-5 of the French Labour Code).

Moreover, before each use, check the following:

- the operator's manual is in the storage compartment on the platform,
- the stickers are placed according to the section concerning "Labels and their positions",
- oil level and any elements in the maintenance operation table
- look out for any damaged, incorrectly installed, modified or missing parts.

NOTE : *This register can be obtained from trade organisations, and in some cases from the OPPBTP or private prevention agencies.*

The designated persons must be experienced in risk prevention (Articles R 233-11 or order n° 93-41).

No member of personnel is allowed to perform any check whatsoever during machine operation (Article R 233-11 of the French Labour Code).

1.4.2 - Examination of machine suitability

The manager of the site where the machine is operated must ensure the machine is suitable, i.e. capable of performing the work in complete safety, and in compliance with the operating manual. Furthermore, the French order of 9 June 1993 addresses problems relative to leasing, examination of the state of conservation, checking upon operation after repairs, and test conditions (static test coefficient 1.25; dynamic test coefficient 1.1). All users must consult this order's requirements and comply with them.

1.4.3 - State of conservation

Detect any deterioration liable to cause hazardous situations (concerning safety devices, load limiters, tilt sensor, cylinder leaks, deformation, welds, bolt tightness, hoses, electrical connections, tyre state, excessive mechanical gaps).

NOTA : *In the case of rental, the user of the rented device is responsible for the machine condition and suitability inspection. He must check with the renting party that the general periodic checks and checks prior to operation have been carried out.*

1.5 - REPAIRS AND ADJUSTMENTS

These cover major repairs, and work on or adjustments to safety systems or devices (of a mechanical, hydraulic or electrical nature).

These must be performed by personnel from or working for PINGUELY-HAULOTTE who will use only original parts.

Any modification not controlled by PINGUELY-HAULOTTE is unauthorised.

The manufacturer cannot be held responsible if non-original parts are used or if the work specified above is not performed by PINGUELY-HAULOTTE-approved personnel.

1.6 - VERIFICATIONS WHEN RETURNING TO SERVICE

To be performed after:

- extensive disassembly-reassembly operation,
- repair affecting the essential components of the machine.
- any accident caused by the failure of an essential component.

It is necessary to perform a suitability examination, a state of conservation examination, a static test, a dynamic test (see coefficient in paragraph 1.4.2, 5).

1.7 - BEAUFORT SCALE

The Beaufort Scale of wind force is accepted internationally and is used when communicating weather conditions. It consists of number 0 - 17, each representing a certain strength or velocity of wind at 10m (33 ft) above ground level in the open.

Description of Wind		Specifications for use on land	MPH	m/s
0	Calm	Calm; smoke rises vertically	0-1	0-0.2
1	Light Air	Direction of wind shown by smoke	1-5	0.3-1.5
2	Light Breeze	Wind felt on face; leaves rustle; ordinary vanes moved by wind	6-11	1.6-3.3
3	Gentle Breeze	Leaves and small twigs in constant motion; wind extends light flag	12-19	3.4-5.4
4	Moderate Breeze	Raises dust and loose paper; small Branches are moved	20-28	5.5-7.9
5	Fresh Breeze	Small trees in leaf begin to sway; crested wavelets form on inland waterways	29-38	8.0-10.7
6	Strong Breeze	Large branches in motion; whistling heard in telephone wires; umbrellas used with difficulty	39-49	10.8-13.8
7	Near Gale	Whole trees in motion; inconvenience felt when walking against wind	50-61	13.9-17.1
8	Gale	Breaks twigs off trees; generally impedes progress	62-74	17.2-20.7
9	Strong Gale	Slight structural damage occurs (chimney pots and slates removed)	75-88	20.8-24.4

2 - SPECIFICATION

The self-propelled elevating work platforms, models H21T(X), H23T(X), H23TP(X), H25TP(X), are designed to carry out all kinds of overhead work within the limits imposed by their characteristics (see "Operation and maintenance instruction manual", and Chapitre 2.1, page 8) and provided that all safety instructions relating to the equipment and environment of use are respected.

The main control panel is situated in the platform.

The control panel situated on the turntable is to be used in emergencies or cases of machine breakdown.

REMINDER: When requesting information, intervention or spare parts, you
will need to specify the machine type and serial number.

2.1 - TECHNICAL DATA

2.1.1 - H21T(X) and H23TP(X) technical data

DESCRIPTION	H21T	H21TX	H23TP	H23TPX
Load	360 kg including 3 people		250 kg including 2 people	
Maximum side manual force	40 kg			
Max. wind speed	60 km/h			
Floor height	18.8 m	18.8 m	20.6 m	20.6 m
Working height	20.8 m	20.8 m	22.6 m	22.6 m
Overall length	8.91 m	8.91 m	11.05 m	11.05 m
Overall width	2.47 m			
Overall height	2.84 m			
Wheelbase	2.49 m			
Floor clearance	340 mm			
Max. reach	16.66 m	16.66 m	19.5 m	19.5 m
Boom displacement	+75° -15°			
Telescoping (stroke)	4.76 m			
Turntable rotation	Continuous			
Reducing gear	22.4			
Max. slope in travel	40%			
Tyre dimensions	15 R 22			
External turning radius	6.15 m			
Tilt sensor	5° (approx. 9%)			
Hydraulic tank	150 l			
Diesel tank	150 l			
Total weight	13100 kg	13100 kg	13750 kg	13750 kg
Number of drive wheels	2	4	2	4
Number of steering whels	2			
Differential blocking system	YES			
Hydraulic brakes	YES			
Freewheel	YES			
Tightening torque:				
- wheel nuts	32 m.daN			
- slew ring nuts	27 m.daN			
Vibrations:				
- at foot level	< 0.5 m/s ²			
- at hand level	< 2.5 m/s ²			
DEUTZ diesel motor	Type 3L41C			
- Power	43.6 CH / 32.1 kW to 2400 rpm			
- Idling power	33.3 CH / 22.9 kW to 1500 rpm			
- Consumption	11.5 l/h			
- Idling consumption	6.8 l/h			
Hydraulic pump 45 cm ³ /rev	85 l/min max. (LOADSENSING)			
Hydraulic pressure:				
- General	240 bars			
- Travel	240 bars			
- Steering	240 bars			
- Rotation	100 bars			
- Equipment	240 bars			
Travel speed	LS=1.5 km/h - HS=5 km/h			
Max. force on one wheel	8000 daN			
Max. pressure on the ground	with 250 kg			
- concrete	18 daN/cm ²			
- soft ground (beaten earth)	8 daN/cm ²			
Starter battery	1 x 12 V - 95 A.h			
Supply voltage	12 V			
Acoustic power	99 dB(A)			
Sound level at 10 m	66.5 dB(A)			

2.1.2 - H23T(X) and H25TP(X) technical data

DESCRIPTION	H23T	H23TX	H25TP	H25TPX
Nominal load	250 kg including 2 people			
Maximum side manual force	40 kg			
Max. wind speed	60 km/h			
Floor height	21.3 m	21.3 m	23 m	23 m
Working height	23.3 m	23.3 m	25 m	25 m
Overall length	11.05 m	11.05 m	12.87 m	12.87 m
Overall width	2.48 m			
Overall height	3.10 m			
Wheelbase	2.49 m			
Floor clearance	340 mm			
Max. reach	19.5 m	19.5 m	17.5 m	17.5 m
Boom displacement	+75° -15°			
Telescoping (stroke)	4.76 m			
Turntable rotation	Continuous			
Reducing gear	22.4			
Max. slope in travel	40%			
Tyre dimensions	15 R 22			
External turning radius	6.15 m			
Tilt sensor	5° (approx. 9%)			
Hydraulic tank	150 l			
Diesel tank	150 l			
Total weight	13750 kg	13750 kg	13850 kg	13850 kg
Number of drive wheels	2	4	2	4
Number of steering whels	2			
Differential blocking system	YES			
Hydraulic brakes	YES			
Freewheel	YES			
Tightening torque:				
- wheel nuts	32 m.daN			
- slew ring nuts	27 m.daN			
Vibrations:				
- at foot level	< 0.5 m/s ²			
- at hand level	< 2.5 m/s ²			
DEUTZ diesel motor	Type 3L41C			
- Power	43.6 CH / 32.1 kW at 2400 rpm			
- Idling power	33.3 CH / 22.9 kW at 1500 rpm			
- Consumption	11.5 l/h			
- Idling consumption	6.8 l/h			
Hydraulic pump 45 cm ³ /rev	85 l/min max (LOADSENSING)			
Hydraulic pressure:				
- General	240 bars			
- Travel	240 bars			
- Steering	240 bars			
- Rotation	100 bars			
- Equipment	240 bars			
Travel speed	LS=1.5 km/h - HS=5 km/h			
Max. force on one wheel	8000 daN			
Max. pressure on the ground	with 250 kg			
- concrete	18 daN/cm ²			
- soft ground (beaten earth)	8 daN/cm ²			
Starter battery	1 x 12 V - 95 A.h			
Supply voltage	12 V			
Acoustic power	99 dB(A)			
Sound level at 10 m	66.5 dB(A)			

2.2 - DIMENSIONS

2.2.1 - H21T(X) dimensions

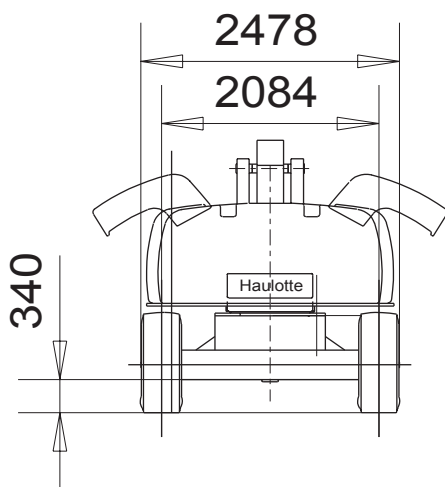
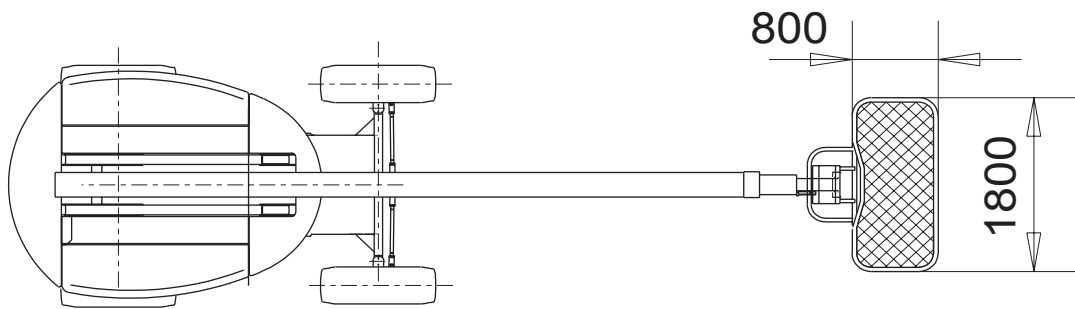
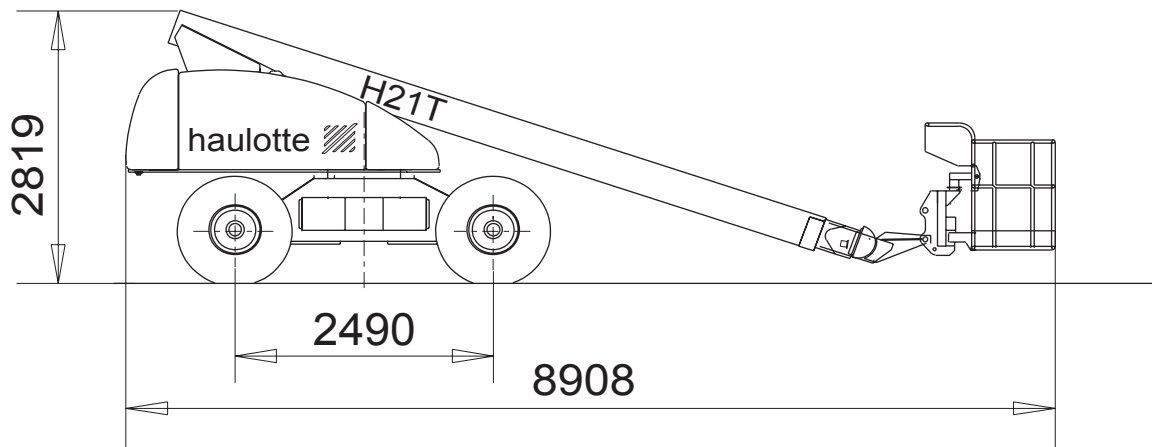

2.2.2 - H23TP(X) dimensions

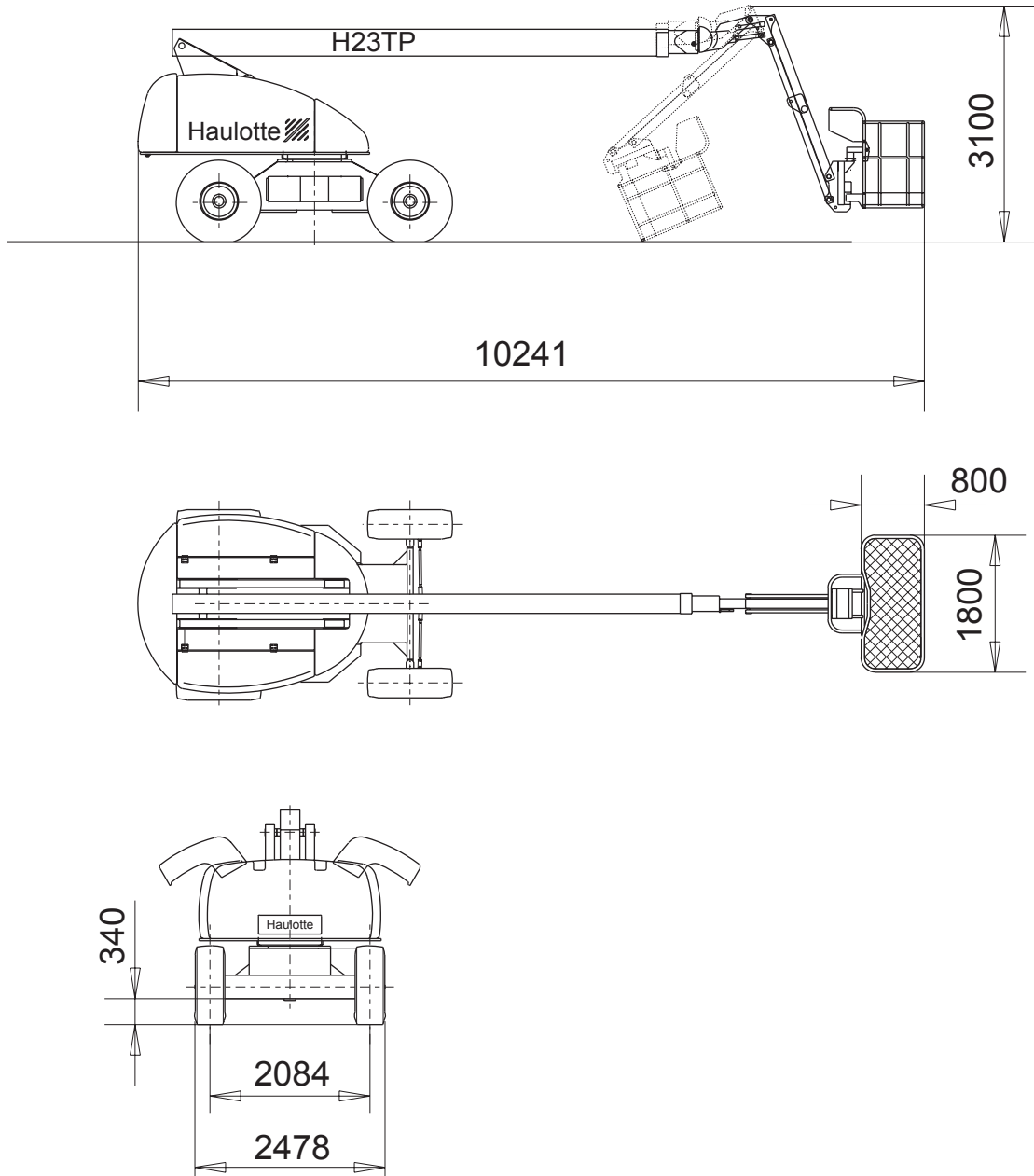

2.2.3 - H23T(X) dimensions

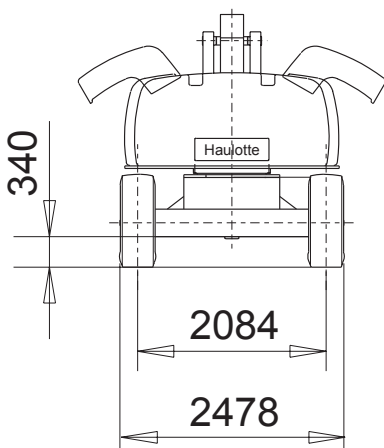
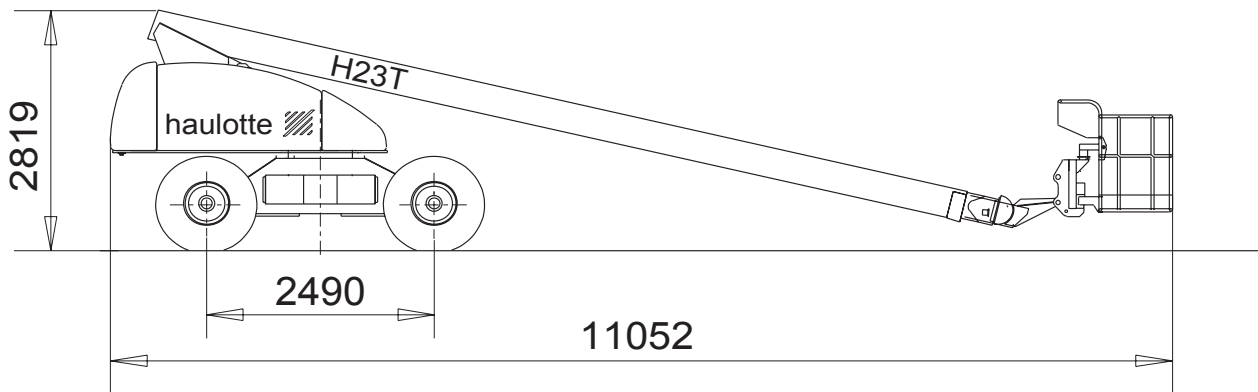

2.2.4 - H25TP(X) dimensions

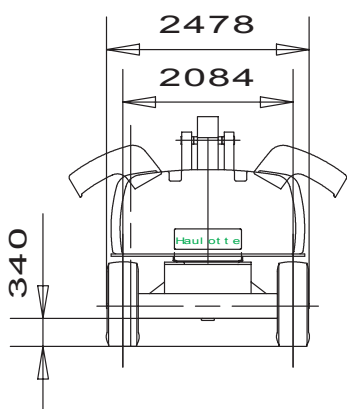
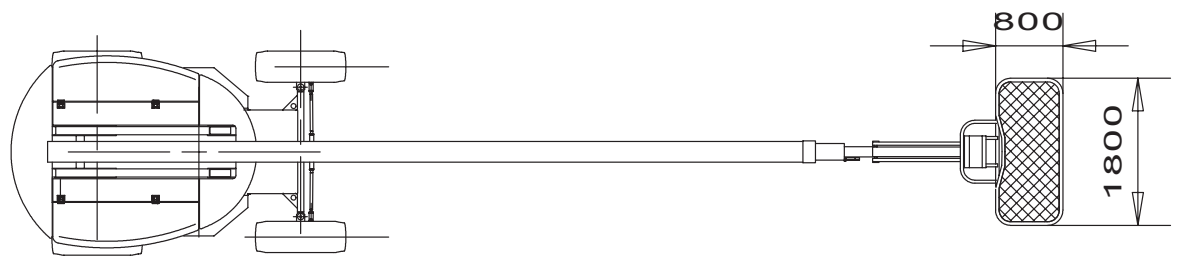
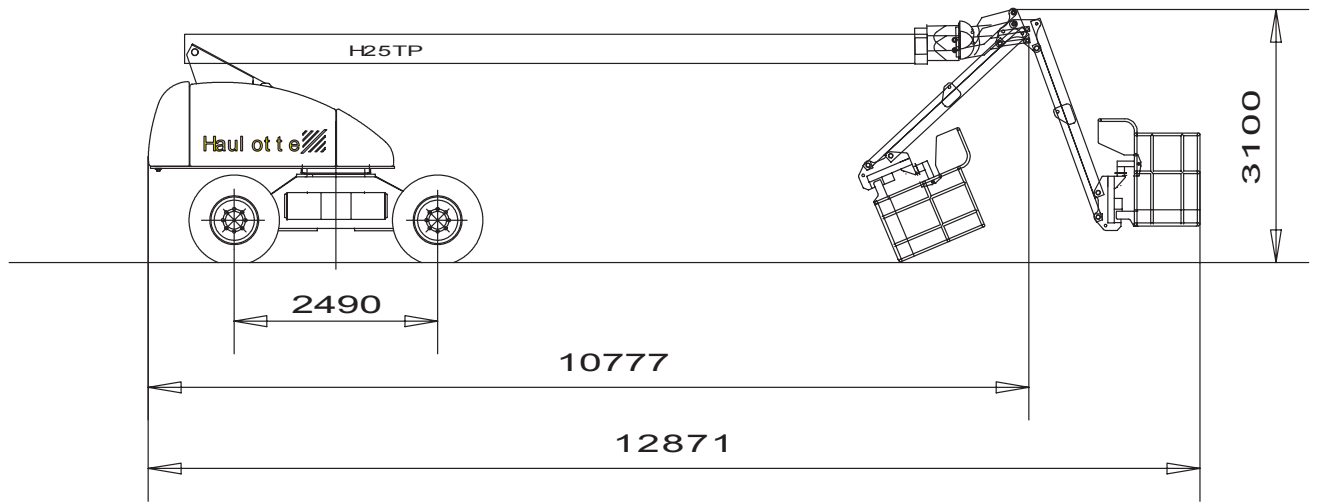

2.3 - TIGHTENING TORQUE VALUES

2.3.1 - Tightening torque values for large threading

<i>Nominal diameter</i>	<i>Tightening torque in N.M</i>		
	8.8	10.9	12.9
M 6*1	9 to 11	13 to 14	15 to 17
M 7*1	15 to 19	21 to 24	26 to 28
M 8*1.25	22 to 27	31 to 34	37 to 41
M 10*1.5	43 to 45	61 to 67	73 to 81
M 12*1.75	75 to 94	110 to 120	130 to 140
M 14*2	120 to 150	170 to 190	200 to 220
M 16*2	190 to 230	260 to 290	320 to 350
M 18*2.5	260 to 320	360 to 400	440 to 480
M 20*2.5	370 to 450	520 to 570	620 to 680
M 22*2.5	500 to 620	700 to 770	840 to 930
M 24.3*3	630 to 790	890 to 990	1070 to 1180
M 27*3	930 to 1150	1300 to 1400	1560 to 1730
M 30*3.5	1260 to 1570	1770 to 1960	2200 to 2350

2.3.2 - Tightening torque values for narrow threading

<i>Nominal diameter</i>	<i>Tightening torque in N.M</i>		
	8.8	10.9	12.9
M 8*1	24 to 29	33 to 37	40 to 44
M 10*1.25	46 to 57	64 to 71	77 to 85
M 12*1.25	83 to 100	120 to 130	140 to 150
M 14*1.5	130 to 160	180 to 200	220 to 240
M 16*1.5	200 to 250	280 to 310	340 to 370
M 18*1.5	290 to 360	410 to 450	490 to 540
M 20*1.5	410 to 510	570 to 630	690 to 760
M 22*1.5	550 to 680	780 to 870	920 to 1000
M 24*1.5	690 to 860	970 to 1070	1160 to 1290
M 27*2	1000 to 1300	1400 to 1560	1690 to 1880
M 30*2	1400 to 1700	1960 to 2180	2350 to 2610

2.3.3 - Tightening torque values for wheels

<i>Tightening torque in N.M</i>	
<i>Steering wheel nut</i>	<i>Drive wheel nut</i>
320	320

2.3.4 - Tightening torque values for hydraulic hoses

<i>Description</i>	<i>Torque to apply (Nm)</i>	<i>Spanner to use</i>
turning equal elbow JIC37 90 (10)	35	19
turning equal elbow JIC37 90 (12)	60	
turning equal elbow JIC37 90 (18)	120	32
turning equal elbow JIC37 90 (25)	155	38
nut F JIC37 (25)	155	41
nut FJIC37 (12)	60	
nut FJIC37 (18)	120	22
hose SP 1663 lgth 0.830	60	
hose SP 1663 lgth 1.100	60	
hose SP 1663 lgth 2.100	60	
hose SP 1707 lgth 2.150	15	
hose SP 1756 lgth 8.400	35	
hose SP 5025 lgth 1.680	120	32
hose SP 5113 lgth 1.700	120	32
hose SP 5113 lgth 1.800	120	32
hose SP 5113 lgth 2.170	120	32
hose SP 5113 lgth 2.230	120	32
hose SP 5238 lgth 1.900	35	
hose SP 5261 lgth 1.320	35	
hose SP 5261 lgth 1.800	35	
hose SP 5273 lgth 0.900	120	32
hose SP 5273 lgth 1.460	120	32
hose SP 5293 lgth 0.950	120	32
hose SP 791 lgth 1.170	120	32
hose SP 791 lgth 0.510	120	32
hose SP 791 lgth 0.690	120	32
hose SP 791 lgth 0.720	120	32
hose SP 791 lgth 1.020	120	32
hose SP 791 lgth 1.730	120	32
equal turning T MFM JIC37 (6)	15	
inverted turning T MMF JIC37 (10)	35	19
inverted turning T MMF JIC37 (12)	60	22
inverted turning T MMF JIC37 (18)	120	32
inverted turning T MMF JIC37 (25)	155	38
union MJIC 37 (10) M1/2" BSPP	90	27
union MJIC 37 (10) M1/4" BSPP	35	19
union MJIC 37 (12) M1/2" BSPP	90	27
union MJIC 37 (12) M1/4" BSPP	35	
union MJIC 37 (18) M1/2" BSPP	90	27
union MJIC 37 (18) M3/4" BSPP	180	36
union MJIC 37 (25) M1" BSPP	310	41
union MJIC 37 (6) M1/4" BSPP	35	19

2.3.5 - Pressure values (in bar)

- Pump:
 - flow cancellation: 240 b
 - load sensing, standby pressure: 30b

- PVG Danfoss distributor:
 - entry pressure protection: 270 b
 - rotation pressure limiter: 100 b

- Telescoping:
 - output pressure: 100 b
 - large chamber braking valve: 210 b
 - small chamber braking valve: 210 b

- Lifting:
 - lowering pressure: 100 b
 - large chamber braking valve: 210 b

- Compensation:
 - up/down braking valve: 210 b

- Jib:
 - large chamber braking valve: 210 b

- Emergency unit: 130 b

2.3.6 - Adjustment time

<i>Movement</i>	<i>Control</i>	<i>Movement duration</i>
HS deceleration	From the basket	1,30m +/- 20cm
HS travel forward and reverse	From the basket	70s / 100m
Micro speed travel forward and reverse	From the basket	22s +/- 2s / 5m
Boom lifting / lowering	From the basket	60s +/- 2s
Telescope out/in	From the basket	30s +/- 2s
Rotation left/right	From the basket	60s +/- 2s per 1/2 turn
Boom lifting / lowering	From the turntable	60s +/- 2s
Telescope out/in	From the turntable	30s +/- 2s
Rotation left/right	From the turntable	60s per 1/2 turn

3 - SAFETY SYSTEM

3.1 - FUNCTION OF RELAYS AND FUSES IN TURNTABLE BOX

(see wiring diagram)

<i>Ref.</i>	<i>Description</i>
KA2	Thermal motor start
KP1	Thermal motor stop
KT2	Motor speed acceleration (electromotor)
KMG	Main supply
KM4	Electropump contactor
FU01-10 A	Motor stop circuit fuse
FU03-80 A	Accelerator circuit fuse
FU04-30 A	Main circuit fuse
FU05-3 A	Turntable movement control circuit fuse
FU06-3 A	Platform movement control circuit fuse
FU07-20 A	Electrovalve supply circuit fuse
FU08-5 A	Turntable/platform control circuit fuse
FU09-20 A	Accessory circuit fuse
FU10-3 A	Circuit fuse
FU11-250 A	Emergency pump fuse

3.2 - FUNCTION OF SAFETY CONTACTS

(see wiring diagram)

<i>Ref.</i>	<i>Description</i>
B1	Air filter contact. Motor cut off if air filter clogged
B3	Oil pressure contact. Motor cut off if pressure insufficient
B4	Hydraulic oil temperature contact. Audible alert if temperature too high
SB1	Palm button emergency stop (turntable)
SB2	Palm button emergency stop (platform)
SQ1	Tilt sensor
SQ2	Jib (jib detection if $> 0^\circ$)
SQ3	Detection if boom lowered
SQ7	Reach limitation (motor cut off if SQ10 defective)
SQ8	Reach limitation (motor cut off if SQ11 defective)
SQ9	Boom out detection
SQ10	Reach limitation (disables telescope out movement)
SQ11	Range limitation (disables movement if boom angle less than angle defined in § 3.3.)

3.3 - POSITIONS OF ELECTRIC CONTACTS

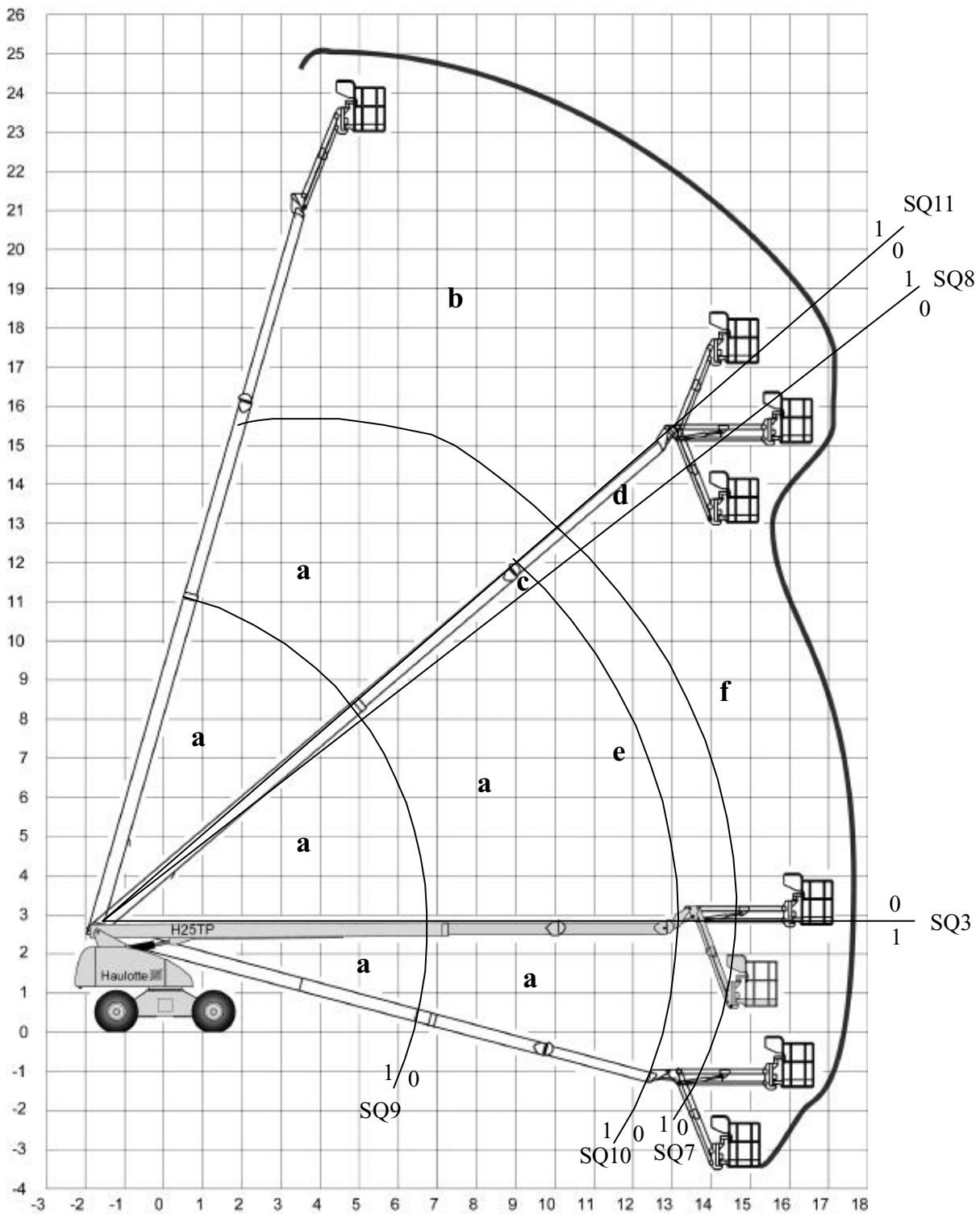

- Zone a: no break
- Zone b: movements slowed
- Zone c: telescope out disabled
- Zone d: boom lowering disabled
- Zone e: telescope out cut
- Zone f: motor cut

3.4 - OPERATING EQUATIONS

• Start

If (SB3=1 or SB4=1) and U3=0 and D+=0 and YV1 not supplied then KA2=1

If (SB3=1 or SB4=1) then module-frequency 1=1 then module-frequency 2=1 (two signals are sent at a one second interval to 698 then 699; in return, the frequency module sends 12V to 485 if the motor is running).

• Motor stop

If KA2=1 or (no motor fault for more than 6 seconds)* and SQ14=1 then KP1=1

*No motor fault => D+=1 and B3=1

• Accelerator

If (HM4=1 or HM31=1 or HM2=1) or SA2=1 then KT2=1

The accelerator is time delayed for 0.5 seconds.

• Compensation

- Up

If SA5a=1 and SM31ab=0 and SM2ab=0 then YV15a=1 and YV2b=1 and YV1=1

- Down

If SA5b=1 and SM1ab=0 and SM2ab=0 then YV15b=1 and YV2b=1 and YV1=1

• Rotation

- Right

If SA4a=1 then YV24=1 and YV19b=1 and YV2b=1 and YV1=1

- Left

If SA4b=1 then YV24=1 and YV19a=1 and YV2b=1 and YV1=1

• Jib

- Up

If (SA6b=1 or SA7b=1) then YV18b=1 and YV2a=1 and YV1=1

- Down

If (SA6a=1 or SA7a=1) then YV18a=1 and YV2a=1 and YV1=1

• Rotation

- Turntable

1°Left

If SA15a=1 then YV1=1 and YV5=1

2°Right

If SA15b=1 then YV1=1 and YV5=1

- Platform

1°Left

If HM31=1 and SM31ab=0 followed by SM31ab=1 then YV1=1 and YV5=1

2°Right

If HM31=1 and SM31ab=0 followed by SM31ab=1 then YV1=1 and YV5=1

• Lifting

- Turntable

1°Up

If SA13a=1 and SQ9=1 then YV1=1 and YV3=1

2°Down

If SA13b=1 and SQ9=1 then YV1=1 and YV3=1

- Platform

1°Up

If HM31=1 and SM1ab=0 followed by SM1ab=1 and SQ9=1 then YV1=1 and YV3=1

2°Down

If HM31=1 and SM1ab=0 followed by SM1ab=1 and SQ9=1 then YV1=1 and YV3=1

• Telescoping

- Turntable

1°Out
 If SA8a=1 then YV1=1 and YV4=1
 2°Down
 If SA8b=1 then YV1=1 and YV4=1
 - Platform
 1°Out
 If HM2=1 and SM2ab=0 followed by SM2ab=1 then YV1=1 and YV4=1
 2°In
 If HM2=1 and SM2ab=0 followed by SM2ab=1 then YV1=1 and YV4=1
 • Travel
 If machine extended then MicroSpeed=1
 If machine folded then MicroSpeed=0
 If SA11a=0 and SA11b=1 and MicroSpeed=0 then LowSpeed=1(YV1=1
 If SA11a=0 and SA11b=0 and MicroSpeed =0 then MediumSpeed=1(
 YV1=1 and YV12=1 and YV10=1
 If SA11a=1 and SA11b=0 and MicroSpeed =0 then HighSpeed=1(YV1=1
 and YV12=1 and YV10=1 and YV8=1
 If HM4=1 and SM4ab=0 followed by SM4ab=1 and SA9a=0 and SA9b=0
 and SM31ab=0 and SM2ab=0 then YV6=1 and YV7=1
 LowSpeed, MediumSpeed, HighSpeed: full setpoint
 MicroSpeed: low setpoint
 • Steering
 - Rear axle
 1°Left
 If SM4c=1 then YV16a=1 and YV2b=1 and YV1=1
 2°Right
 If SM4d=1 then YV16b=1 and YV2b=1 and YV1=1
 • Differential blocking
 If SA3=1 and SA11a=0 and MicroSpeed=0 then YV9=1 and YV13=1
 • Buzzer and horn
 If SB5=1 then HA1=1
 If SQ1=0 and machine extended, then the buzzer sounds continuously.
 If B4=0 then the buzzer sounds at frequency F1.
 If option_Travel_buzzer=1 and HM4=1 then the buzzer sounds at frequency F2.
 • Light indicators
 If B1=0 then HL2=1
 If B3=0 then HL4=1
 • Other functions: Overload, Fail-safe, Tilt
 - Fail-safe
 During movements, the fail-safes can be released for 0.5s.
 If the fail-safe is maintained for x seconds (manipulator in neutral), the movement cannot be made.
 Travel: x = 6s
 Movements: x=4s
 - Tilt
 When the machine is extended and tilted, the buzzer sounds continuously.

4 - WIRING DIAGRAMS

4.1 - DIAGRAM E 455 - FOLIO 01/05

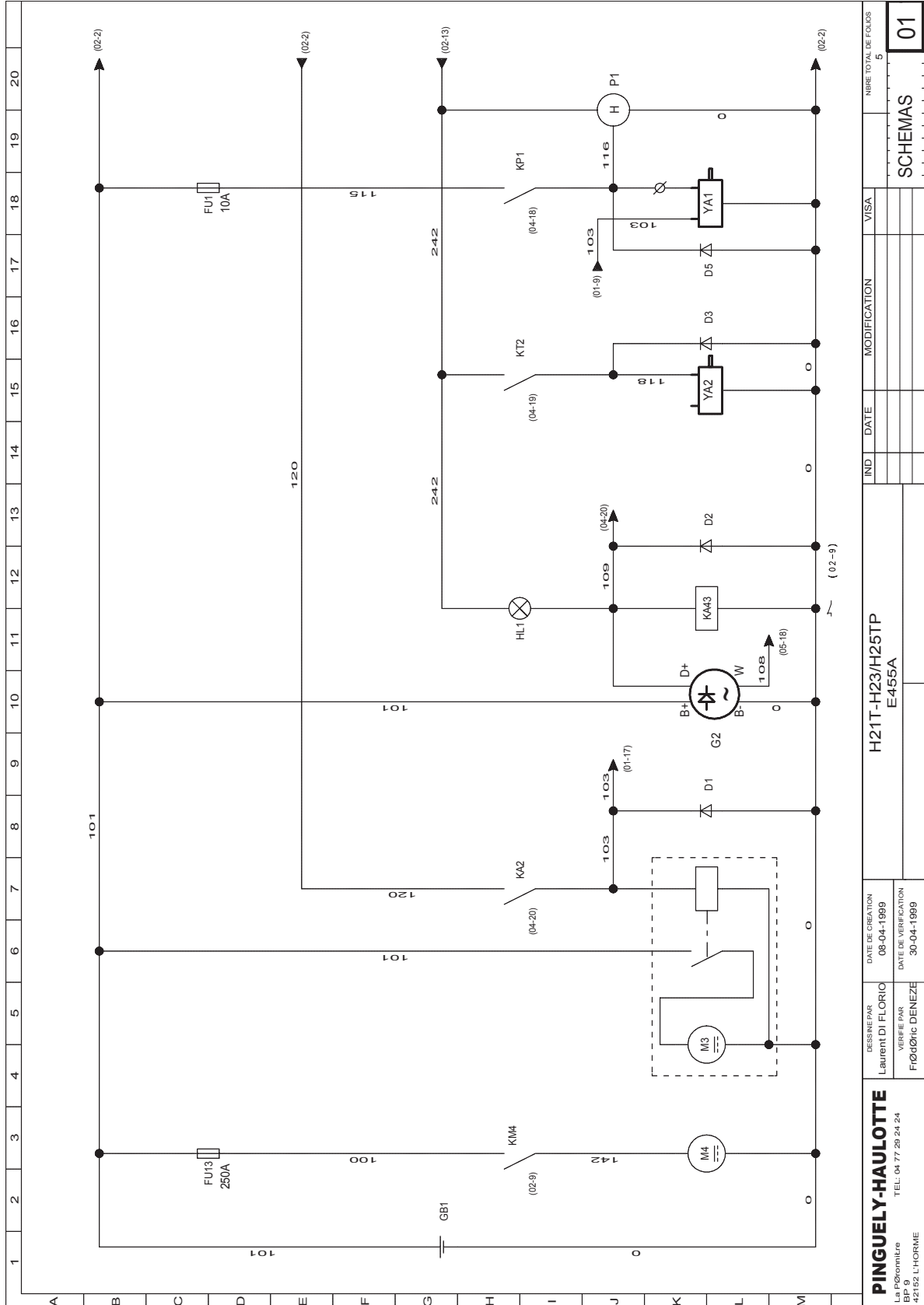

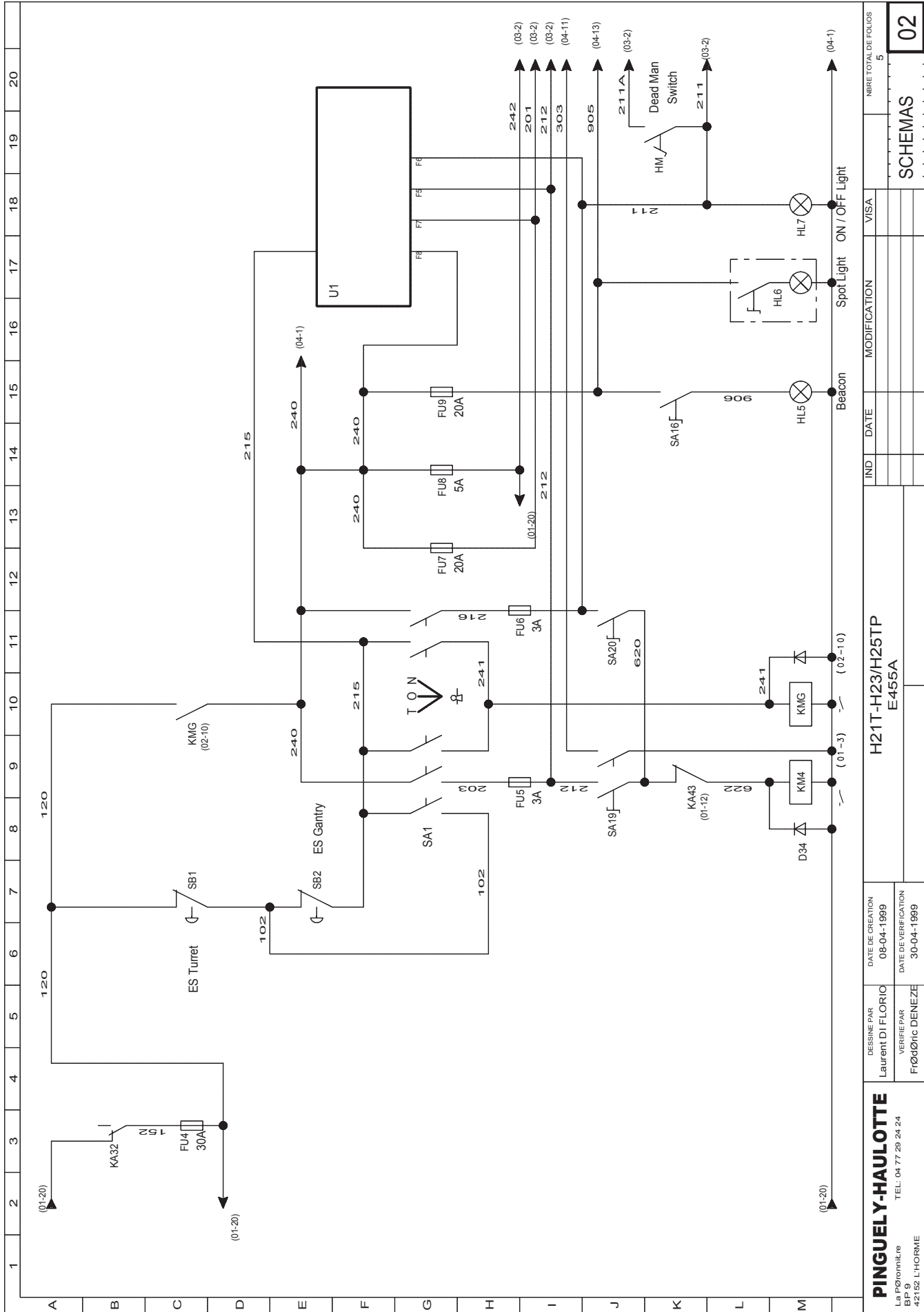

PINGUELY-HAULOTTE La Pinguely BP 9 421152 L'HORME		DESIGNÉ PAR Laurent DI FLORIO	DATE DE CREATION 08-04-1999	H21T-H23/H25TP E455A		IND	DATE	MODIFICATION	VISA	NBR TOTAL DE FOLIOS 5	
		VERIFIEE PAR Floric DENIZE	DATE DE VERIFICATION 30-04-1999							SCHEMAS 02	

FOLIO 03/05

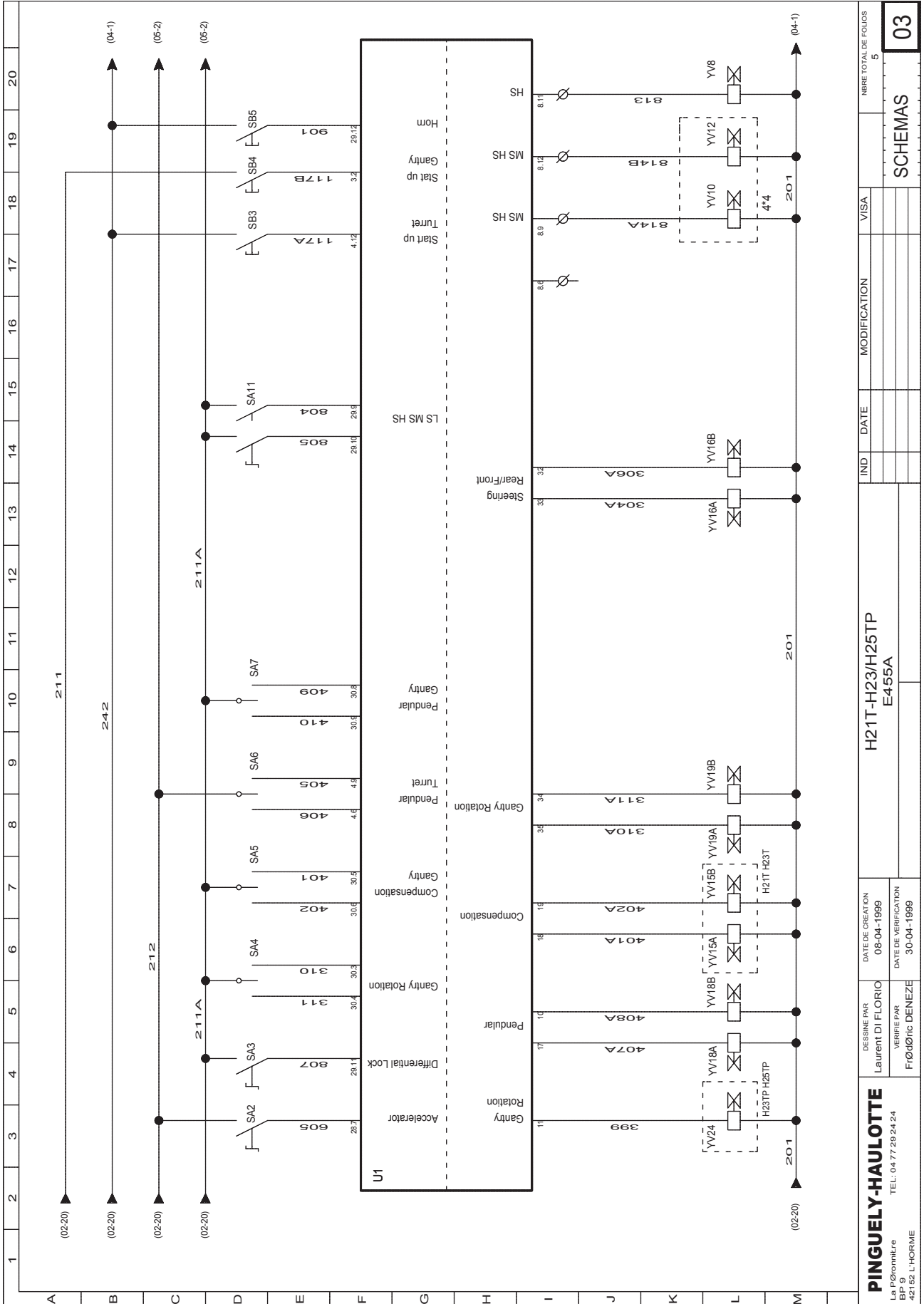

PINGUELY-HAULOTTE La Pinguely BP 9 42152 L'HORME		DESSINE PAR Laurent DI FLORIO	DATE DE CREATION 08-04-1999	H21T-H23/H25TP E4-55A		IND	DATE	MODIFICATION	VISA	NBRE TOTAL DE FOLIOS 5
		VERIFIE PAR FRODORIC DENEZE	DATE DE VERIFICATION 30-04-1999							

03

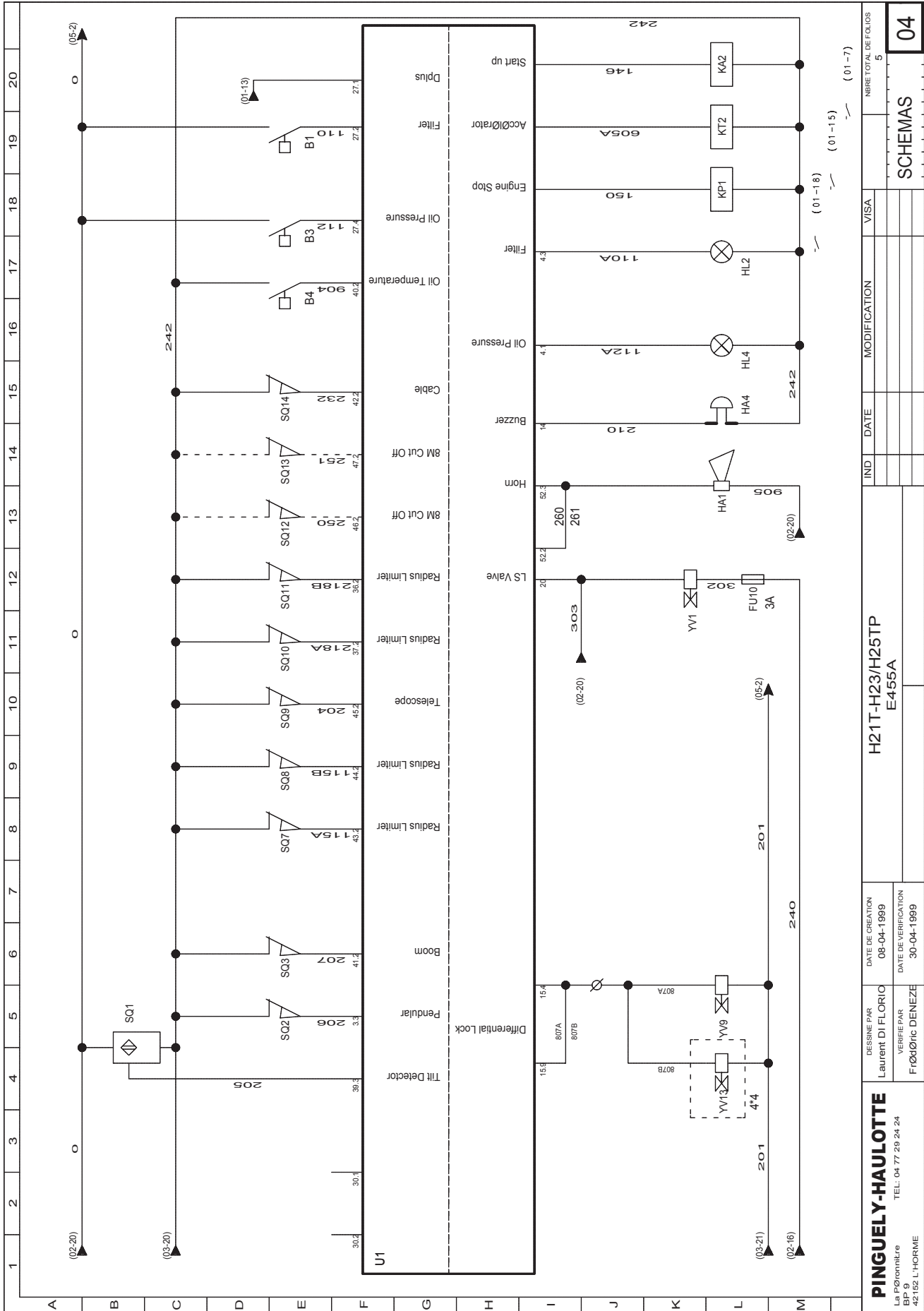

PINGUELY-HAULOTTE L.P. Pinguely BP 30 42192 L'HORME		DESSINE PAR Laurent DI FLORIO	DATE DE CREATION 08-04-1999	H21T-H23/H25TP E455A		IND	DATE	MODIFICATION	VISA	INDRE TOTAL DE FOLIOS 5
		VERIFIE PAR FLOÛRIC DENEZE	DATE DE VERIFICATION 30-04-1999							04
										SCHEMAS

FOLIO 05/05

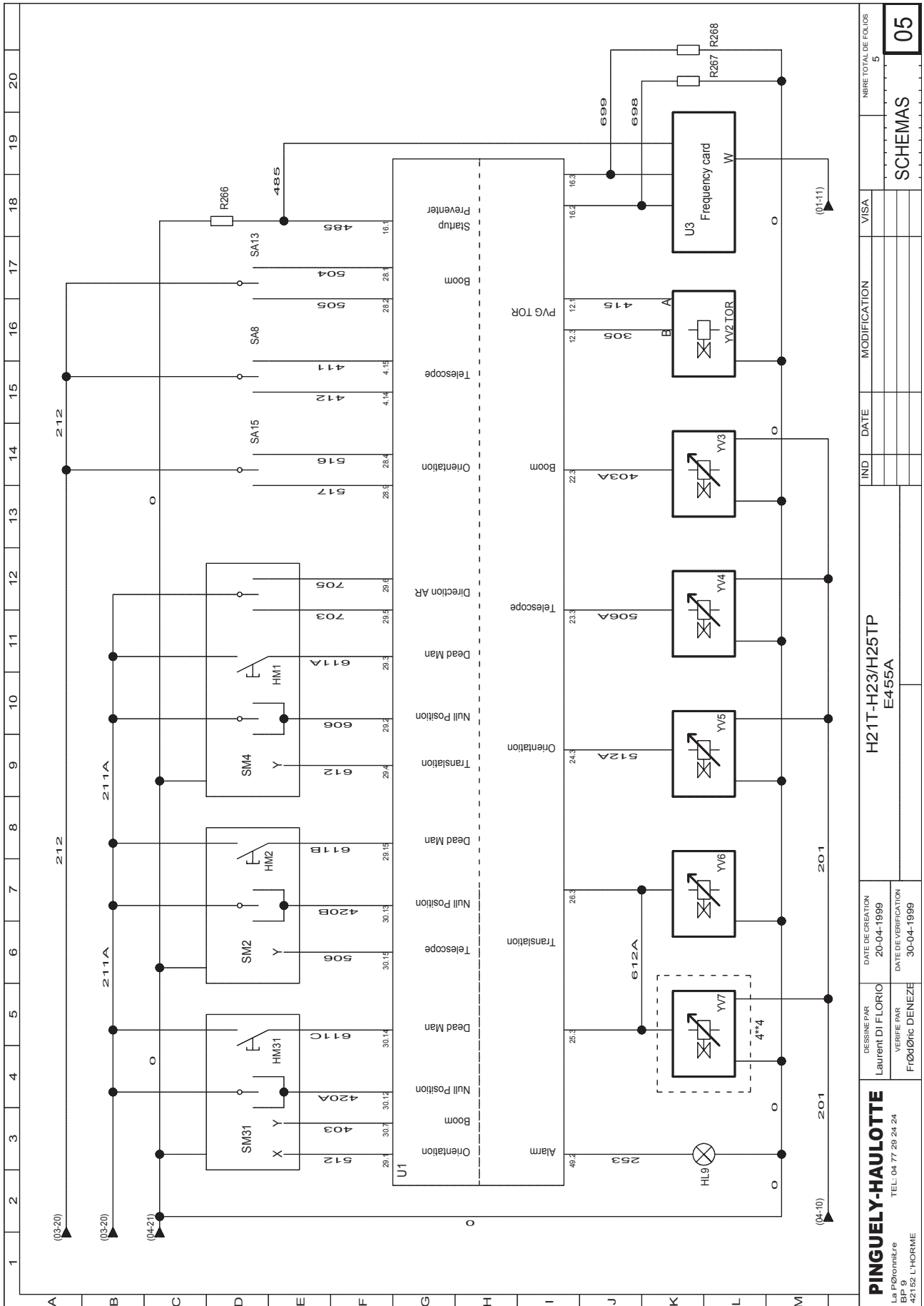

PINGUELY-HAULOTTE La Pinguinière BP 9 42162 L'HORME		DATE DE CREATION 20-04-1999	DATE DE VERIFICATION 30-04-1999	H21T-H23/H25TP E455A		IND	DATE	MODIFICATION	VISA	NBRE TOTAL DE FOLIOS 5	05
SCHEMAS											

4.2 - POSITIONS OF ELECTRIC COMPONENTS ON THE MOTHER BOARD

4.2.1 - Description

SCREW			Connector		
1	101	+ Battery	28	1	Flashing light
2	105	+ Bi-energy machine - option	29	2	Bottom box door
3	120	+ Main	30	3	Top control panel
4	103	Starter	31	4	Bottom box door
5	118	Accelerator control	32	55	KMG main relay
6	240	Main supply after contactor	33	5	Emergency pump KM4 contactor
7	102	Emergency stop circuit	34	6	Connector for console
8	215	Emergency stop circuit	35	52	Horn HA1
9	0	- Battery	36	7	Gas electrovalves - option
10	226	Gas/petrol machine - option	37	54	Proportional valve output
11	224	Gas/petrol machine - option	38	14	Buzzer
RELAY			39	47	SQ13
12	KA2	Starter	40	22	Boom lifting PVG
13	KP1	Motor stop	41	23	Telescoping or arm lifting PVG
14	KA32	Electric / thermal power switching	42	24	Rotation PVG
15	KT2	Accelerator	43	25	Travel PVG
16	KA43	Emergency pump safety	44	26	Travel PVG
17	KA37	Converter for bi-energy machine	45	27	Motor wiring harness
18	KA46	Petrol / gas switching	46	28	Top control panel
FUSE			47	29	Top control panel
19	F1	Motor stop	48	30	Top control panel
20	F3	Maintain acceleration	49	36	SQ11
21	F4	Main	50	37	SQ10
22	F5	+ Low position	51	39	SQ6 Tilt
23	F6	+ High position	52	40	Hydraulic tank temperature probe B4
24	F7	+ Electrovalve	53	41	SQ3
25	F8	+ Permanent (sensor supply)	54	42	SQ4 or SQ14
26	F9	+ Accessories	55	43	SQ7
27	F10	+ Load Sensing valve for machine with PVG	56	44	SQ8
			57	45	SQ9

4.2.2 - Positions of screws, connectors and relays

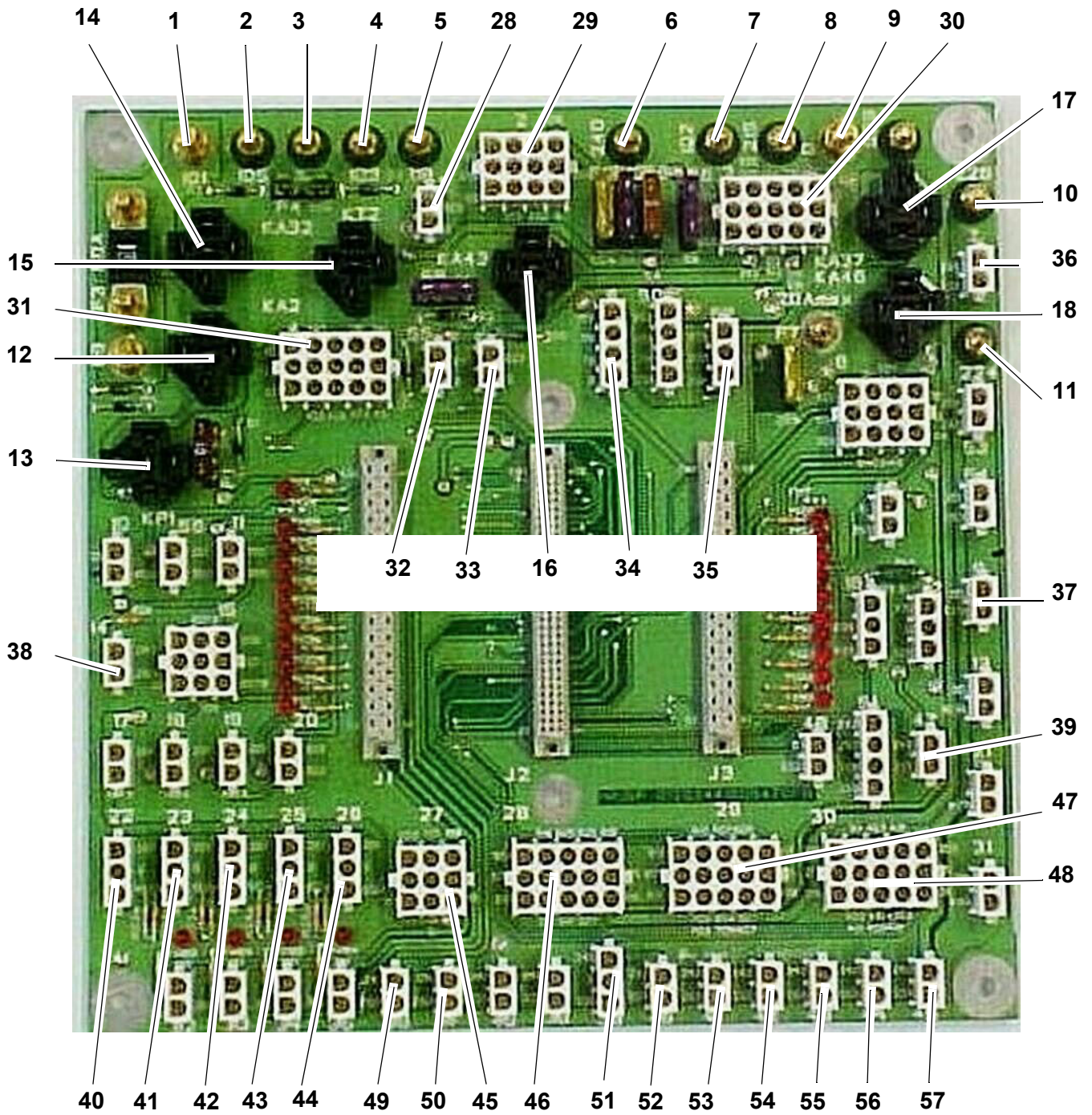

4.2.3 - Positions of fuses

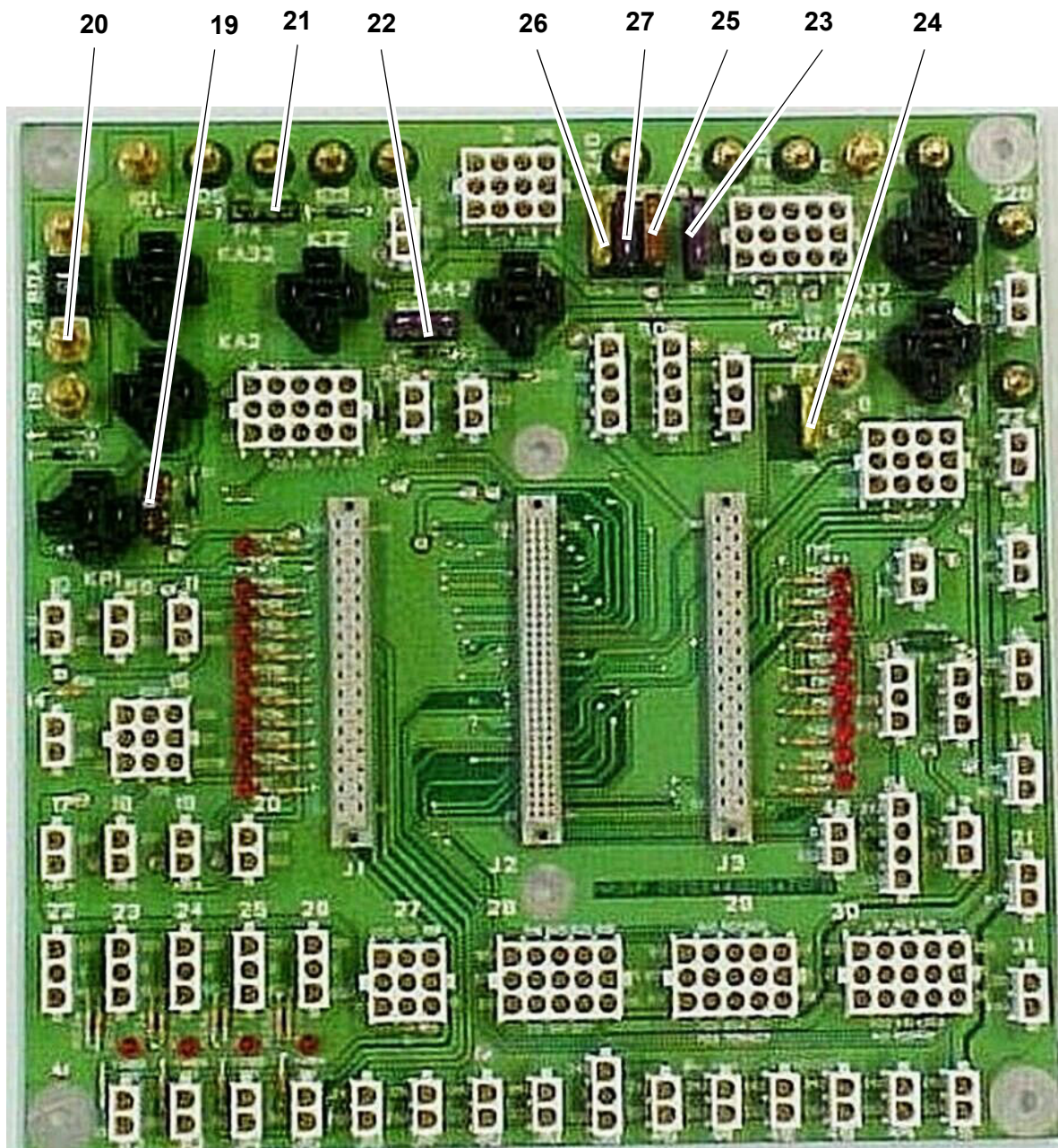

4.2.4 - Positions of diagnosis help LEDs

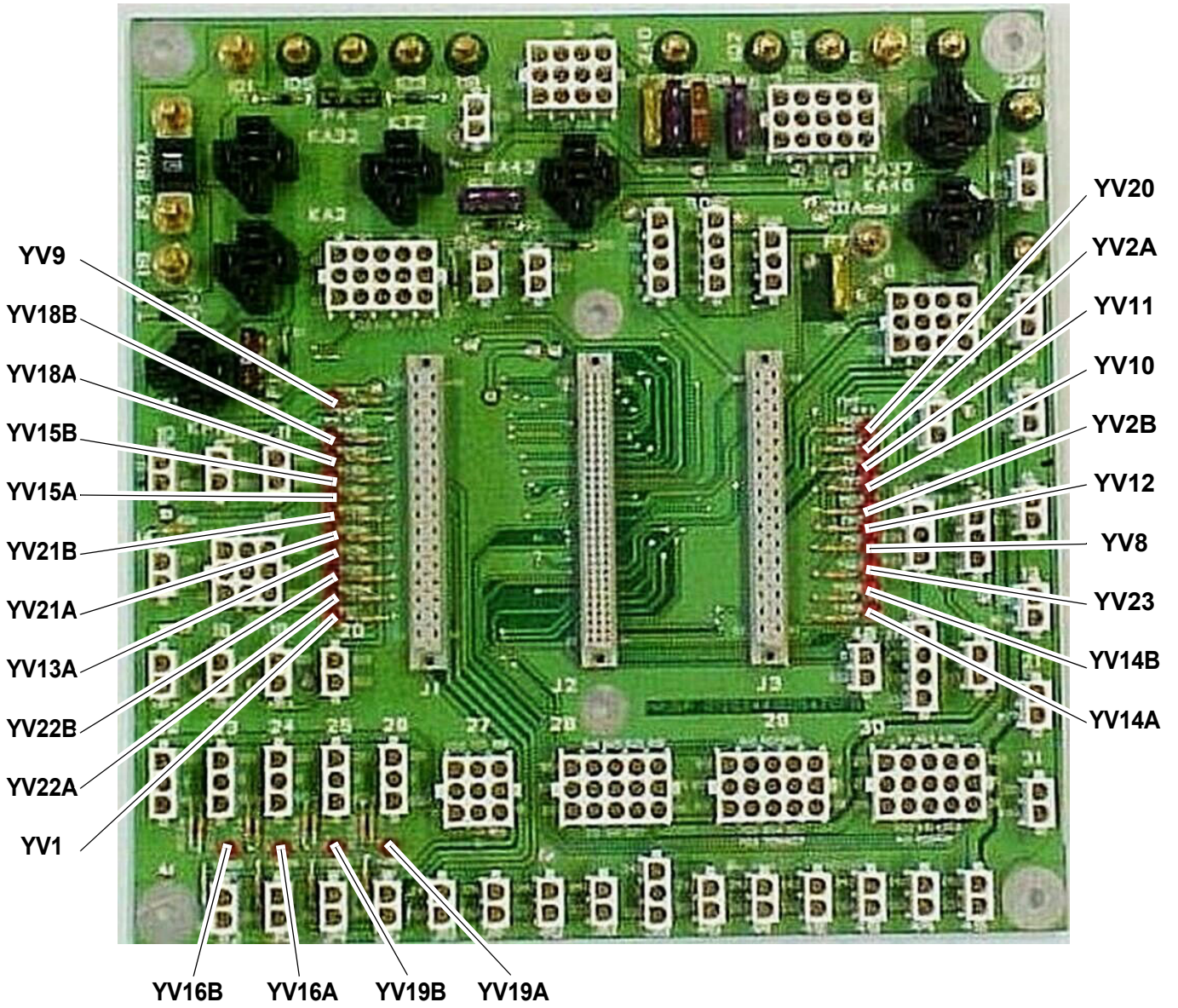

5 - HYDRAULIC DIAGRAMS

5.1 - DIAGRAM H21T / H23T REFERENCE B15714

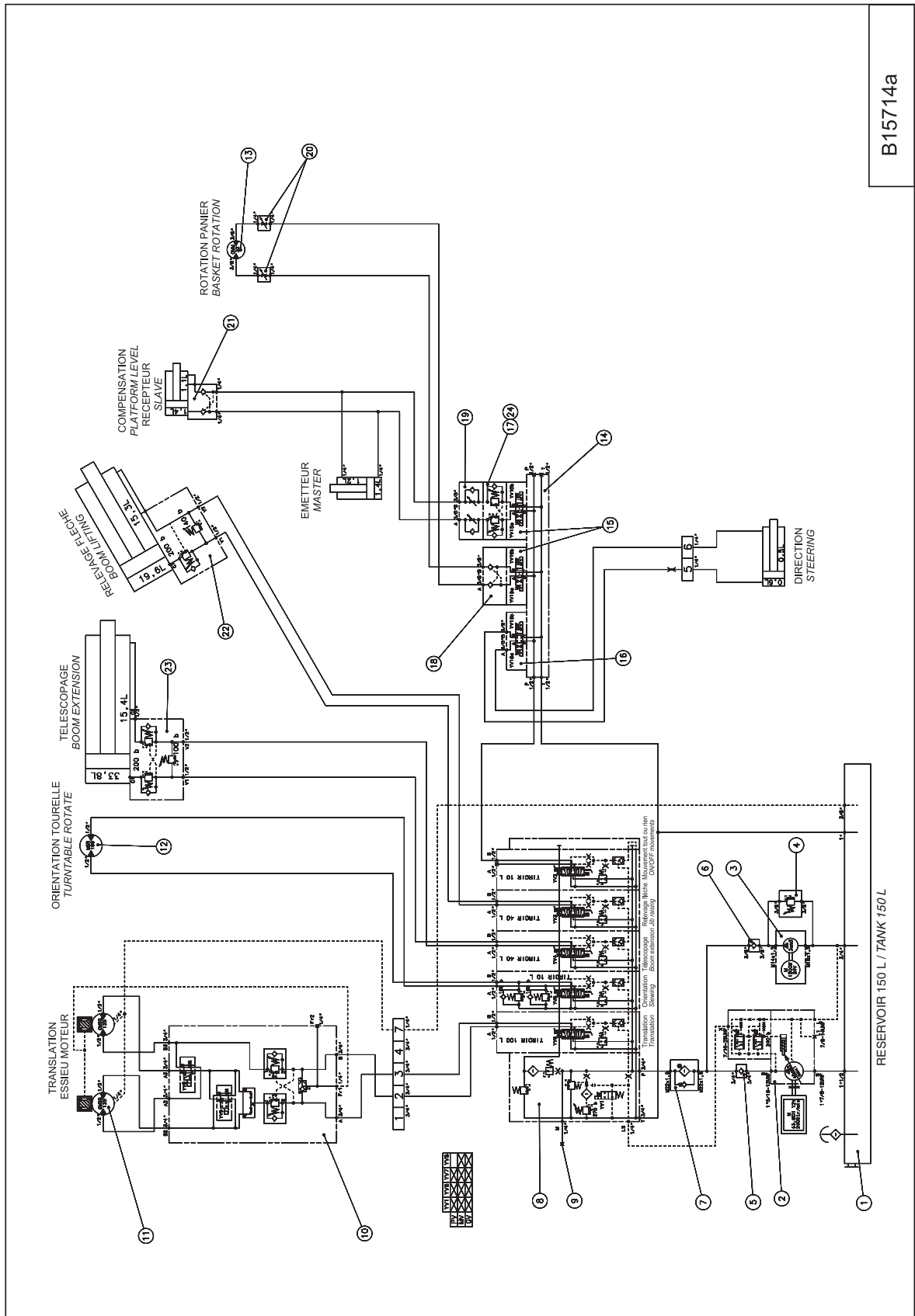

B15714a

5.2 - DIAGRAM H21TX / H23TX REFERENCE B15713

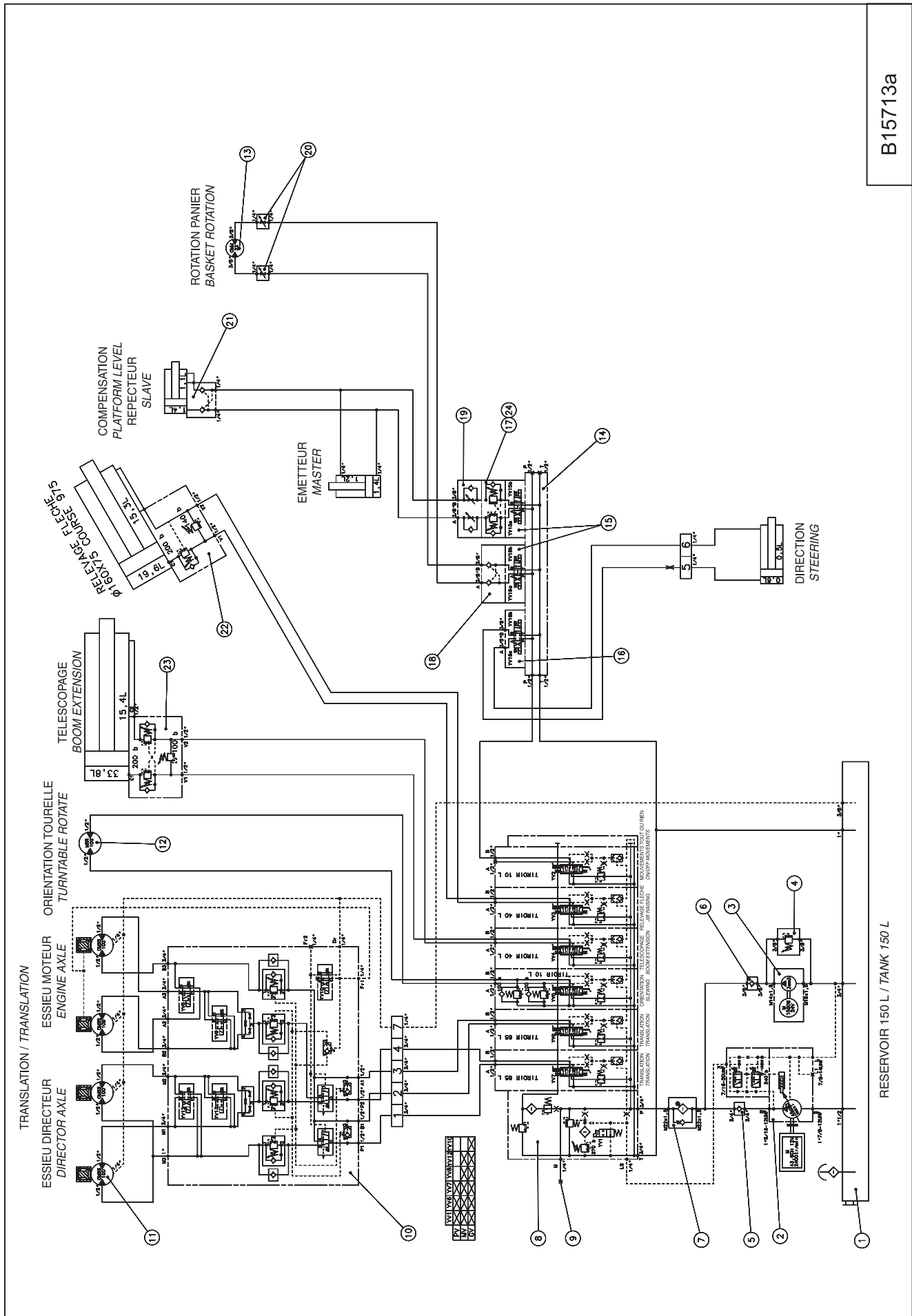

B15713a

5.5 - FUNCTIONS OF ELECTROVALVES

5.5.1 - "On/off" electrovalves

12v = electro controlled / 0v = electro not controlled

YV1	Load Sensing 303, time delayed for 2 seconds
YV2a	Jib305
YV2b	Compensation, rotation, steering 415
YV8	High speed vitesse 813
YV9	Differential blocking 807A
YV10	MediumSpeed HighSpeed 814A
YV12	MediumSpeed HighSpeed 814B
YV13	Differential blocking 807B
YV19a	Compensation up 401A + basket rotation L
YV19b	Compensation down 402A + basket rotation R
YV16a	Left REAR steering in 4*4 304A
YV16b	Right REAR steering in 4*4 306A
YV18a	Jib down 407A
YV18b	Jib up 408A
YV24	Basket rotation 399

5.5.2 - Proportional electrovalves

Supply voltage of proportional electrovalves varies from 6v to 3v in one direction and from 6v to 9v in the other.

YV3	Lifting403A
YV4	Telescoping 506A
YV5	Rotation 512A
YV6	Travel 612A
YV7	Travel 612A

6 - MAINTENANCE

6.1 - GENERAL RECOMMENDATIONS

The maintenance operations described in this manual apply when the machine is used in ordinary conditions.

Under difficult conditions: extreme temperatures, high humidity, a polluted atmosphere, high altitude, etc., some of these operations should be carried out more frequently and special precautions should be taken: for more details check the motor manufacturer's manual and consult your local PINGUELY-HAULOTTE agent.

Only qualified and competent personnel may carry out interventions on the machine and safety instructions relating to personnel and environment protection must be respected.

As far as the motor is concerned, refer to the manufacturer's manual and instructions.



Caution!

- Do not use the machine as a welding earth.**
- Do not weld without disconnecting the (-) then (+) terminals of the batteries.**
- Do not use to jumpstart other vehicles.**

Regularly check proper operation of the safety mechanisms:

- Tilt: buzzer
- Passage to microspeed when the machine is extended.

6.2 - SPECIFIC RECOMMENDATIONS

Before any maintenance intervention on the elevating platform, indicate on the turntable and platform control panels that the machine is being serviced. If possible, restrict access to the elevating platform to intervention personnel only.

6.2.1 - Specific tools

Personnel should therefore be familiar with the use of the specific tools used (measurement device, torque tightening device, lifting apparatus, etc.) and respect the operating limits specified in the documentation that is supplied with the tools.

Incorrect use of a tool (incorrect adjustment after a reading error) may lead to premature deterioration of the elevating platform (or more seriously, an accident), for which PINGUELY-HAULOTTE cannot be held responsible.

6.2.2 - Replacing an element

Before replacing an element, the machine must be put in the maintenance configuration (see Chapitre 6.3, page 38) and the electric power supply cut off (see Chapitre 6.4, page 38).

All distributing valves are "with open centre": breaking the electric circuit therefore decreases pressure in the hydraulic circuits, up to the non-return valves flanged on the cylinders. An element can be replaced safely if the procedures described in the maintenance sheets are respected (unscrew hydraulic connectors slowly to release residual pressure).

To preserve the integrity of the safety systems and the technical characteristics of the elevating platform, it is essential to use original parts and to respect the initial setting and tightening torque values (see Chapitre 2, page 7).

6.2.3 - Locating the breakdown

Certain checks require the elevating platform to be switched on. In this case, personnel must ensure:

- that the measurement devices used are properly insulated,
- that they do not touch the live parts,
- that they are not wearing or carrying metal objects that may deteriorate the live components (e.g.: dropping a spanner during an intervention on the batteries).

6.2.4 - Environment protection

To protect the environment, an oil collection tank must be used during interventions requiring hydraulic oil change or where there may be a hydraulic leak.

6.3 - MAINTENANCE SYSTEM

Photo 1

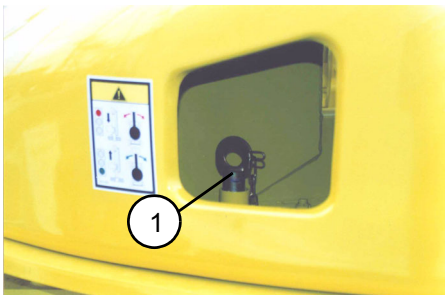

Instructions:

Maintenance configuration:

- Position the elevating platform on a firm, horizontal surface.
- If possible, fold the machine completely. Otherwise, for specific operations, put the various components into slings.
- Put the turntable rotation blocking pin into place (ref 1, Photo 1, page 38).

Restoring operational configuration:

- Remove the blocking pin (ref. 1, Photo 1, page 38).

6.4 - ELECTRIC POWER SUPPLY

Photo 2

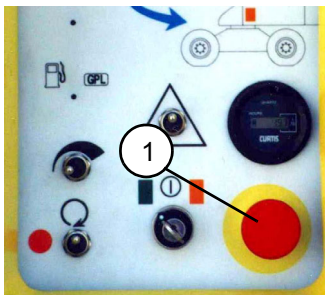

Instructions:

Cutting off the electric power supply:

Press the turntable emergency stop (ref. 1, Photo 2, page 38).

Restoring the electric power supply:







Reset the emergency stop (ref. 1, Photo 2, page 38).

6.5 - MAINTENANCE PLAN

The plan shows the frequency, area of maintenance (device) and the consumables to be used.

The reference shown in the symbol shows the area maintained based on the frequency.

The symbol represents the consumable to use (or the operation to be carried out).

Consumable	Specification	Symbol	Lubricants used by Pinguely-Haulotte	ELF	TOTAL
Motor oil	SAE 15W40		SHELL RIMULA-X		
Gearbox oil	SAE 90		SHELL SPIRAXA EP 80 W 90	Tranself EP 80 W 90	TM 80 W/90
Hydraulic oil	AFNOR 48602 ISO VG 46		SHELL TELLUS T 46	HYDRELF DS 46	EQUIVIS ZS 46
Biodegradable hydraulic oil (option)	HF-E46		SHELL Naturelle HF-E46		
Lithium grease	KP 2 K		ESSO Beacon EP2	Epaxa 2	
Leadfree grease	Grade 2 or 3		ESSO GP GREASE	Multimotive 2	Multis EP 2
Exchange or specific operation					

HOURS

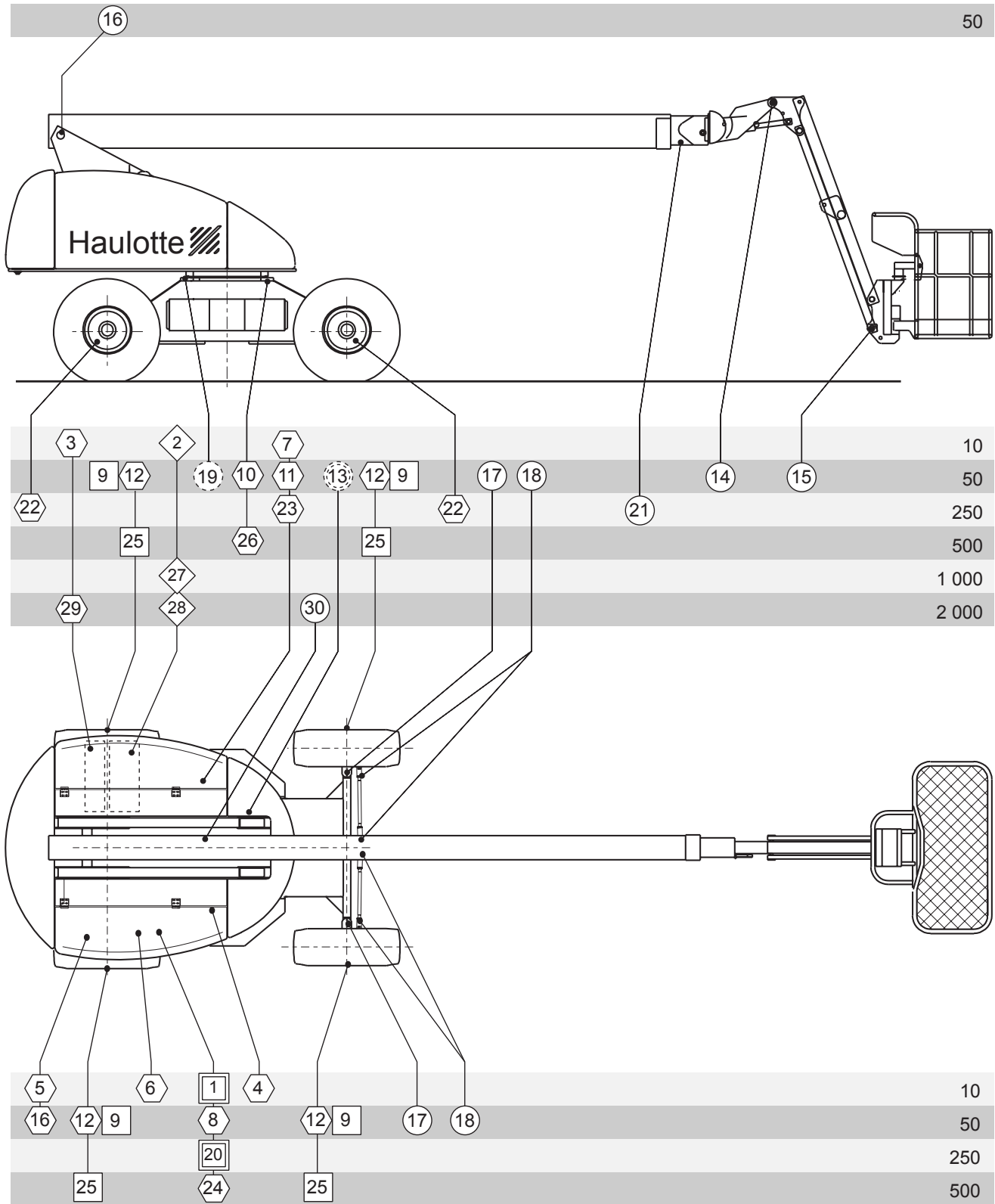

6.6 - OPERATIONS**6.6.1 - Summary table.**

<i>Frequency</i>	<i>Ref.</i>	<i>Operation</i>
Every day or before each use		Test: <ul style="list-style-type: none"> • the horn • the tilt detector and safety systems
	1	Check the levels: <ul style="list-style-type: none"> • motor oil
	2	<ul style="list-style-type: none"> • hydraulic oil (see fiche P008)
	3	<ul style="list-style-type: none"> • diesel
	4	<ul style="list-style-type: none"> • electric batteries
	5	Check the cleanliness: <ul style="list-style-type: none"> • diesel prefilter, replace if water or impurities are found
	6	<ul style="list-style-type: none"> • motor air filter • machine (in particular, check the tightness of the connectors and hoses. Use this opportunity to check the condition of the tyres, wires and all accessories and equipment).
	7	Check clogging of the hydraulic oil filter. Change the cartridge if the clogging indicator is visible (see sheet P009). Check the degree of wear of the articulation pins.
After the first 50 hours	8	Change the hydraulic filter cartridge (see sheet P009) (see 250 hours frequency)
	9	Change the oil of the drive wheels (see sheet P007) (see 500 hours frequency) (2 points for model 4x2 - 4 points for model 4x4)
	10	Check the tightness of the slew ring screws (torque 27 daN.m)
Every 50 hours	11	Motor: see Manufacturer's manual
	12	Check the level of the drive wheel reducing gears (see sheet P007)
		Lubricate:
	14	<ul style="list-style-type: none"> • jib articulation pin (for H23TP and H25TP): 2 points
	15	<ul style="list-style-type: none"> • basket link part articulation pin: 4 points
	16	<ul style="list-style-type: none"> • boom bottom pin: 1 point
	17	<ul style="list-style-type: none"> • wheel pivot pins: 8 points
18	<ul style="list-style-type: none"> • steering axle, central pivot and clevis pin: 10 points 	
19	<ul style="list-style-type: none"> • slew ring: bearing 2 points 	
Every 250 hours		Test the emergency electropump unit: make a boom movement using the emergency electropump unit.
	20	Motor: see Manufacturer's manual
	21	Lubricate the friction parts of the telescope (spatula). Use this opportunity to check the condition of the friction pads.
	21	Lubricate the telescoping cable.
	22	Check the tightness of the wheel nuts (torque 32 daN.m)
	23	Change the hydraulic filter cartridge (see sheet P009)
Every 500 hours	24	Motor: see Manufacturer's manual
	25	Change the oil of the wheel reducing gears (see sheet P007). Fill up (capacity 4 x 1.4 litres.)
	26	Slew ring screws: check tightness and tighten if necessary (torque 27 daN.m)
OPTION: every 500 hours or every 6 months	27	Change the oil of the hydraulic oil tank (if using biodegradable oil)
Every 1000 hours or every year		Motor: see Manufacturer's manual
	27	Change the oil of the hydraulic tank Check the tension of the telescope cables.

<i>Frequency</i>	<i>Ref.</i>	<i>Operation</i>
Every 2000 hours	28	Change the oil of the hydraulic tank and whole circuit
	29	Empty and clean the diesel tank
	30	Lubricate the rotation reducing gear: 1 point
Every 3000 hours		Check the condition of the safety cable, the telescoping cables and friction pads and the electric wires and hydraulic hoses.

REMINDER: The above frequencies should be reduced if work is carried out in difficult conditions (consult After Sales Service if necessary).

6.7 - PRESENCE OF LABELS

Make sure that the labels and plates informing personnel of the various dangers related to machine use are in good condition.

The labels informing operators on the use and maintenance of the machine must also be in good condition.

An illegible label may result in incorrect or dangerous use of the machine.

Instructions:

Check that the labels are present:

Check that all the labels described below are legible and in place. Replace them if necessary (additional copies can be supplied on request, if necessary).

6.7.1 - "Yellow" labels

6.7.2 - "Orange" labels

2

CONSIGNE D'UTILISATION
POUR UTILISER CET APPAREIL
L'OPERATEUR DOIT

- 1 - Lire et comprendre les informations contenues dans le manuel de conduite et les inscriptions apposées sur la machine, se familiariser avec les commandes,
- 2 - Etre formé et entraîné pour la conduite de celui-ci, sous la responsabilité de son employeur.
- 3 - Assurer correctement l'entretien suivant le catalogue constructeur.
- 4 - Ne pas utiliser l'appareil en cas de dysfonctionnement.
- 5 - Ne pas laver sous pression les composants électriques.
- 6 - Ne rien démonter, la stabilité serait modifiée.
- 7 - Ne pas modifier l'appareil sans accord du constructeur.
- 8 - Ne pas utiliser la machine comme masse de soudure.
- 9 - Ne pas souder sur la machine sans déconnecter les cosses des batteries, se référer à la notice de conduite et d'entretien.

INSPECTION JOURNALIERE

- 1 - Vérifier le niveau d'huile hydraulique et le liquide des batteries.
- 2 - Vérifier s'il n'y a pas de signe apparent de détériorité (fuite hydraulique, bouillonnante, liaisons électriques).
- 3 - Vérifier le fonctionnement de l'indicateur de devers en faisant fonctionner l'alarme sonore.

INSTRUCTION AVANT UTILISATION

- 1 - Enlever la broche de blocage d'orientation (s'il y a une tourelle).
- 2 - **IMPORTANT.** La prise doit être raccordée sur une installation électrique protégée par un disjoncteur différentiel 30 mA (NORME CIS 100)

MISE EN ROUTE

- 1 - Déverrouiller l'arrêt d'urgence, puis actionner le bouton de démarrage.
- 2 - En cas de non fonctionnement, attendre 10 s et renouveler l'opération.

INTERDICTION
D'UTILISER L'APPAREIL
PENDANT LA CHARGE DES BATTERIES

7814 342

RECOMMENDATIONS FOR USE
DEFEDE L'USO DI QUESTA MACCHINA
L'OPERATORE DEVE

1. Read and understand the information contained in the manual and the instructions printed on the machine, and become familiar with the controls.
2. Be trained and trained for the operation of this machine, under the responsibility of your employer.
3. Carry out the maintenance operations according to the manufacturer's instructions.
4. Do not use the machine in the event of a malfunction.
5. Do not clean the machine with high pressure water.
6. Do not modify the machine without the manufacturer's approval.
7. Do not use the machine as a welding point.
8. Do not weld on the machine without disconnecting the battery terminals. See the instructions in the maintenance manual.

DAILY INSPECTION

1. Check the level of hydraulic oil and battery liquid.
2. Check that there are no signs of apparent deterioration (hydraulic leaks, bubbling, electrical connections).
3. Check that the emergency stop button is working properly.

INSTRUCTIONS BEFORE USE

1. Remove the locking pin (if there is a turret).
2. **IMPORTANT.** The plug must be connected to a protected electrical installation (30 mA differential circuit).

STARTUP

1. Turn the battery safety switch to the "ON" position.
2. Release the emergency stop button and press the start button. Wait for the machine to stop before using it.

INTERDICTION D'UTILISER LA MACHINE EN CAS DE MALFONCTIONNEMENT.

7814 342

ISTRUZIONI PER L'USO
PER UTILIZZARE QUESTA MACCHINA L'OPERATORE DEVE

1. Leggere e comprendere le informazioni contenute nel manuale di istruzioni stampate sulla macchina, e familiarizzarsi con i comandi.
2. Essere formato e addestrato per l'operazione di questa macchina, sotto la responsabilità del proprio datore di lavoro.
3. Eseguire le operazioni di manutenzione secondo le istruzioni del costruttore.
4. Non utilizzare la macchina in caso di guasto.
5. Non pulire la macchina con acqua ad alta pressione.
6. Non modificare la macchina senza l'approvazione del costruttore.
7. Non utilizzare la macchina come massa di saldatura.
8. Non saldare sulla macchina senza aver sconnesse le batterie. Vedere le istruzioni nel manuale di manutenzione.

ISPEZIONE QUOTIDIANA

1. Controllare il livello dell'olio idraulico e il liquido delle batterie.
2. Controllare che non ci siano segni evidenti di deterioramento (perdite idrauliche, effervescenze, contatti elettrici).
3. Controllare che il pulsante di emergenza funzioni correttamente.

ISTRUZIONI PRIMA DELL'UTILIZZAZIONE

1. Rimuovere il fermo di bloccaggio (se presente).
2. **IMPORTANTE.** La presa deve essere collegata ad un impianto elettrico protetto da un interruttore differenziale (30 mA).

AVVIAMENTO

1. Portare l'interruttore di sicurezza a "ON" e premere il pulsante di avvio.
2. Rilasciare il pulsante di emergenza e premere il pulsante di avvio. Attendere che la macchina si fermi prima di utilizzarla.

È INTERDICTION D'UTILISER LA MACCHINA EN CAS DE MALFONCTIONNEMENT.

7814 342

GEbruKsAnwIsZInG
VOOR HET GEBRUIK VAN DE TOESTEL
MOET DE OPERATOR

1. De informatie en de bedieningsinstructies en de aanwijzingen op de machine lezen en zich vertrouwd maken met de bedieningsinstructies.
2. De machine moet en getraind zijn voor de bediening van deze machine, onder de verantwoordelijkheid van zijn werkgever.
3. Het onderhoud en de reparaties moeten volgens de instructies van de fabrikant worden uitgevoerd.
4. De machine niet gebruiken bij storingen.
5. De machine niet reinigen met hoge druk water.
6. De machine niet wijzigen zonder de fabrikant te raadplegen.
7. De machine niet gebruiken als lasmassa.
8. De machine niet solderen zonder de batterijen te ontkoppelen. Zie de handleiding voor het onderhoud en de reparatie.

DAGELIJKSE INSPECTIE

1. Het peil van de hydraulische olie en de accu's vloeistof.
2. Controleer of er geen tekenen van versleten of beschadigde onderdelen zijn.
3. Controleer of de noodstopknop goed werkt.

INSTRUCTIES VOOR HET

1. Verwijder de blokkeerpin (indien van toepassing).
2. **WICHTIG.** Het stopcontact moet worden aangesloten op een beveiligd elektrisch systeem (30 mA).

INSCHAKELING

1. De machine veiligstellen en de startknop indrukken.
2. De noodstopknop loslaten en de startknop indrukken.

HET IS VERBODEN
DE TOESTEL TE GEBRUIKEN
ALS DE ACCOU WERKT NIET GOED

7814 342

INSTRUCCIONES DE UTILIZACION
PARA UTILIZAR ESTE APARATO
EL OPERADOR DEBE

1. Leer y comprender las informaciones contenidas en el manual de instrucciones y las inscripciones impresas en la máquina, y familiarizarse con los comandos.
2. Estar formado y entrenado para el manejo de este aparato, bajo la responsabilidad de su empleador.
3. Realizar las operaciones de mantenimiento de acuerdo con las instrucciones del fabricante.
4. No utilizar el aparato en caso de avería.
5. No limpiar el aparato con agua a alta presión.
6. No modificar el aparato sin el consentimiento del fabricante.
7. No utilizar el aparato como masa de soldadura.
8. No soldar en el aparato sin desconectar los bornes de las baterías. Ver las instrucciones en el manual de mantenimiento.

INSPECCION DIARIA

1. Verificar el nivel de aceite hidráulico y el líquido de las baterías.
2. Comprobar que no haya signos evidentes de deterioración (fugas hidráulicas, burbujeo, contactos eléctricos).
3. Comprobar que el botón de parada de emergencia funcione correctamente.

INSTRUCCIONES PREVIAS A LA UTILIZACION

1. Quitar el botón de bloqueo de orientación (si lo hubiera).
2. **IMPORTANTE.** La toma debe conectarse a una instalación eléctrica protegida por un interruptor de 30 mA (NORMA CIS 100).

PUESTA EN MARCHA

1. Desbloquear la parada de emergencia, y pulsar el botón de arranque.
2. Liberar el botón de parada de emergencia y pulsar el botón de arranque. Esperar a que el aparato se detenga antes de utilizarlo.

È INTERDICTION D'UTILISER L'APPAREIL PENDANT LA CHARGE DES BATTERIES

7814 342

BEWEGINGSANWIJZINGEN
OM DE TOESTEL BEVEEGEN
MOET DE OPERATOR

1. Het informatie en de bedieningsinstructies en de aanwijzingen op de machine lezen en zich vertrouwd maken met de bedieningsinstructies.
2. Het apparaat moet en getraind zijn voor de bediening van deze machine, onder de verantwoordelijkheid van zijn werkgever.
3. Het onderhoud en de reparaties moeten volgens de instructies van de fabrikant worden uitgevoerd.
4. Het apparaat niet gebruiken bij storingen.
5. Het apparaat niet reinigen met hoge druk water.
6. Het apparaat niet wijzigen zonder de fabrikant te raadplegen.
7. Het apparaat niet gebruiken als lasmassa.
8. Het apparaat niet solderen zonder de batterijen te ontkoppelen. Zie de handleiding voor het onderhoud en de reparatie.

TAGELIJKSE KONTROLE

1. Het peil van de hydraulische olie en de accu's vloeistof.
2. Controleer of er geen tekenen van versleten of beschadigde onderdelen zijn.
3. Controleer of de noodstopknop goed werkt.

VOOR DE ERFAAT

1. De blokkeerpin verwijderen (indien van toepassing).
2. **WICHTIG.** Het stopcontact moet worden aangesloten op een beveiligd elektrisch systeem (30 mA).

INSCHAKELING

1. De machine veiligstellen en de startknop indrukken.
2. De noodstopknop loslaten en de startknop indrukken.

È INTERDICTION D'UTILISER L'APPAREIL PENDANT LA CHARGE DES BATTERIES

7814 342

6.7.3 - "Red" labels

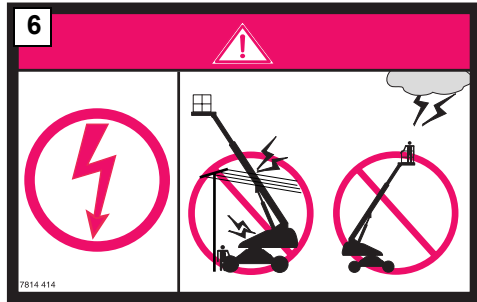
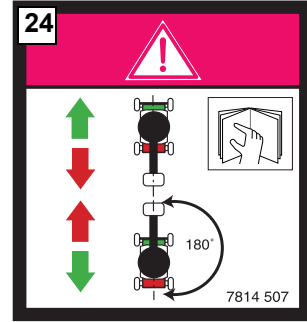
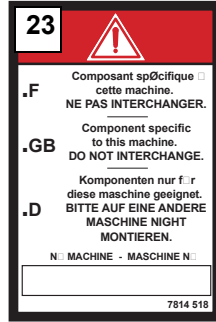
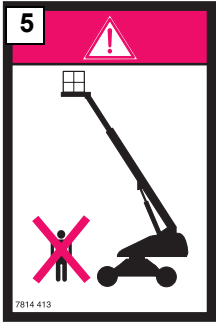

H21T(X)

H23T(X)

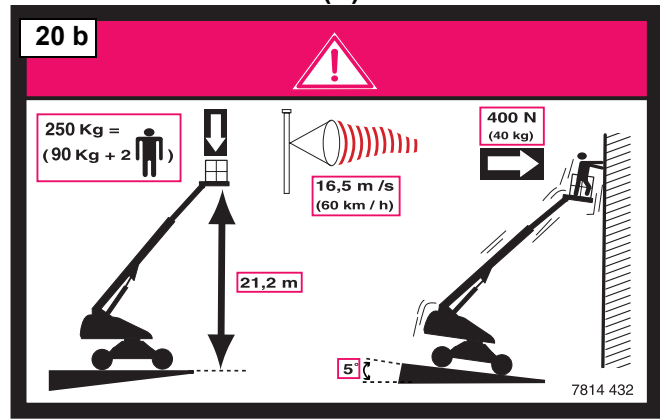
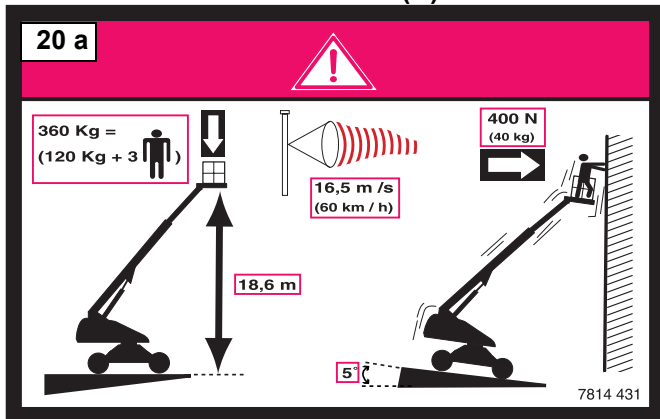

H23TP(X)

H25TP(X)

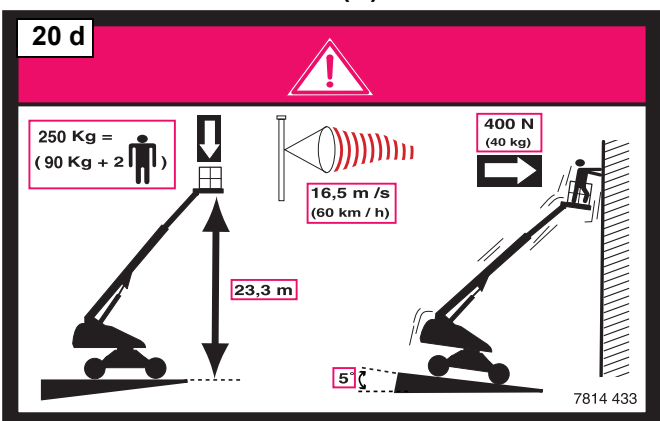
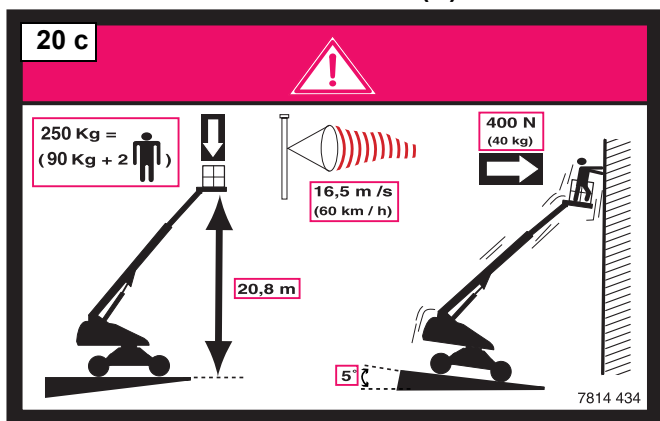

6.7.4 - Other labels

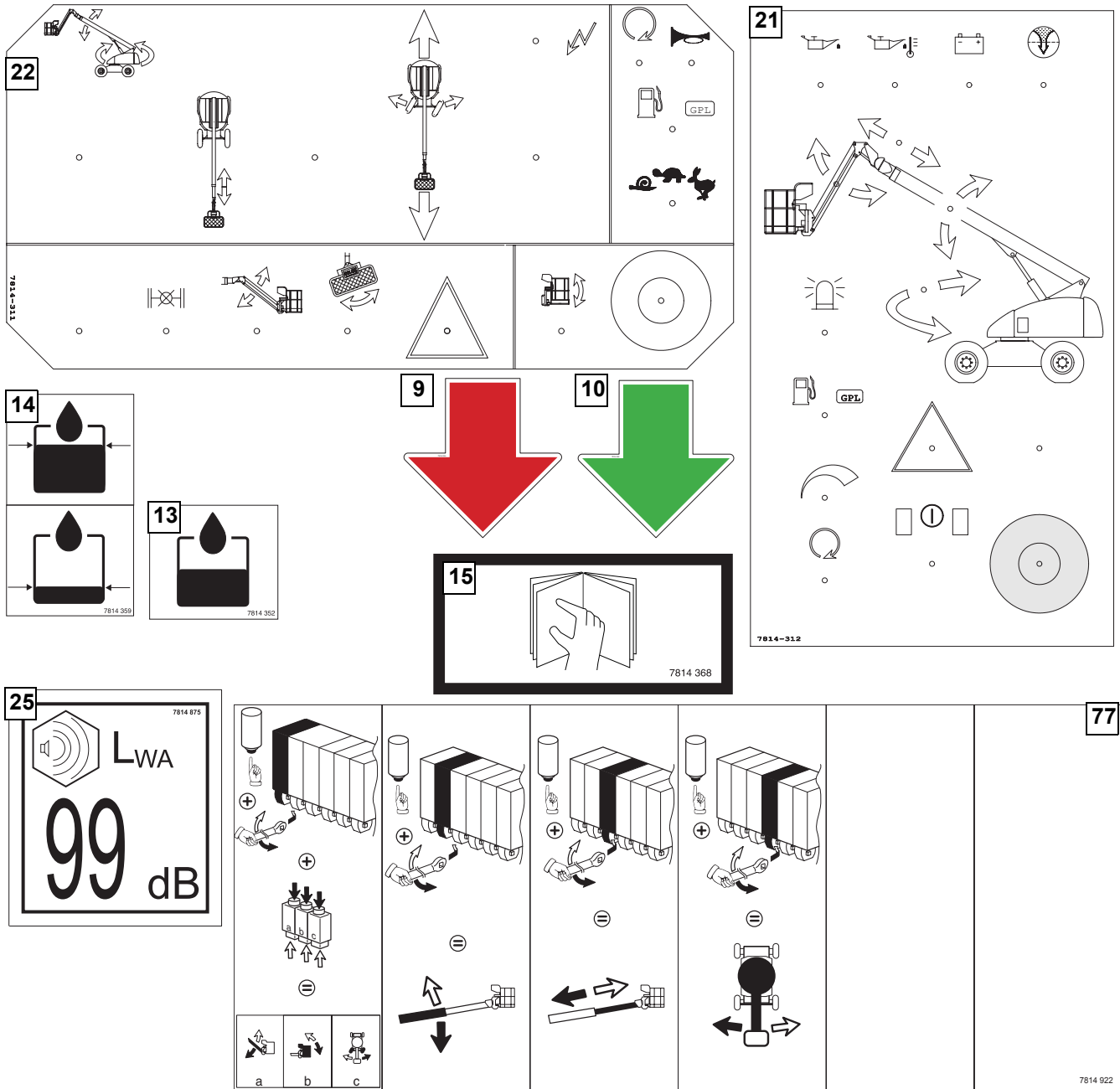

6.7.5 - Option

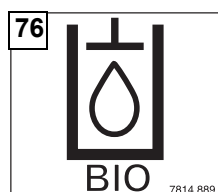

6.7.6 - Positions of labels

Ref	Code	Qty	Description
1	3078143240a	1	Manufacturer's plate (French)
	3078143250a		Manufacturer's plate (Spanish)
	3078143260b		Manufacturer's plate (German)
	3078143270a		Manufacturer's plate (English)
	3078143280a		Manufacturer's plate (Italian)
	3078143290a		Manufacturer's plate (Dutch)
	3078144960a		Manufacturer's plate (Danish)
	3078145550a		Manufacturer's plate (Finnish)
	3078145840a		Manufacturer's plate (Portuguese)
	3078145950a		Manufacturer's plate (Swedish)
2	3078143420	1	Operating instructions (French)
	3078143430		Operating instructions (Spanish)
	3078143440		Operating instructions (German)
	3078143450		Operating instructions (English)
	3078143460		Operating instructions (Italian)
	3078143470		Operating instructions (Dutch)
	3078144940		Operating instructions (Danish)
	3078145540		Operating instructions (Finnish)
	3078145830		Operating instructions (Portuguese)
	3078145940		Operating instructions (Swedish)
3078144560	Operating instructions (Australia)		
3	3078143600	2	Do not use as a welding earth. Do not wash...
4	3078143540	1	The plug must be connected to (...) 220 V.
5	3078144130	2	Do not stop in the machine's work area.
6	3078144140	1	This machine is not insulated. Danger of electrocution.
7	3078143620	2	Risk of crushing (hands and fingers)
8	3078143630	2	Risk of crushing (body)
9	3078143940	1	Red arrow (reverse)
10	3078143930	1	Green arrow (forwards)
11	3078143530	1	Remove the front turntable rotation pin
12	3078143570	1	Slew ring lubrication
13	3078143520	1	Hydraulic oil
14	3078143590	1	Hydraulic oil (high and low level)
15	3078143680	1	Read the operation and maintenance manual
16	3078138990	2	«H21T»
	3078139000		«H23T»
	3078140080		«H23TP»
	3078139010		«H25TP»
17	1250127590	1	«Haulotte»
18	3070029541	2	«Haulotte»
19	3078136770	2	«X»
20a	3078144310	1	Floor height + load capacity H21T(X)
20b	3078144320	1	Floor height + load capacity H23T(X)
20c	3078144330	1	Floor height + load capacity H23TP(X)
20d	3078144340	1	Floor height + load capacity H25TP(X)
21	3078143120	1	Turntable box label
22	3078143110	1	Platform box label
23	3078145180	1	Do not interchange (multi-language)
24	3078145070	1	DANGER - travel direction after rotation
25	3078148750	1	Acoustic power
76	3078148890	1	Biodegradable oil (option)
77	3078149220	1	Manual emergency assistance

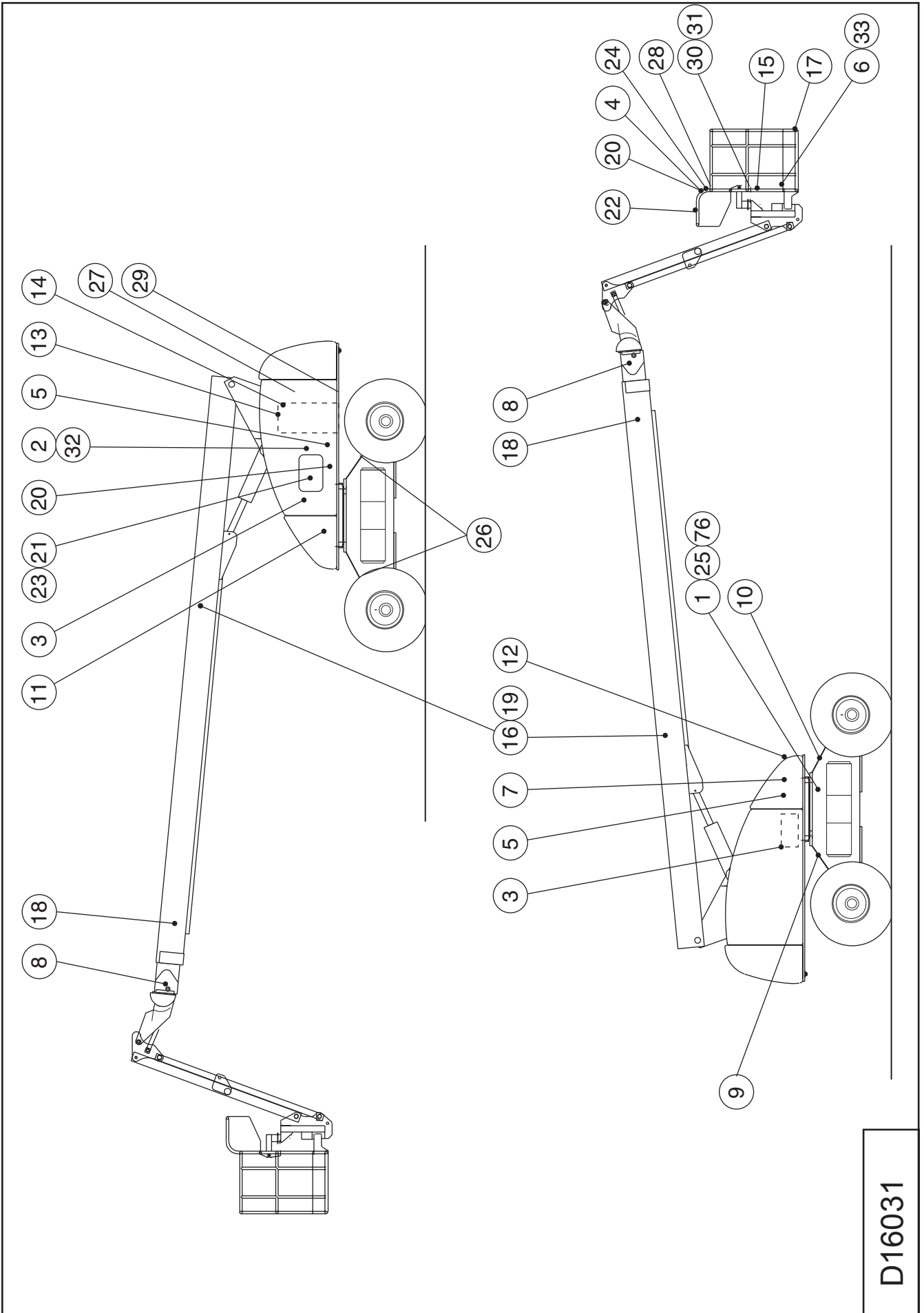

D16031

6.8 - PRESENCE OF MANUALS

Check that the manuals supplied with the machine are in good condition and stored in the document holder provided on the platform.

An illegible manual may result in incorrect or dangerous use of the machine.

Instructions:

Check the presence of the manuals:

Check that all the manuals are legible, complete and stored in the document holder on the platform. Replace the manuals if necessary (additional copies can be supplied on request by the manufacturer if necessary).

7 - PREVENTIVE MAINTENANCE SHEETS

List of preventive maintenance sheets

<i>Sheet no.</i>	<i>Description</i>
FICHE P007	Checking - changing the oil of a wheel reducing gear
FICHE P008	Checking - filling the hydraulic oil tank
FICHE P009	Changing the hydraulic filter cartridge

Sheet P007	PREVENTIVE MAINTENANCE SHEET	Folio 1/1
	CHECKING - CHANGING THE OIL OF A WHEEL REDUCING GEAR	



Caution!

Use a container to collect oil to prevent pollution of the environment.



Caution!

Make sure that the machine is properly stabilised, and that the lifting means are in good condition and of sufficient capacity.

1 - Preliminary operations

- Put the machine in the maintenance configuration (see § 6.3, page 32).
- Switch off electric power (see § 6.4, page 32).

2 - Checking the level

- Turn the wheel so that one cap (1) is on a horizontal line and the other (2) is on a vertical line.
- Unscrew the cap (1) and check the level that should be up to the hole. Top up if necessary.
- Screw the cap back into place.

NB: *Only use the oil recommended by the manufacturer.*

3 - Changing the oil

- In the same position, unscrew the 2 caps and let the oil flow out.
- Re-fill as described above.
- Screw the caps back into place.

NB: *Collect old oil to prevent pollution of the environment.*

4 - Additional operations

- Put the machine back into the operational configuration.



HA16/18PX - HA46/51JRT
HA20/26 PX - HA61/80JRT



H14T(X) - H16TP(X)
HB40/44J

	PREVENTIVE MAINTENANCE SHEET	

Sheet P008	PREVENTIVE MAINTENANCE SHEET	Folio 1/1
	CHECKING - FILLING THE HYDRAULIC OIL TANK	

 **Caution!**
Put the machine in the folded position.

1 - Preliminary operations

- Put the machine in the maintenance configuration (see § 6.3 -).
- Switch off electric power (see § 6.4 -).

2 - Checking - filling the hydraulic oil tank

NB: This operation must be carried out when the oil is cold, i.e. before starting the machine.

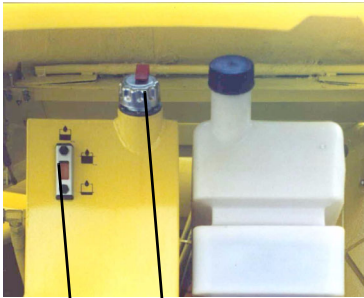

1 2

- Check that the level of oil (1) in the tank is between the high and low levels when cold.
- Top up if necessary, by filling via the cap (2).

NB: Only use the oil recommended by the manufacturer.

- Put the machine back into the operational configuration.

Sheet P009	PREVENTIVE MAINTENANCE SHEET	Folio 1/1
	CHANGING THE HYDRAULIC FILTER CARTRIDGE	

 **Caution!**
Use a container to collect oil to prevent pollution of the environment.

1 - Preliminary operations

- Put the machine in the maintenance configuration (see § 6.3 -).
- Switch off electric power (see § 6.4 -).

2 - Replacing the hydraulic filter cartridge

NB: The filter has a clogging indicator. Clogging should be checked when the machine is hot, otherwise, the indicator may be visible due to the viscosity of the cold oil.

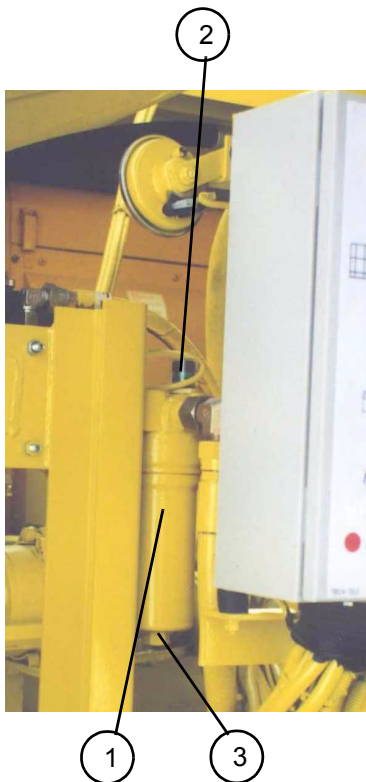

- Change the cartridge (1) if the clogging indicator appears (2).
- Unscrew the base nut (3) and remove the cartridge from the hydraulic filter.
- Screw a new cartridge into place.
- Put the machine back into the operational configuration.

8 - OPERATING INCIDENTS

8.1 - INCIDENT TABLE

Before diagnosing a failure, check that:

- the fuel tank is not empty,
- the batteries are properly charged,
- the turntable and platform "palm button" emergency stop buttons are unlocked,
- the relays (platform control panel - turntable box) are correctly pushed into their compartments, (see § 4.2 -),
- the main tank oil level is OK,
- the state of the fuses, (see § 4.2 -),
- the electrovalves are working properly by checking the state of the LEDs in the turntable box.

Check the state of the LEDs (see § 4.2 -):

The LEDs inside the turntable box indicate the state of the electrovalves:

- LED off: electrovalve present and not controlled,
- LED on (weak light): electrovalve not connected,
- LED on (strong light): electrovalve present and controlled.

NB: If an electrovalve is not connected, the corresponding LED is permanently on.

Instructions:

- Identify the defective function.
- Machine power on but not started: check the presence of the electrovalves (LED off).
- No electrovalve should be controlled (LED on).
- Check that the outputs corresponding to the function are active using the LEDs and directly on the electrovalve heads.
- If they are not active, check which inputs create the function.
- Test the inputs with a voltmeter.

8.1.1 - General operation

ANOMALY	PROBABLE CAUSE	SOLUTION
The motor does not start, the starter is activated	<ul style="list-style-type: none"> • Diesel tank empty • Fuse FU1 defective • Diesel supply circuit defective • Wiring defective • Module U1 defective • Stop motor solenoid YA1 defective 	Sheet DP015
The motor does not start, the starter is not activated	<ul style="list-style-type: none"> • Emergency stop locked • Generator defective • Batteries defective • Fuses FU1, FU4 or FU8 defective • Wiring defective • Switch SB3 or SB4 defective • Relay KA2 defective • U3 frequency module defective 	Sheet DP016
The motor starts, then stops after 5s.	<ul style="list-style-type: none"> • Diesel tank empty • Diesel supply circuit defective 	Sheet DP041
The motor does not start from the platform panel but does start from the turntable panel	<ul style="list-style-type: none"> • Fuse FU6 defective • Defective connection of switch SB4 • Switch SB4 defective • Wiring harness defective 	Sheet DP019
The motor does not start from the turntable panel but does start from the platform panel	<ul style="list-style-type: none"> • Switch SB3 defective • Wiring harness defective 	Sheet DP020
No motor acceleration regardless of the movement controlled from the platform	<ul style="list-style-type: none"> • Electronic module U1 defective • Wiring harness defective 	Sheet DP021
No motor acceleration by activating the accelerator switch SA2 on the turntable control panel	<ul style="list-style-type: none"> • Relay KT2 defective • Electronic module U1 defective • Wiring harness defective • Accelerator switch SA2 defective • Motor accelerator coil YA2 defective 	Sheet DP022
No movement available (from turntable or platform panel)	<ul style="list-style-type: none"> • Insufficient hydraulic oil • Fuse FU7 or FU4 or FU10 defective • Wiring harness defective • Electrovalve YV1 defective • Incorrect "Load sensing" pressure setting • Motor-pump coupling defective • Hydraulic pump defective • Pressure limiter defective • Distribution block input module defective • Pump regulation unit incorrectly set or defective • Hydraulic pump defective • Electronic module U1 defective • Relay KMG defective • Printed circuit defective • Key switch SA1 defective 	Sheet DP023

ANOMALY	PROBABLE CAUSE	SOLUTION
No movement available from the platform control panel	<ul style="list-style-type: none"> • Fuse FU1 defective • Platform control panel defective • Fail-safe pedal defective • Wiring harness defective 	Sheet DP024
Noisy hydraulic pump	<ul style="list-style-type: none"> • Oil non-conform • Obstruction of the tank air vent • Suction valves closed • Defective pipes • Hydraulic pump defective • Insufficient oil level • Cavitation 	Sheet DP025
Insufficient pressure or power at the pump	<ul style="list-style-type: none"> • Clogged air filter • Motor speed too low • Oil leak on connector, hose or component • Clogged diesel filter 	<ul style="list-style-type: none"> • Change the filter • See manufacturer's manual • Repair or replace • Replace diesel filter cartridge
No travel telescope out, boom and arm lifting, + buzzer sounding	<ul style="list-style-type: none"> • Slope or tilt >5° 	<ul style="list-style-type: none"> • First retract the telescope and lower the boom to reset
Buzzer sounding	<ul style="list-style-type: none"> • Slope or tilt > 5° • Platform load close to cut-off • Hydraulic oil temperature too high 	<ul style="list-style-type: none"> • Reset by retracting the telescope and lowering the boom • Remove load • Leave to cool
The electropump does not work	<ul style="list-style-type: none"> • Battery breaker open • Fuses broken • Defective or discharged batteries • Electropump unit defective • The battery wires do not make contact 	<ul style="list-style-type: none"> • Close the battery breaker • Replace the fuses • Replace or recharge the batteries • Repair or replace the unit • Clean and tighten the terminals

8.1.2 - Lifting system

ANOMALY	PROBABLE CAUSE	SOLUTION
No platform up and/or down compensation movement	<ul style="list-style-type: none"> • Electrovalve YV19 or YV2 defective • Coil defective • Electronic module U1 defective • Wiring harness defective • Printed circuit defective • Compensation switch SA5 defective • Lifting manipulator defective 	Sheet DP050
The compensation movement is made in response to a platform rotation control	<ul style="list-style-type: none"> • Electrovalve YV24 defective • Coil defective • Electronic module U1 defective • Wiring harness defective • Printed circuit defective 	Sheet DP051
No jib movement (up and / or down) from the platform (or turntable) control panel	<ul style="list-style-type: none"> • Electrovalve YV18 or YV2 defective • Coil defective • Electronic module U1 defective • Wiring harness defective • Printed circuit defective • Jib switch SA7 or SA6 defective 	Sheet DP028
No telescoping movement (out and/or in) from the platform (or turntable) control panel	<ul style="list-style-type: none"> • Electrovalve YV4 defective • Electronic module U1 defective • Wiring harness defective • Printed circuit defective • Telescoping switch SA8 defective • Telescoping manipulator SM2 defective 	Sheet DP053
No boom lifting movement (up and/or down) from the platform (or turntable) control panel	<ul style="list-style-type: none"> • Electrovalve YV3 defective • Electronic module U1 defective • Wiring harness defective • Printed circuit defective • Lifting switch SA13 defective • Lifting manipulator SM31 defective 	Sheet DP054

8.1.3 - Travel system

ANOMALY	PROBABLE CAUSE	SOLUTION
No machine travel movement	<ul style="list-style-type: none"> • Connectors disconnected • Manipulator HM4 defective • Wiring harness defective • Electronic module U1 defective • Coils of electrovalve YV6 or YV7 defective • Electrovalves YV6 or YV7 defective 	Sheet DP032
Only travel micro-speed remains available on the machine, regardless of the speed selected	<ul style="list-style-type: none"> • Machine unfolded • Contactors SQ2, SQ3, SQ4 incorrectly set or defective • Wiring harness defective • Electronic module U1 defective • Printed circuit defective 	Sheet DP056
Machine travel speed does not correspond to the selector	<ul style="list-style-type: none"> • Electrovalve YV8, YV10 or YV12 defective • Coil of electrovalve YV8, YV10 or YV12 defective • Wiring harness defective • Printed circuit defective • Speed selector SA11 defective • Electronic module U1 defective 	Sheet DP034
Sudden stop of travel during a platform lifting operation	<ul style="list-style-type: none"> • Contactors SQ3, SQ4, SQ2 incorrectly set or defective • Wiring harness defective • Electronic module U1 defective 	Sheet DP058
No differential blocking during action on switch SA3	<ul style="list-style-type: none"> • Switch SA3 or SA11 defective • Electronic module U1 defective • Wiring harness defective • Contactors SQ3, SQ4, SQ2 incorrectly set or defective • Printed circuit defective • Coils of electrovalves YV9 or YV13 defective • Electrovalves YV9 or YV13 defective 	Sheet DP036

8.1.4 - Steering system

ANOMALY	PROBABLE CAUSE	SOLUTION
No steering movement (right and/or left)	<ul style="list-style-type: none"> • Electrovalve YV18 or YV2 defective • Coil defective • Electronic module U1 defective • Wiring harness defective • Printed circuit defective • Manipulator SM4 defective 	Sheet DP060

8.1.5 - Turntable rotation system

ANOMALY	PROBABLE CAUSE	SOLUTION
No turntable rotation movement (right and/or left) from the platform (or turntable) control panel	<ul style="list-style-type: none"> • Electrovalve YV5 defective • Electronic module U1 defective • Wiring harness defective • Printed circuit defective • Rotation switch SA15 defective • Rotation manipulator SM31 defective 	Sheet DP042
The turntable does not turn	<ul style="list-style-type: none"> • The blocking pin has not been removed from the chassis 	<ul style="list-style-type: none"> • Remove the pin

NB: In the turntable box, LEDs indicate the state of each output so that you can check if an output is activated.

8.2 - BREAKDOWN DETECTION FLOW CHARTS

Sheet DP015	BREAKDOWN DETECTION FLOW CHART	Folio 1/2
	THE MOTOR DOES NOT START, THE STARTER IS ACTIVATED	

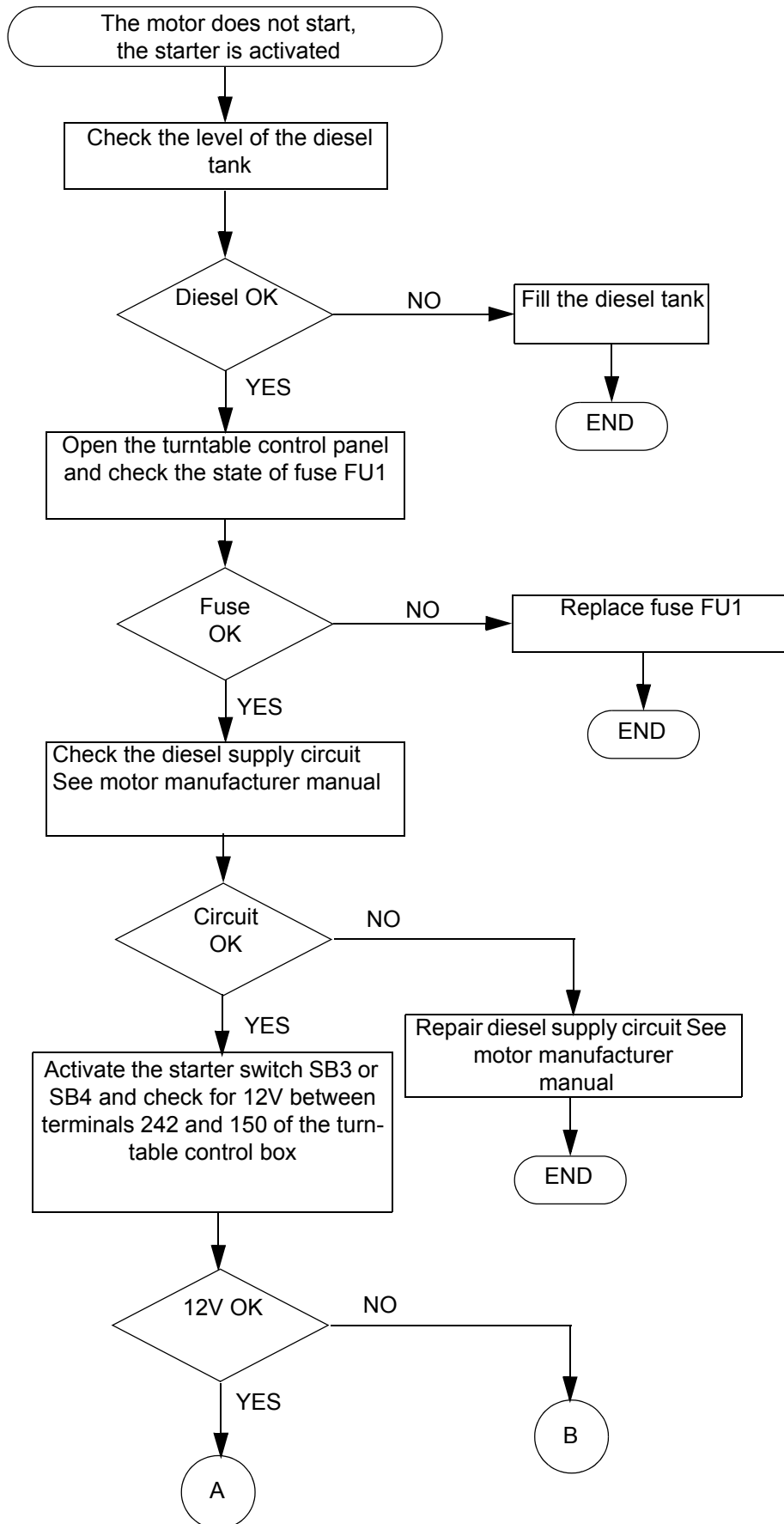

Sheet DP015	BREAKDOWN DETECTION FLOW CHART	Folio 2/2
	THE MOTOR DOES NOT START, THE STARTER IS ACTIVATED	

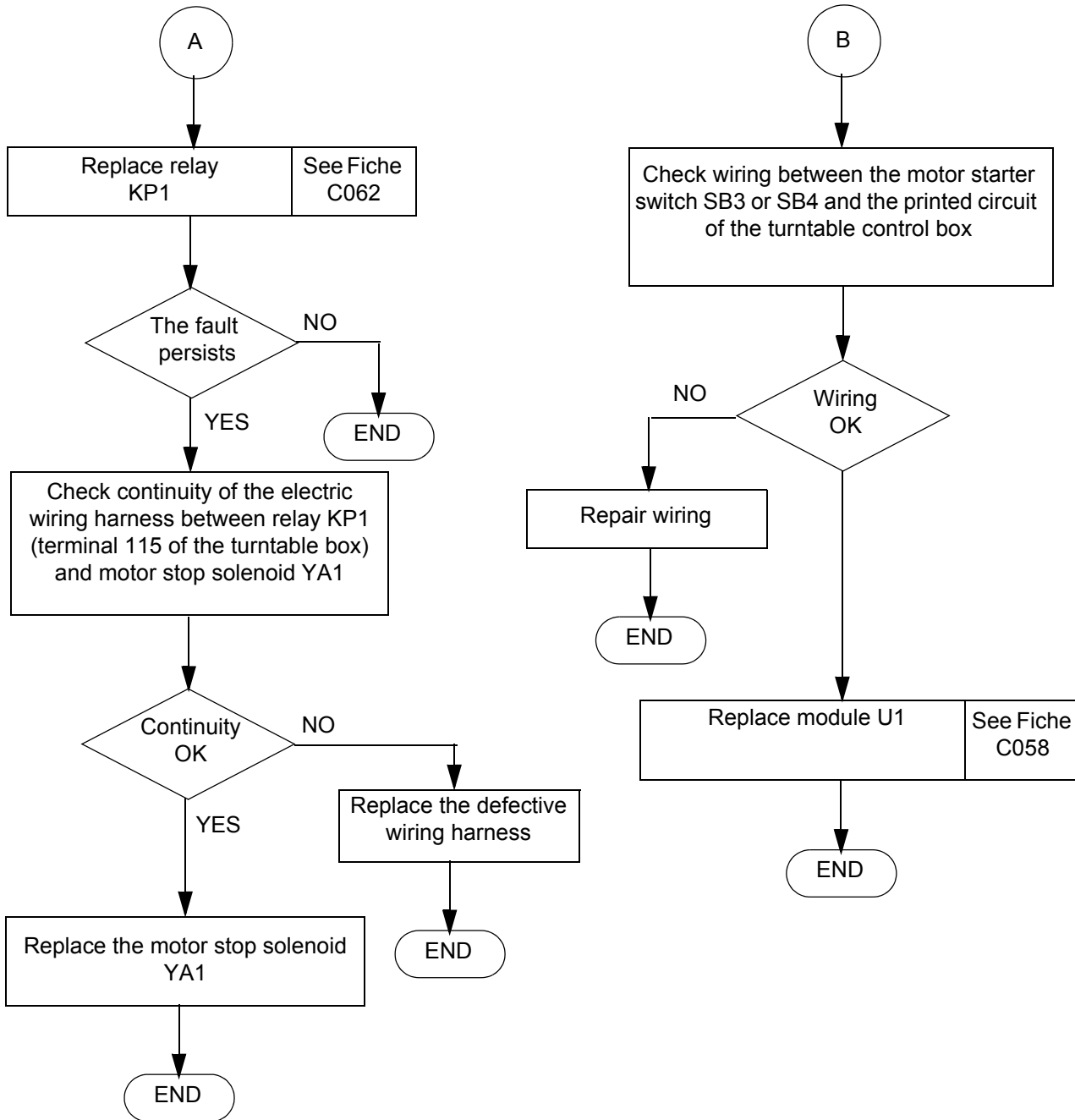

Sheet DP016	BREAKDOWN DETECTION FLOW CHART	Folio 1/3
	THE MOTOR DOES NOT START, THE STARTER IS NOT ACTIVATED	

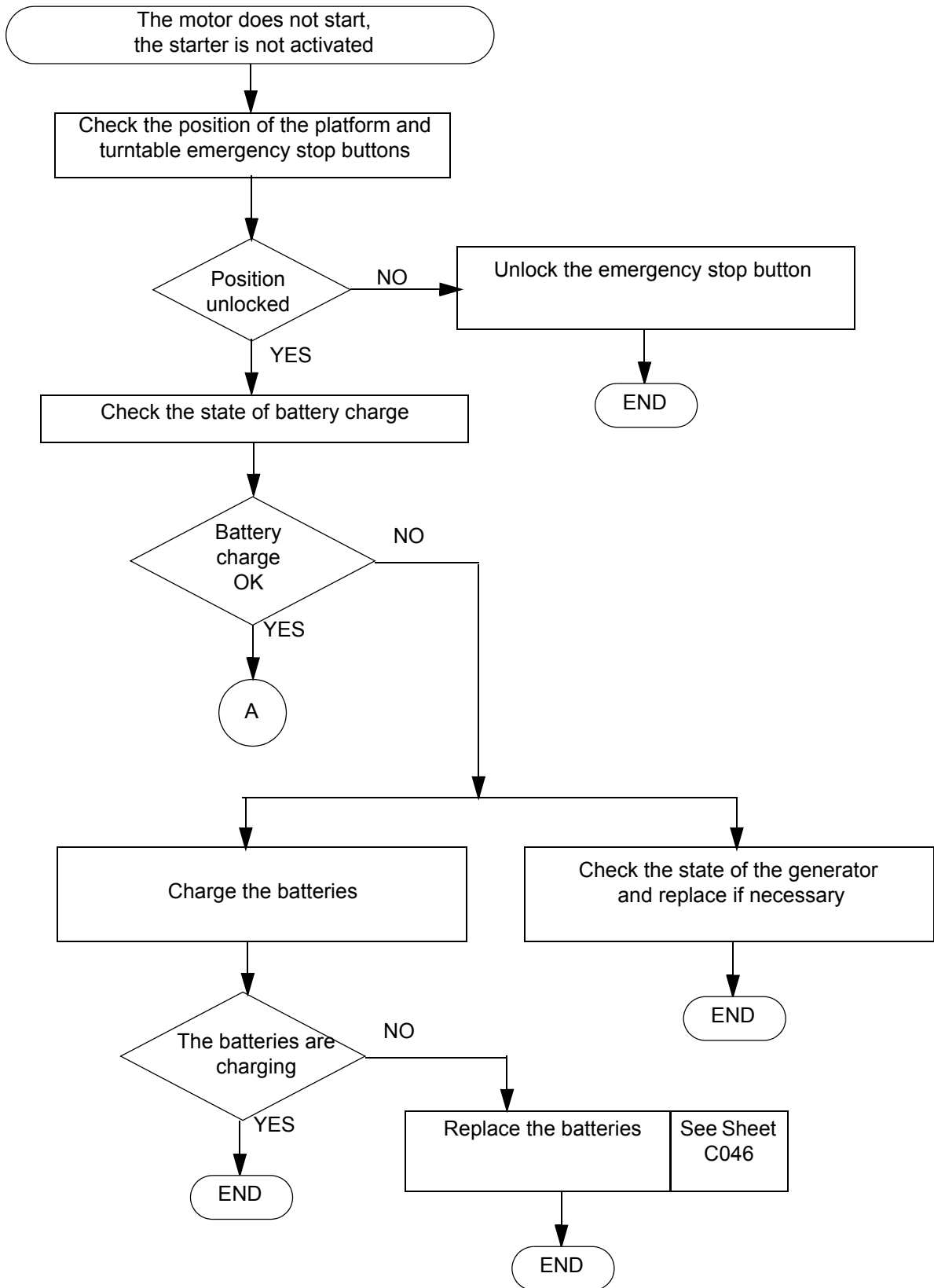

Sheet DP016	BREAKDOWN DETECTION FLOW CHART	Folio 2/3
	THE MOTOR DOES NOT START, THE STARTER IS NOT ACTIVATED	

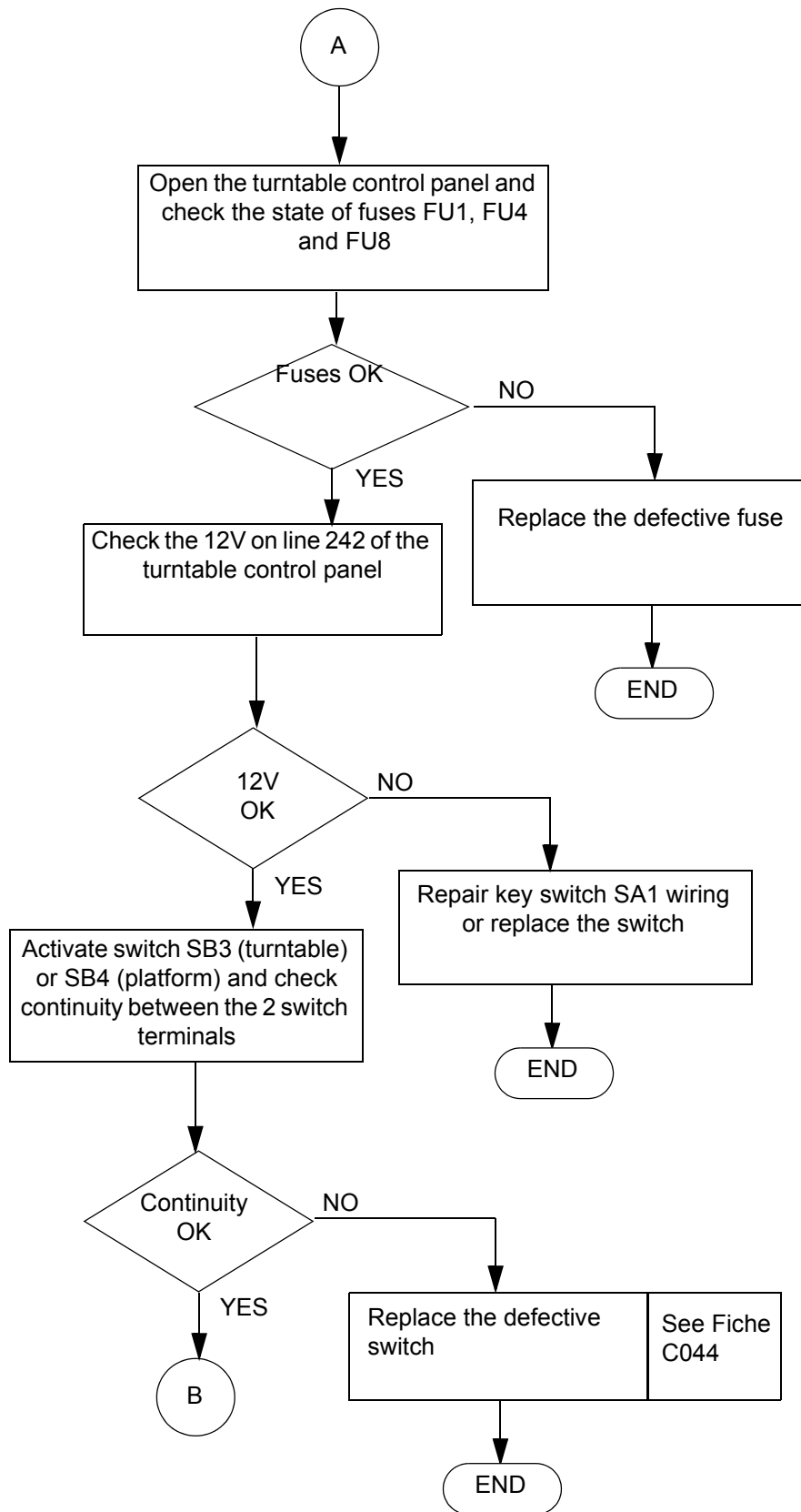

Sheet DP016	BREAKDOWN DETECTION FLOW CHART	Folio 3/3
	THE MOTOR DOES NOT START, THE STARTER IS NOT ACTIVATED	

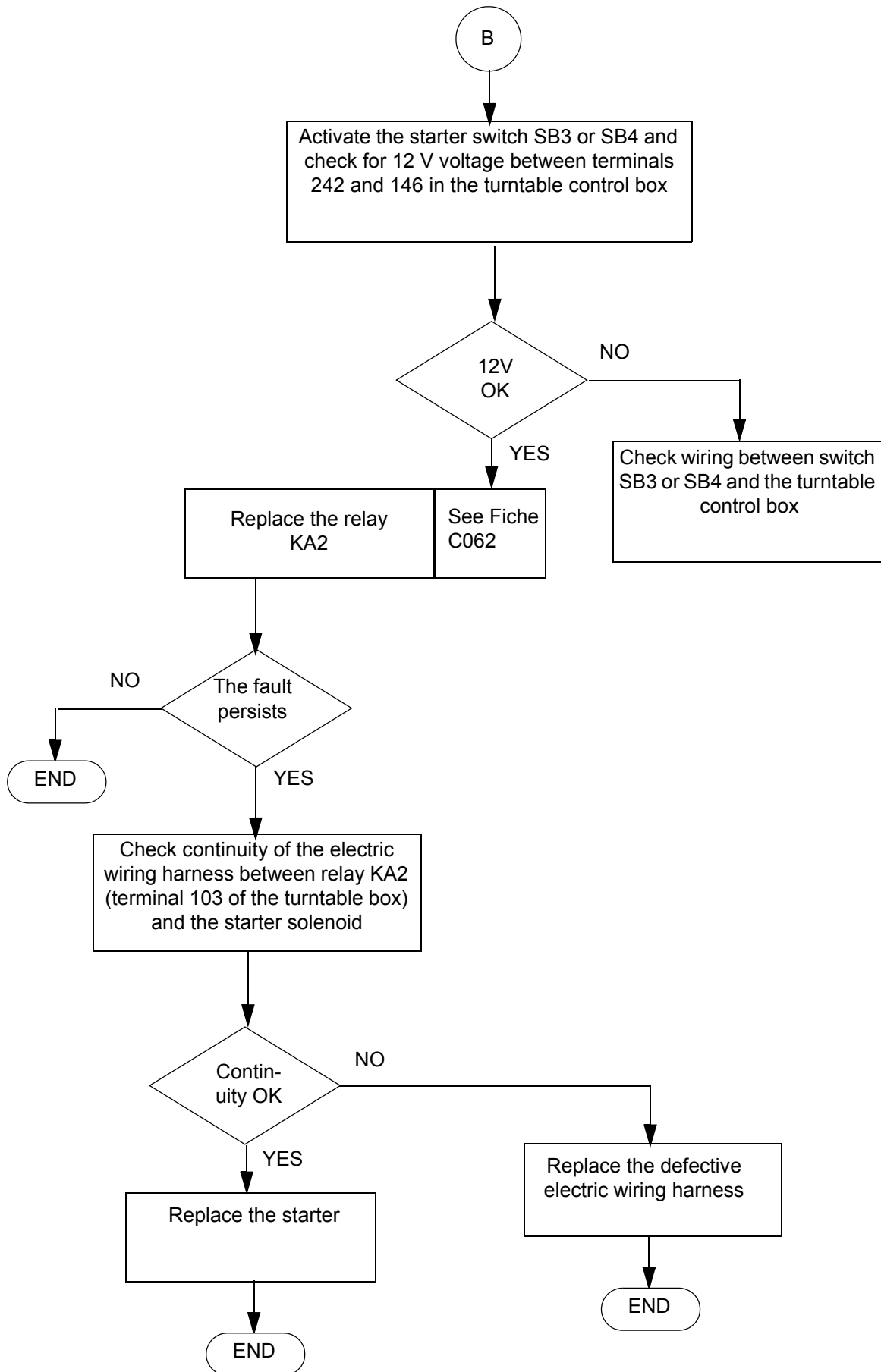

Sheet DP019	BREAKDOWN DETECTION FLOW CHART	Folio 1/2
	THE MOTOR DOES NOT START FROM THE PLATFORM PANEL BUT DOES START FROM THE TURNTABLE PANEL	

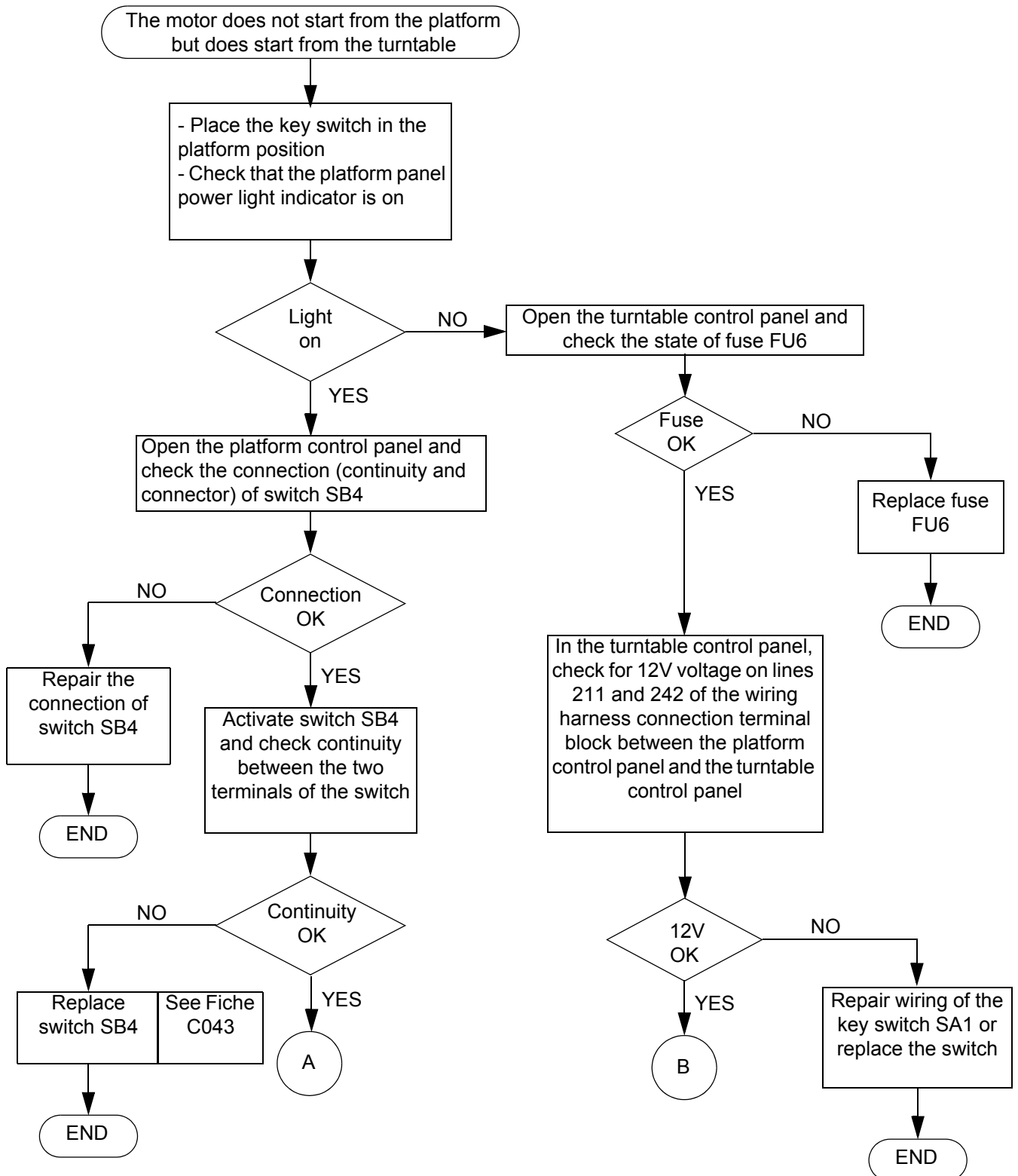

Sheet DP019	BREAKDOWN DETECTION FLOW CHART	Folio 2/2
	THE MOTOR DOES NOT START FROM THE PLATFORM PANEL BUT DOES START FROM THE TURNTABLE PANEL	

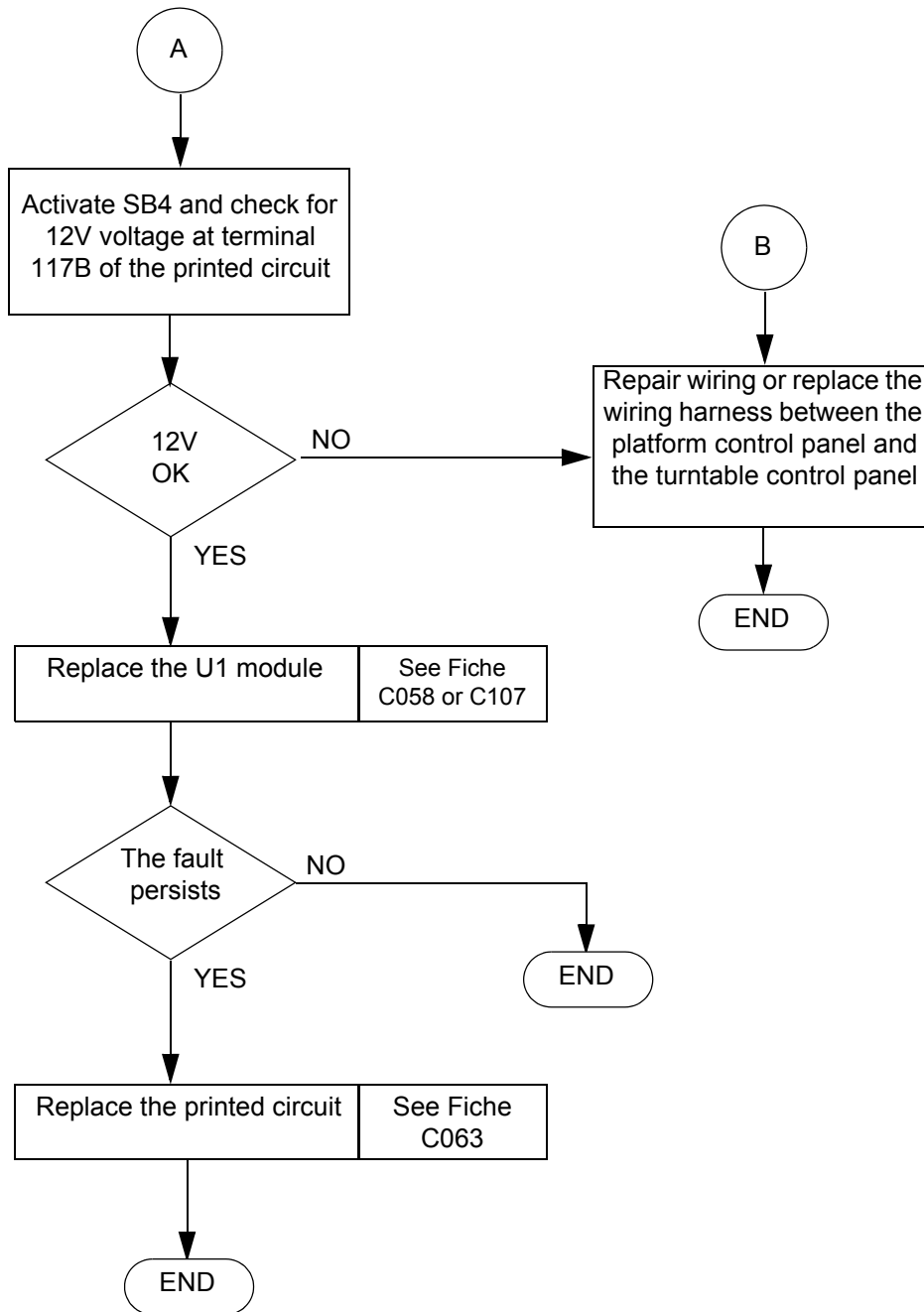

Sheet DP020	BREAKDOWN DETECTION FLOW CHART	Folio 1/1
	THE MOTOR DOES NOT START FROM THE TURNTABLE CONTROL PANEL BUT DOES START FROM THE PLATFORM CONTROL PANEL	

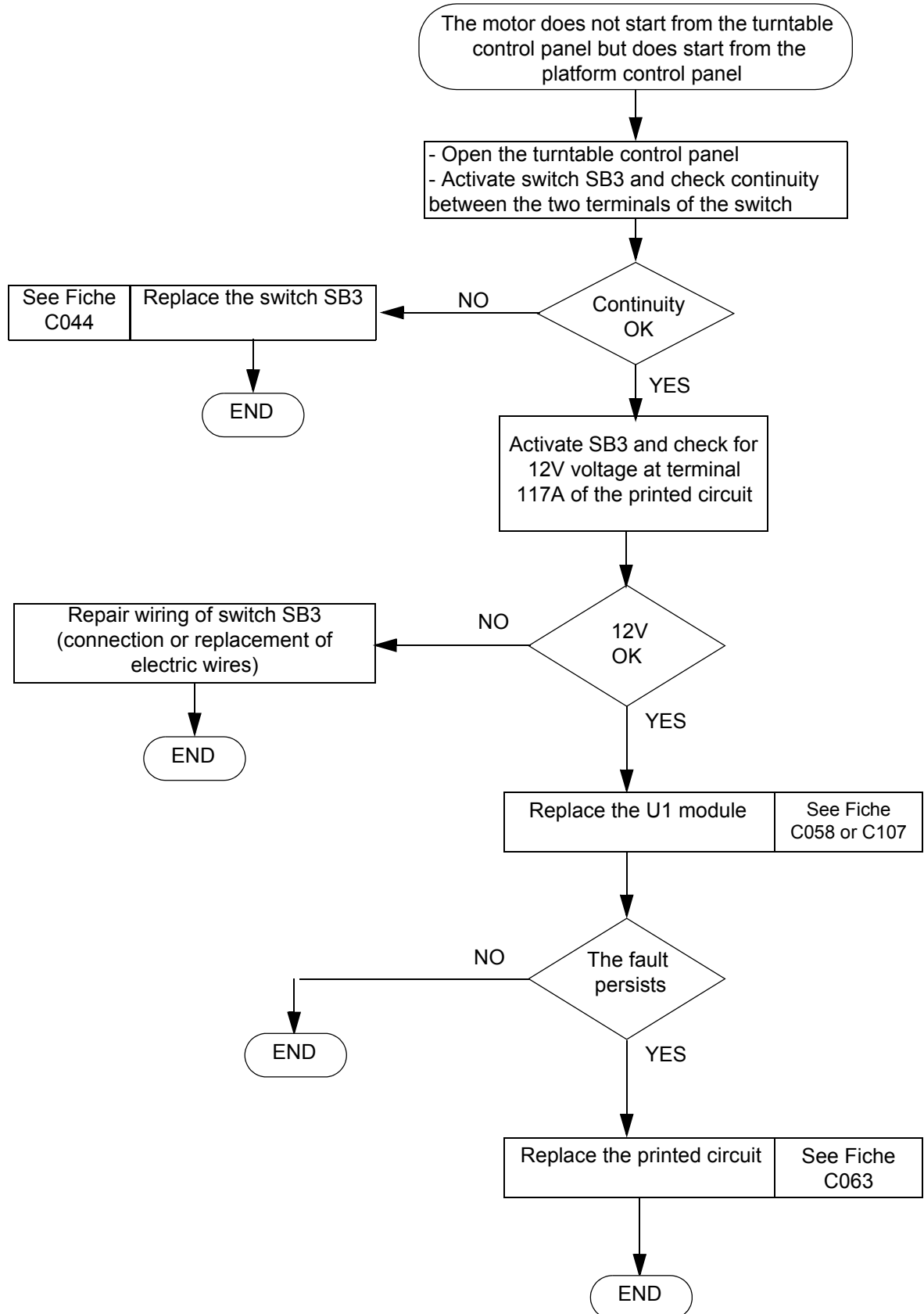

Sheet DP021	BREAKDOWN DETECTION FLOW CHART	Folio 1/1
	MOTOR ACCELERATION FOR ANY MOVEMENT CONTROLLED FROM THE PLATFORM (ACCELERATION, TRAVEL, LIFTING, TURNTABLE ROTATION, TELESCOPE)	

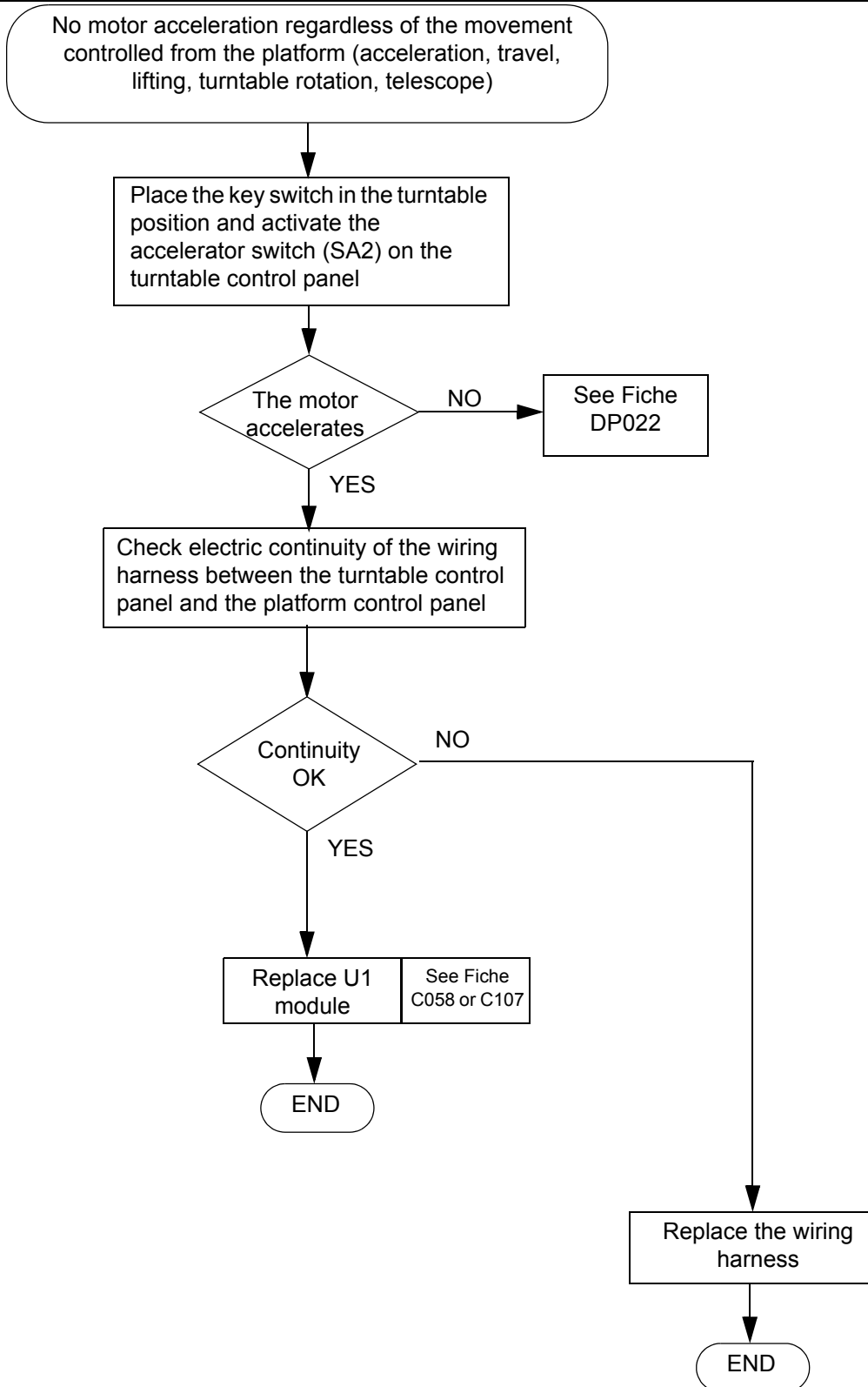

Sheet DP022	BREAKDOWN DETECTION FLOW CHART	Folio 1/2
	NO MOTOR ACCELERATION ON ACTIVATING THE ACCELERATOR SWITCH SA2 FROM THE TURNTABLE CONTROL PANEL	

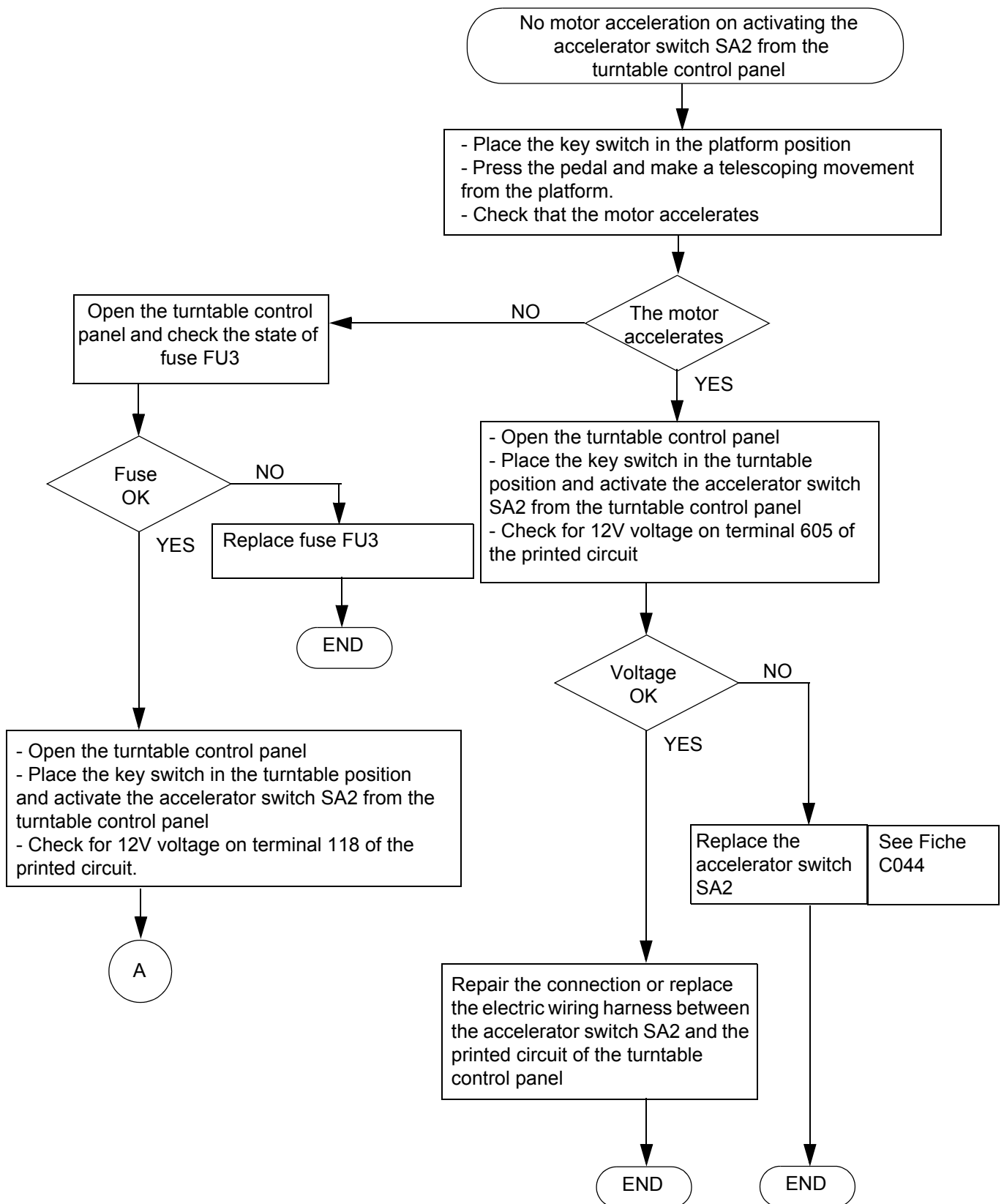

Sheet DP022	BREAKDOWN DETECTION FLOW CHART	Folio 2/2
	NO MOTOR ACCELERATION ON ACTIVATING THE ACCELERATOR SWITCH SA2 FROM THE TURNTABLE CONTROL PANEL	

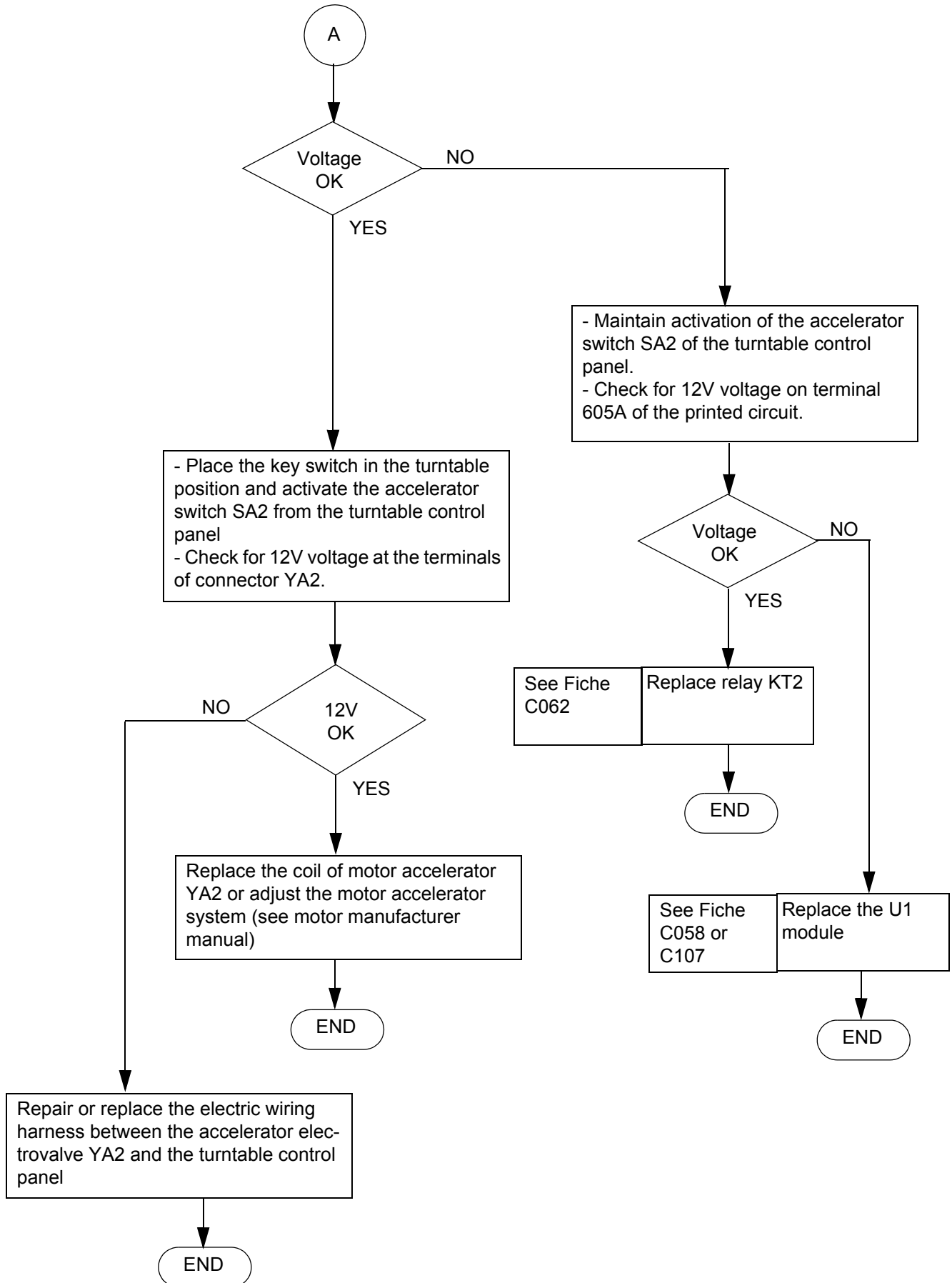

Sheet DP023	BREAKDOWN DETECTION FLOW CHART	Folio 1/5
	NO MOVEMENT AVAILABLE (FROM TURNTABLE OR PLATFORM CONTROL PANELS)	

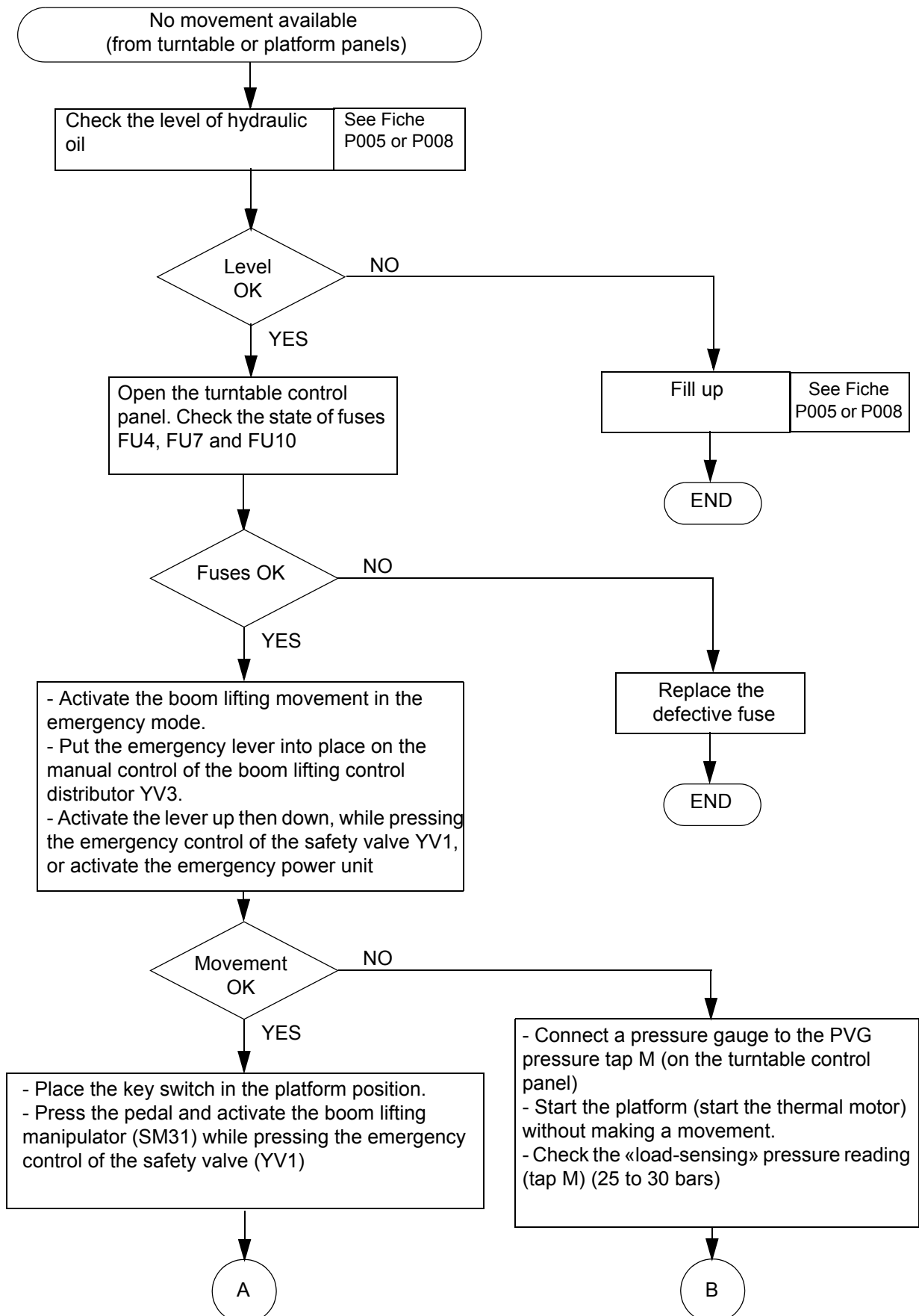

Sheet DP023	BREAKDOWN DETECTION FLOW CHART	Folio 2/5
	NO MOVEMENT AVAILABLE (FROM TURNTABLE OR PLATFORM CONTROL PANELS)	

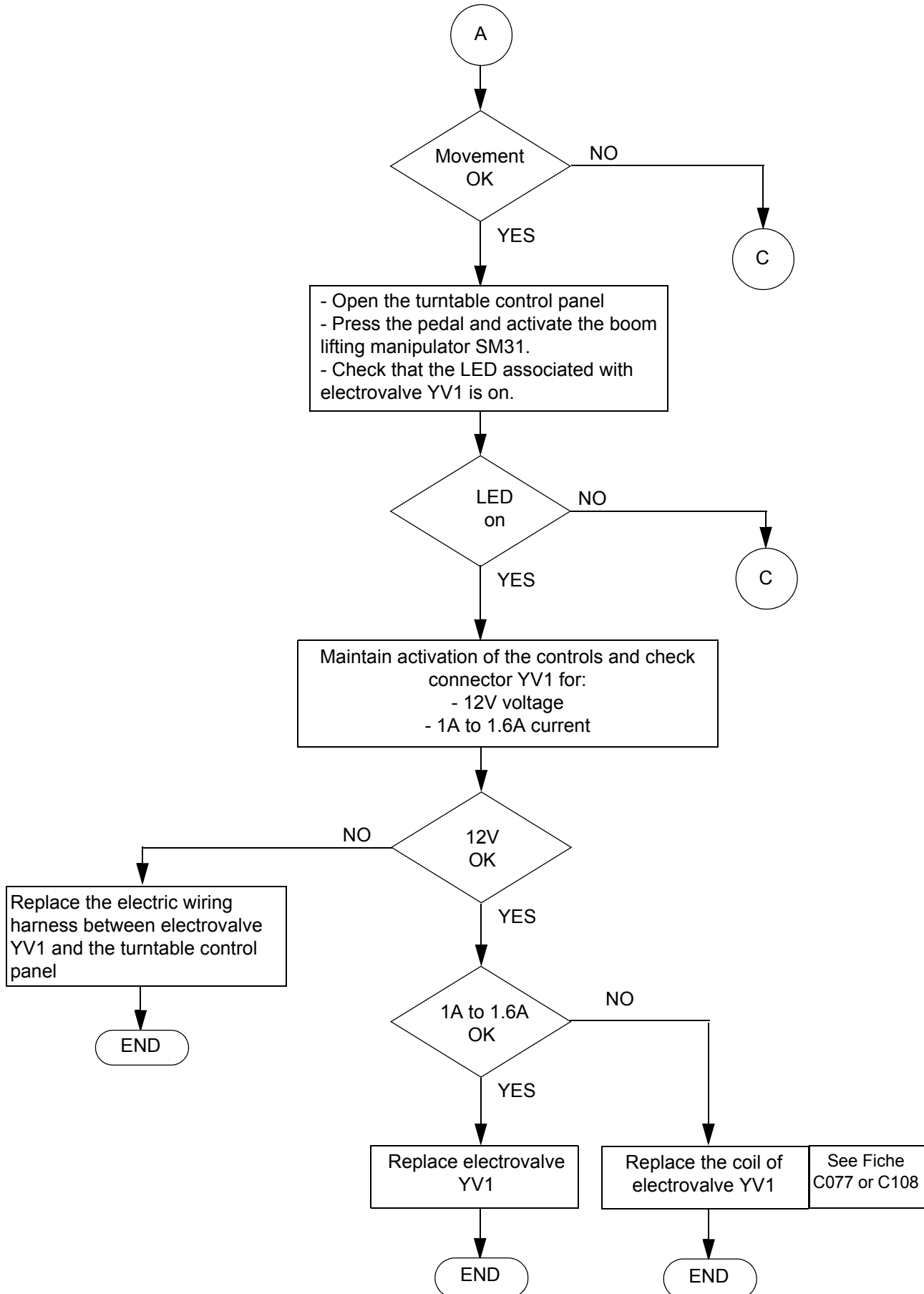

Sheet DP023	BREAKDOWN DETECTION FLOW CHART	Folio 3/5
	NO MOVEMENT AVAILABLE (FROM TURNTABLE OR PLATFORM CONTROL PANELS)	

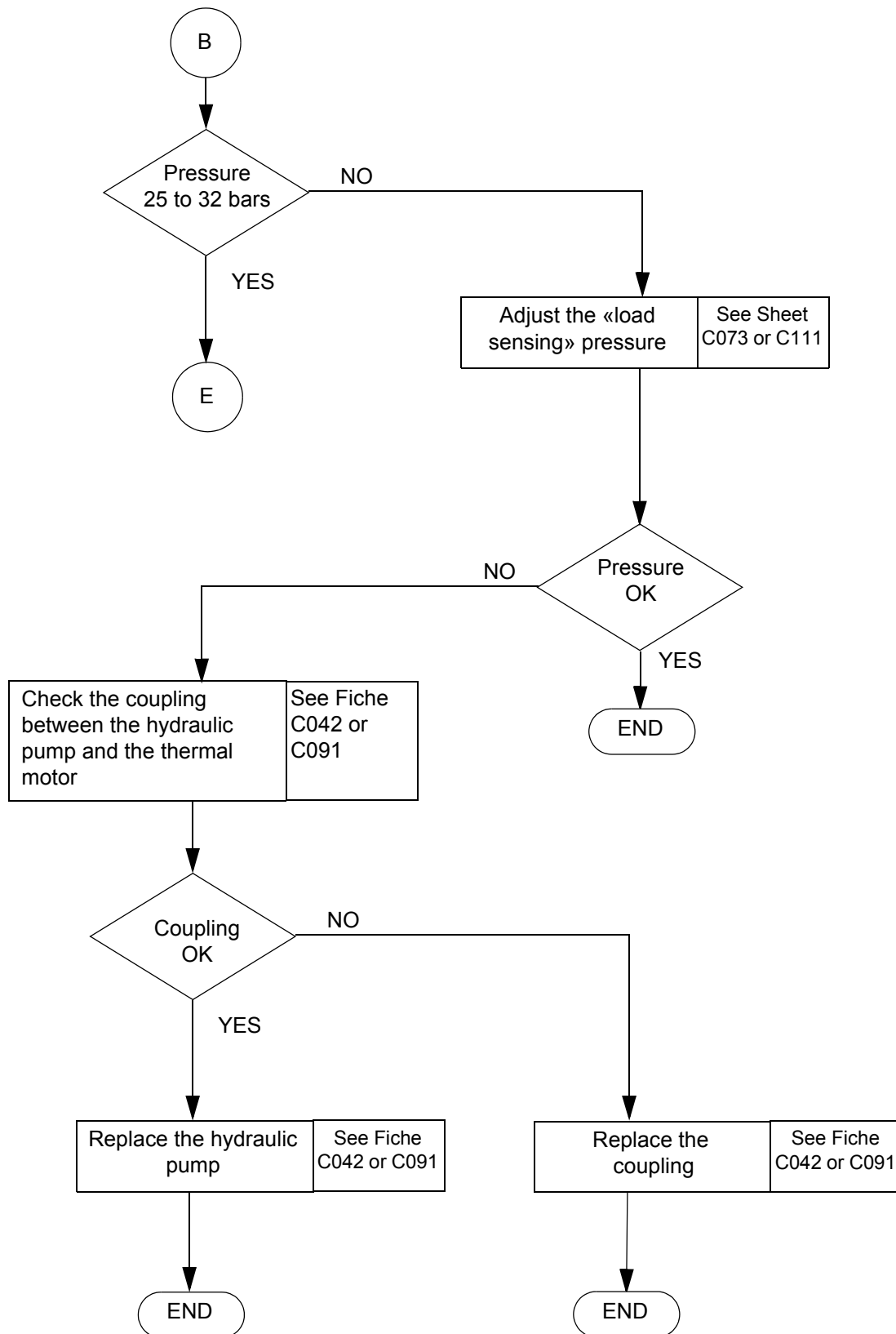

Sheet DP023	BREAKDOWN DETECTION FLOW CHART	Folio 4/5
	NO MOVEMENT AVAILABLE (FROM TURNTABLE OR PLATFORM CONTROL PANELS)	

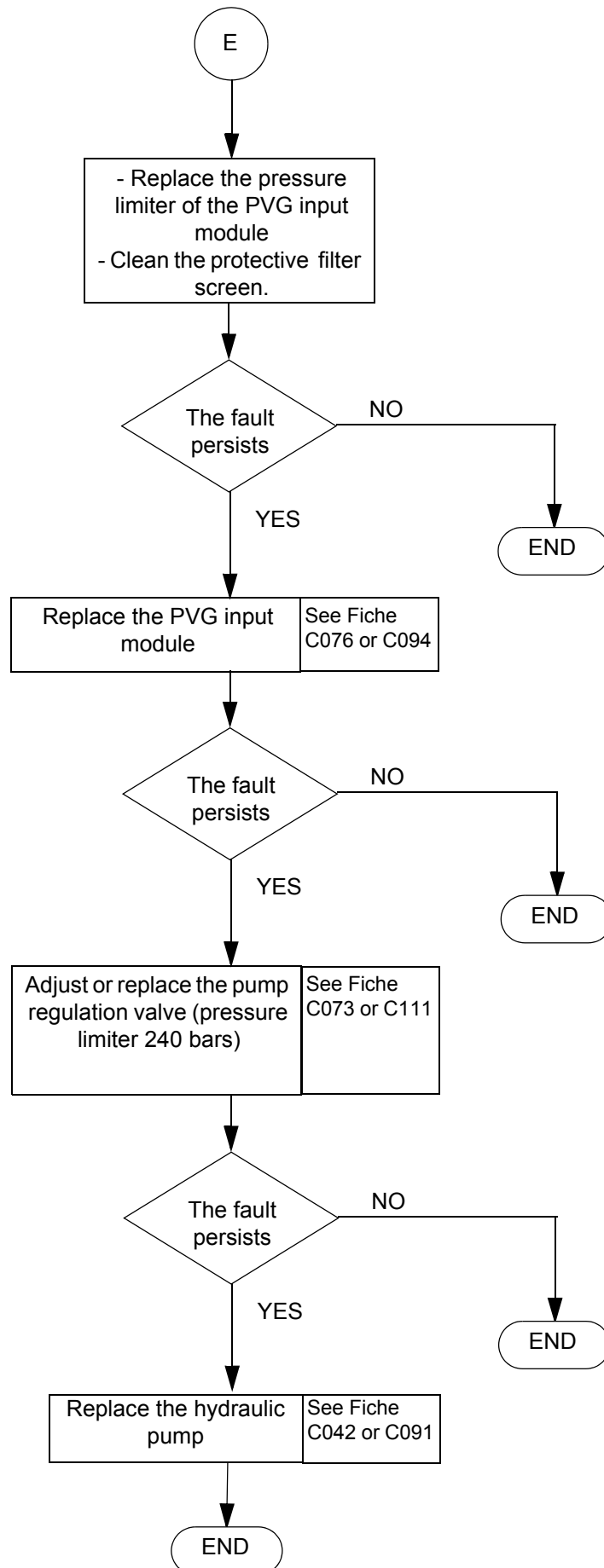

Sheet DP023	BREAKDOWN DETECTION FLOW CHART	Folio 5/5
	NO MOVEMENT AVAILABLE (FROM TURNTABLE OR PLATFORM CONTROL PANELS)	

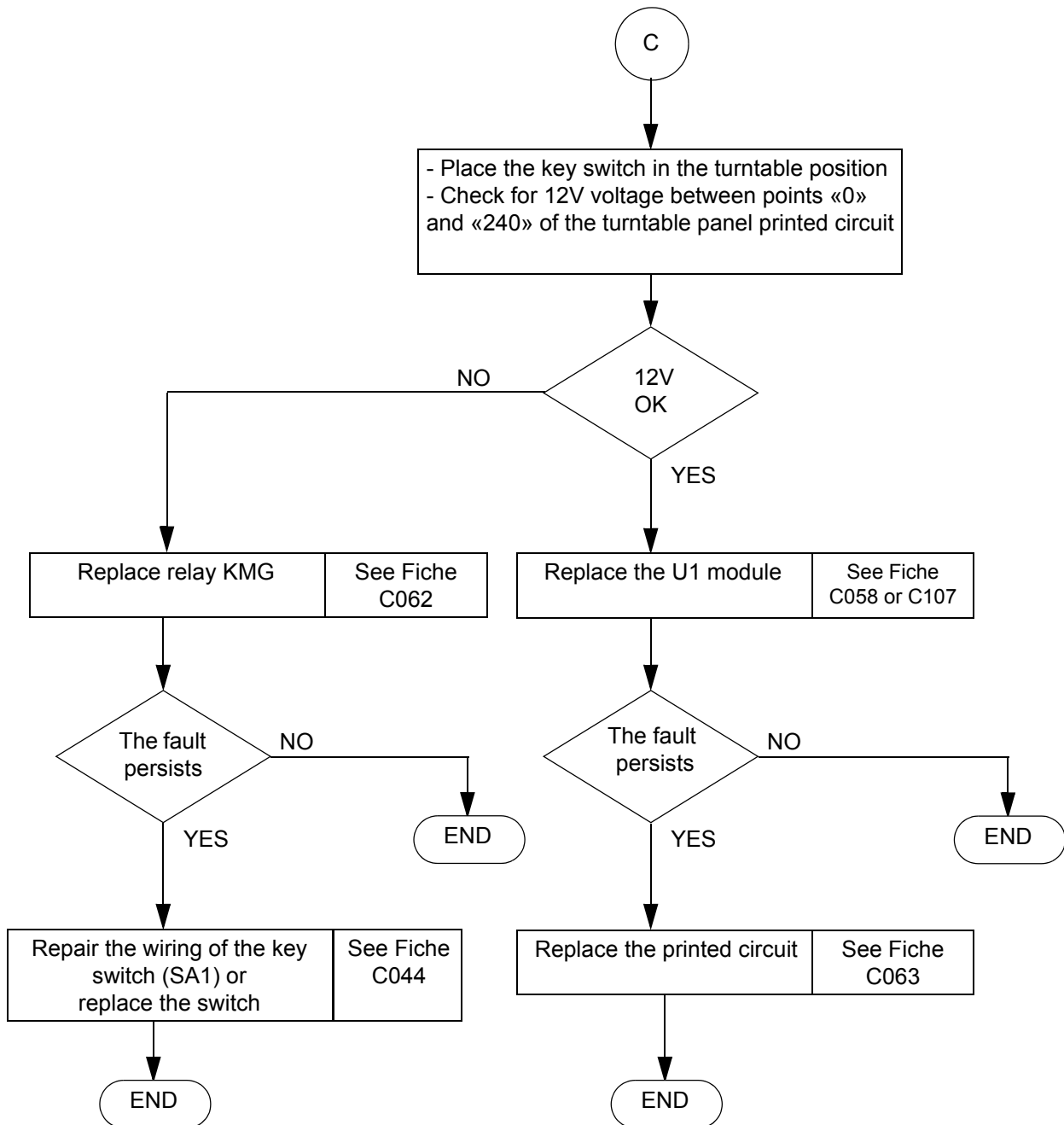

Sheet DP024	BREAKDOWN DETECTION FLOW CHART	Folio 1/2
	NO MOVEMENT AVAILABLE FROM THE PLATFORM CONTROL PANEL	

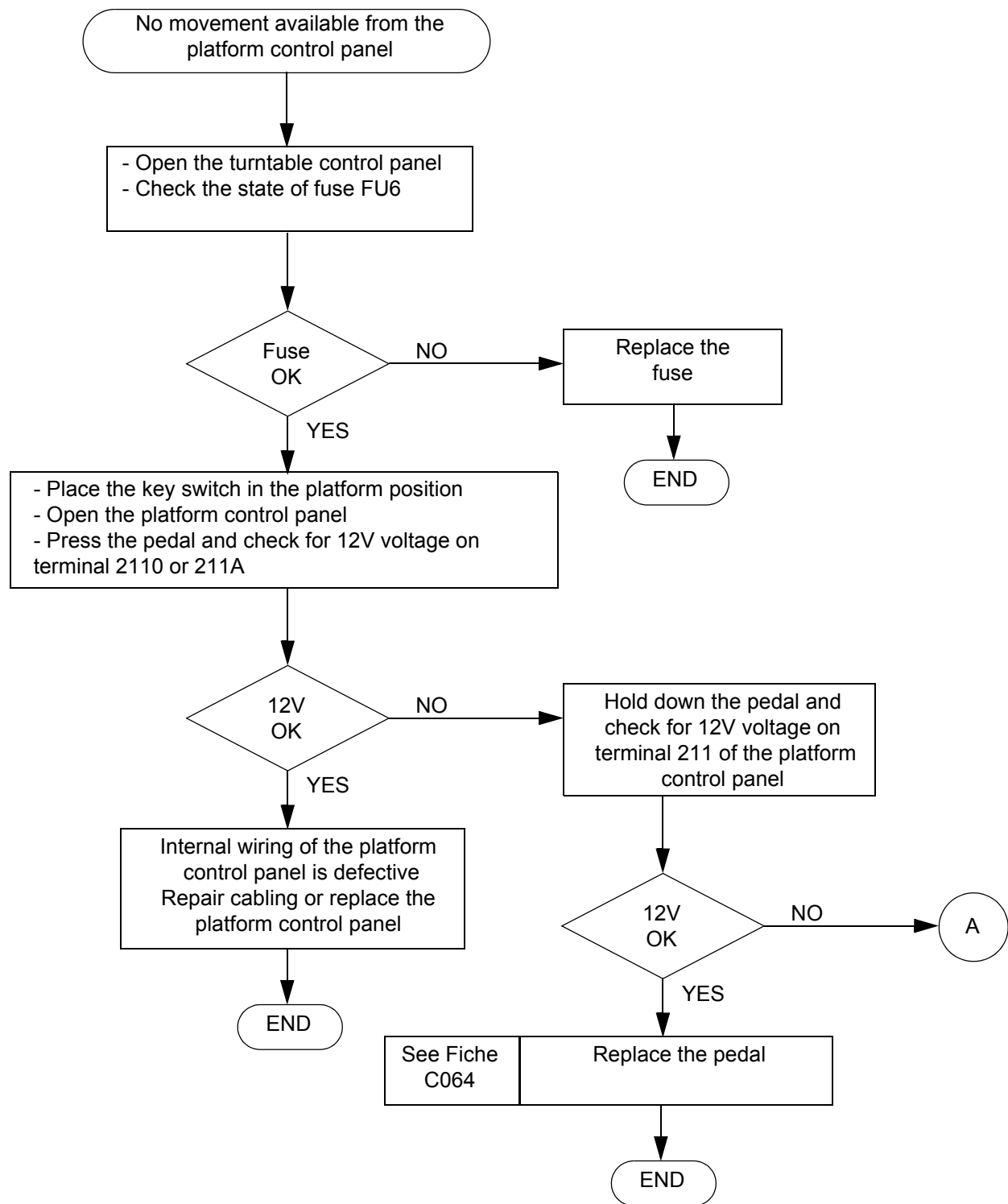

Sheet DP024	BREAKDOWN DETECTION FLOW CHART	Folio 2/2
	NO MOVEMENT AVAILABLE FROM THE PLATFORM CONTROL PANEL	

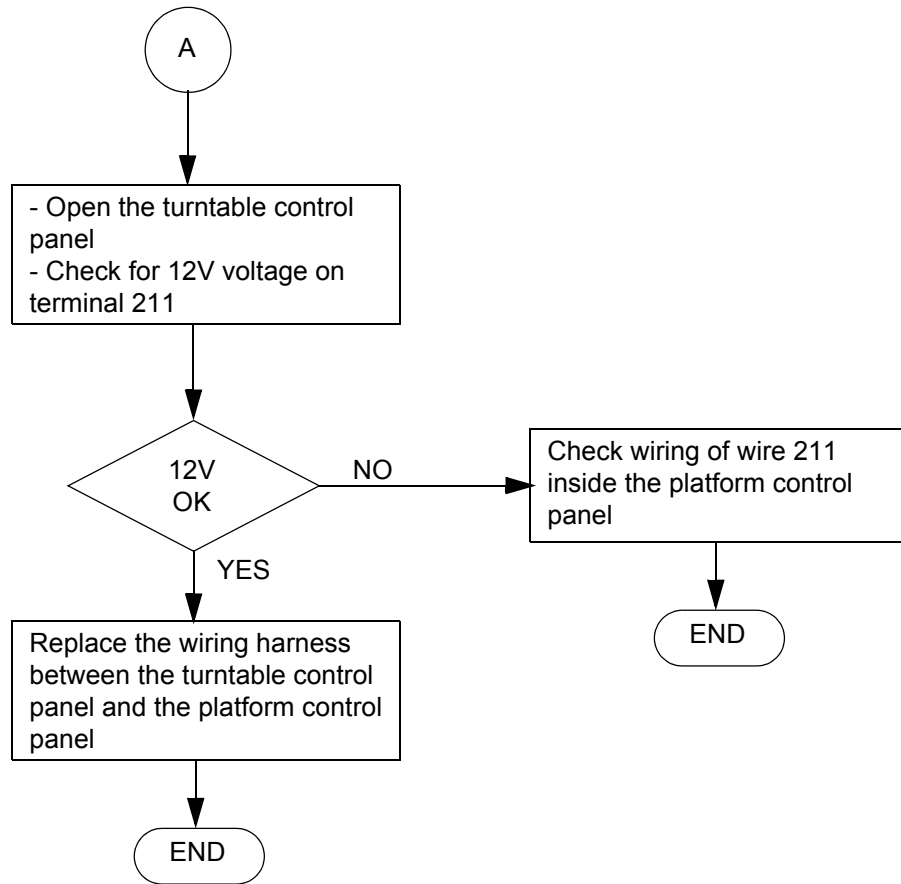

Sheet DP025	BREAKDOWN DETECTION FLOW CHART	Folio 1/2
	NOISY HYDRAULIC PUMP	

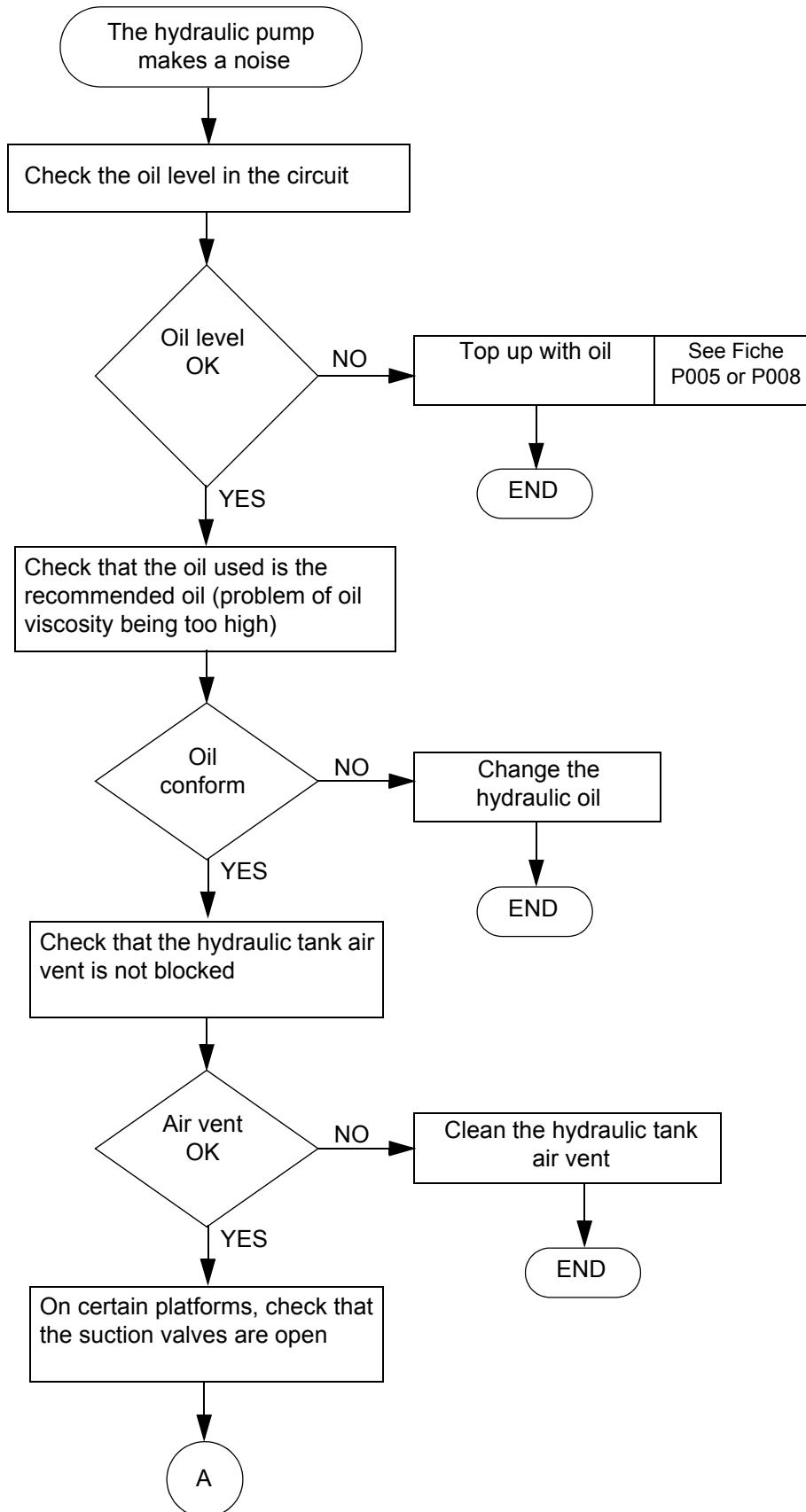

Sheet DP025	BREAKDOWN DETECTION FLOW CHART	Folio 2/2
	NOISY HYDRAULIC PUMP	

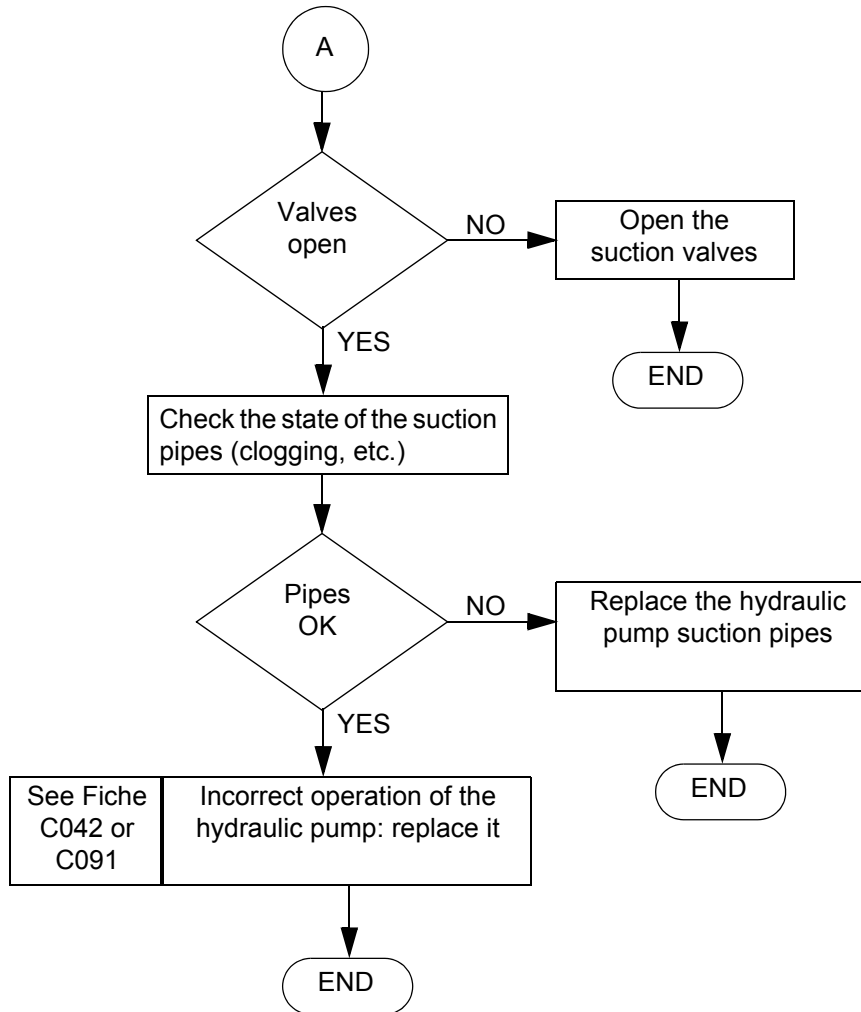

Sheet DP028	BREAKDOWN DETECTION FLOW CHART	Folio 1/5
	NO JIB MOVEMENT (UP AND / OR DOWN) FROM THE PLATFORM (OR TURNTABLE) CONTROL PANEL	

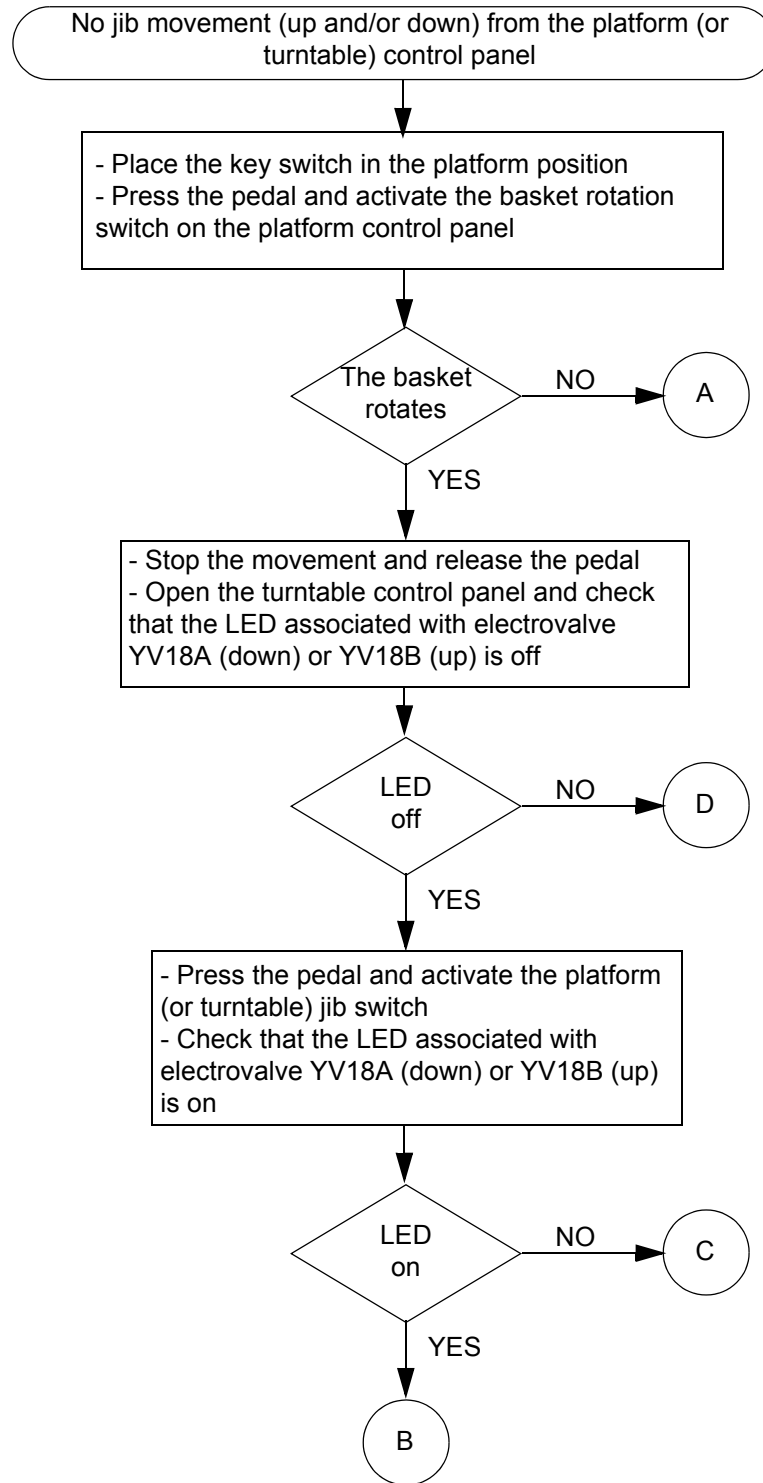

Sheet DP028	BREAKDOWN DETECTION FLOW CHART	Folio 2/5
	NO JIB MOVEMENT (UP AND / OR DOWN) FROM THE PLATFORM (OR TURNTABLE) CONTROL PANEL	

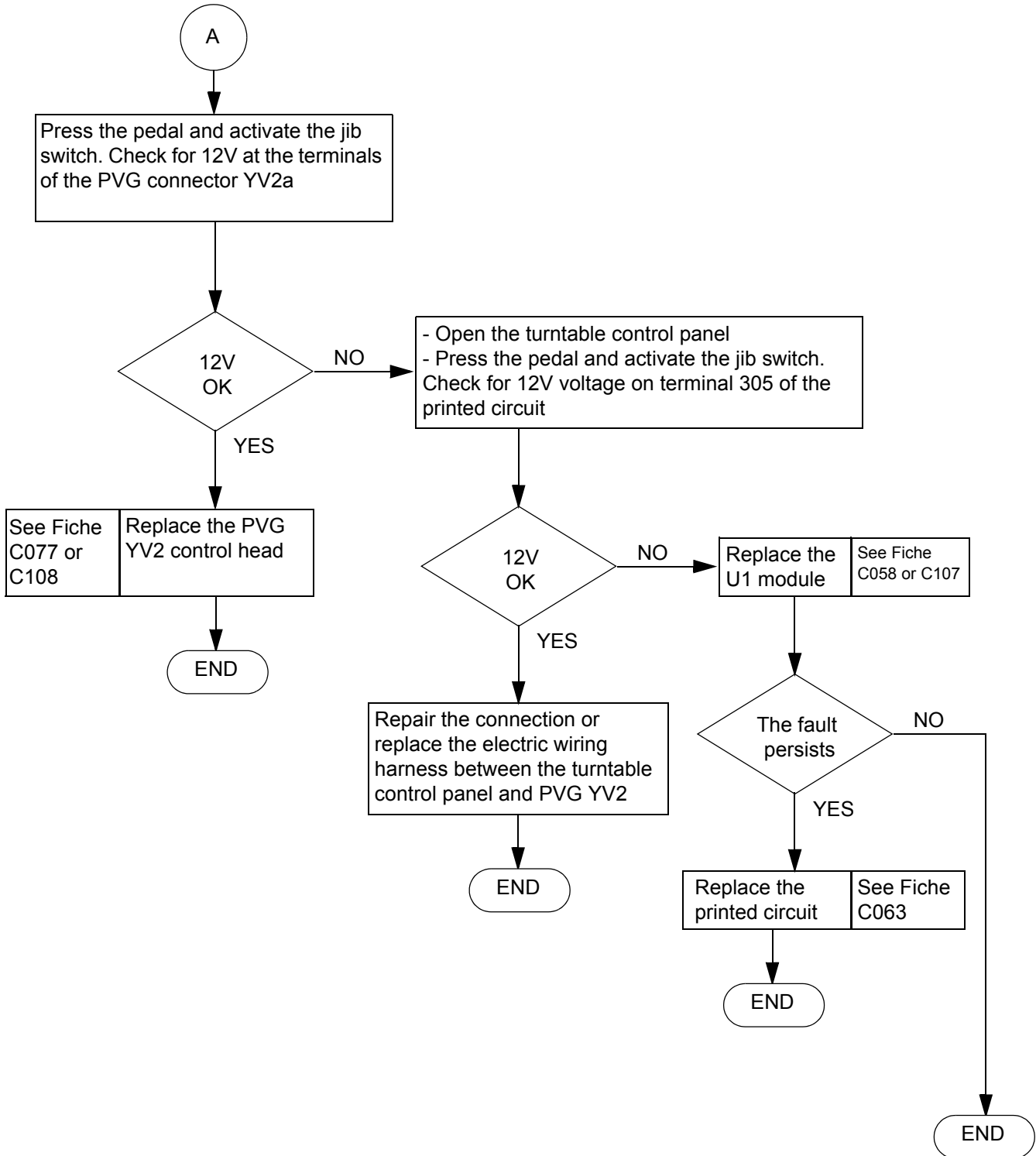

Sheet DP028	BREAKDOWN DETECTION FLOW CHART	Folio 3/5
	NO JIB MOVEMENT (UP AND / OR DOWN) FROM THE PLATFORM (OR TURNTABLE) CONTROL PANEL	

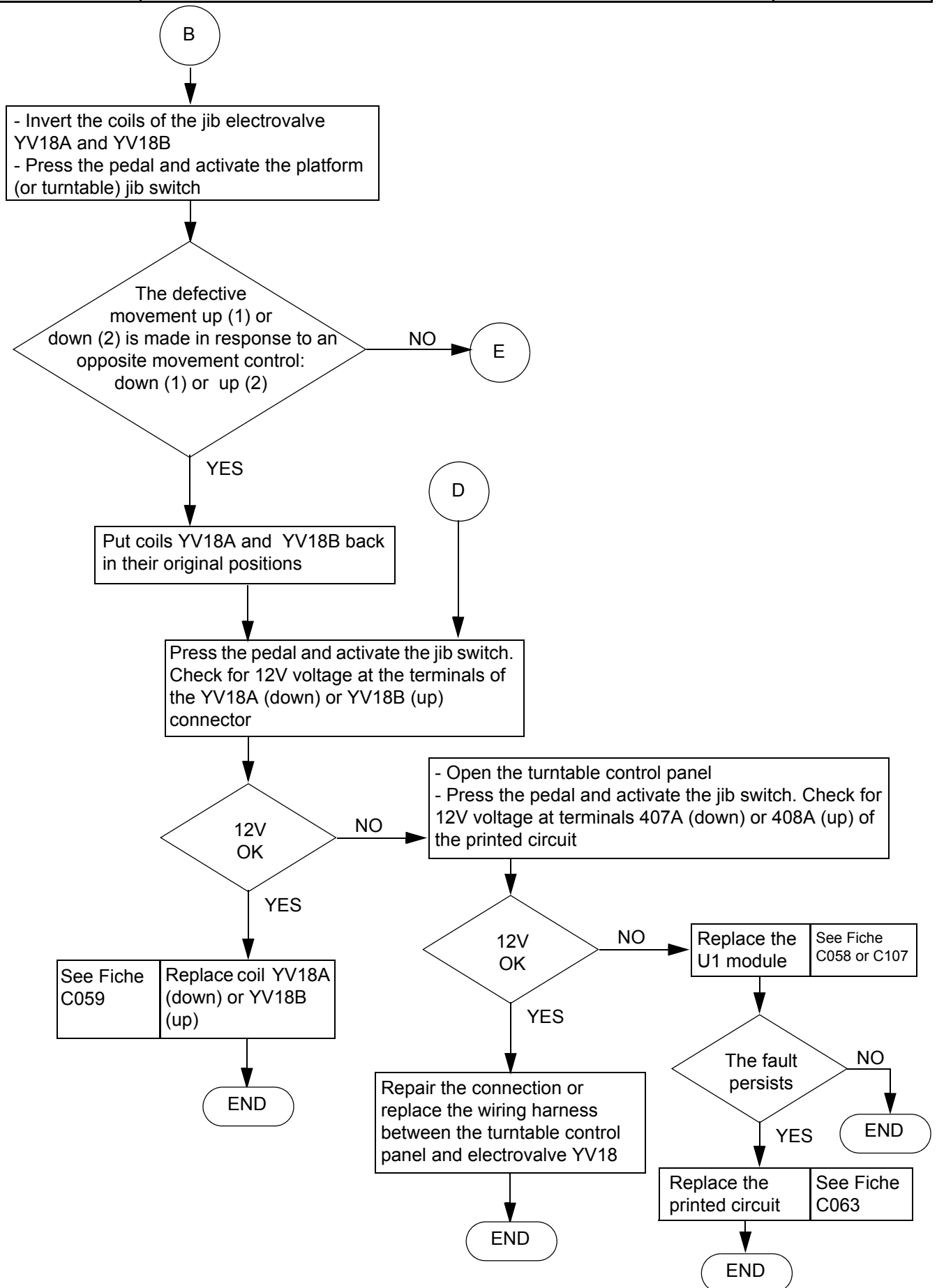

Sheet DP028	BREAKDOWN DETECTION FLOW CHART	Folio 4/5
	NO JIB MOVEMENT (UP AND / OR DOWN) FROM THE PLATFORM (OR TURNTABLE) CONTROL PANEL	

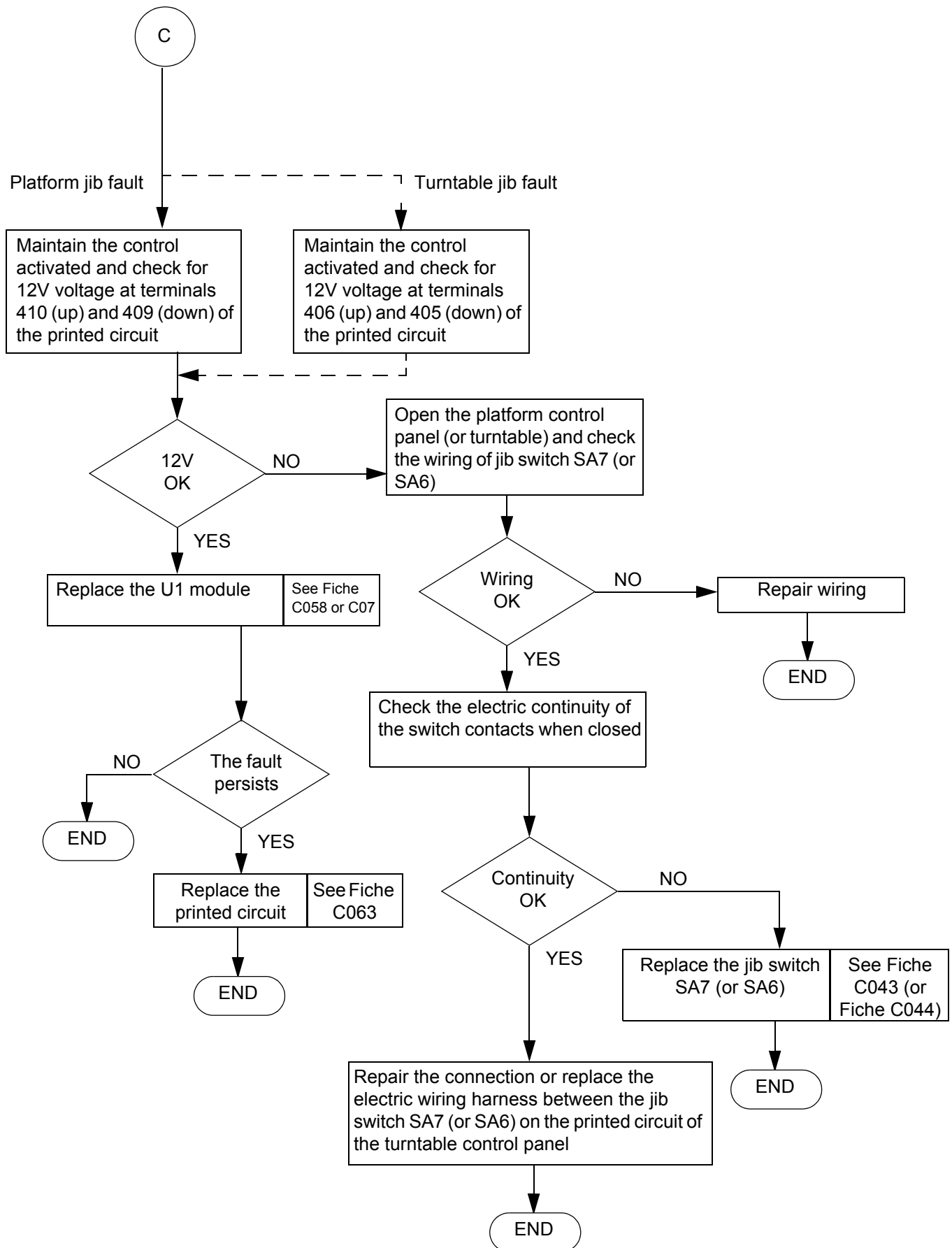

Sheet DP028	BREAKDOWN DETECTION FLOW CHART	Folio 5/5
	NO JIB MOVEMENT (UP AND / OR DOWN) FROM THE PLATFORM (OR TURNTABLE) CONTROL PANEL	

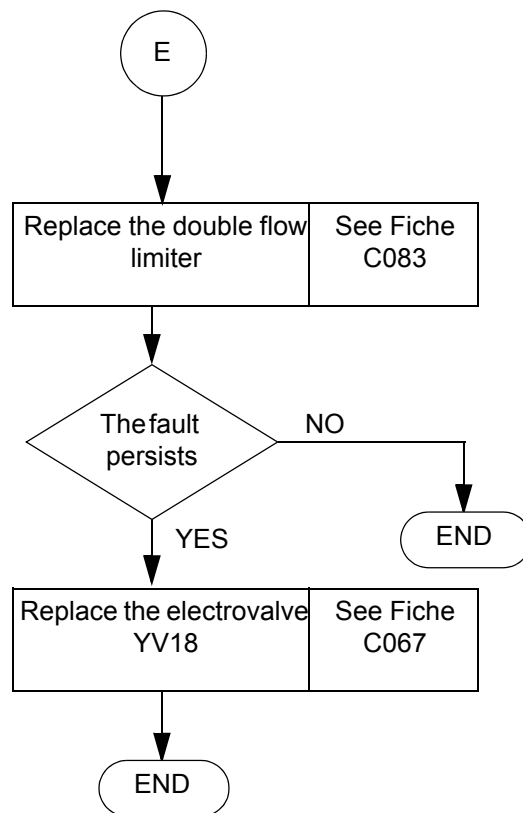

Sheet DP032	BREAKDOWN DETECTION FLOW CHART	Folio 1/4
	NO MACHINE TRAVEL MOVEMENT	

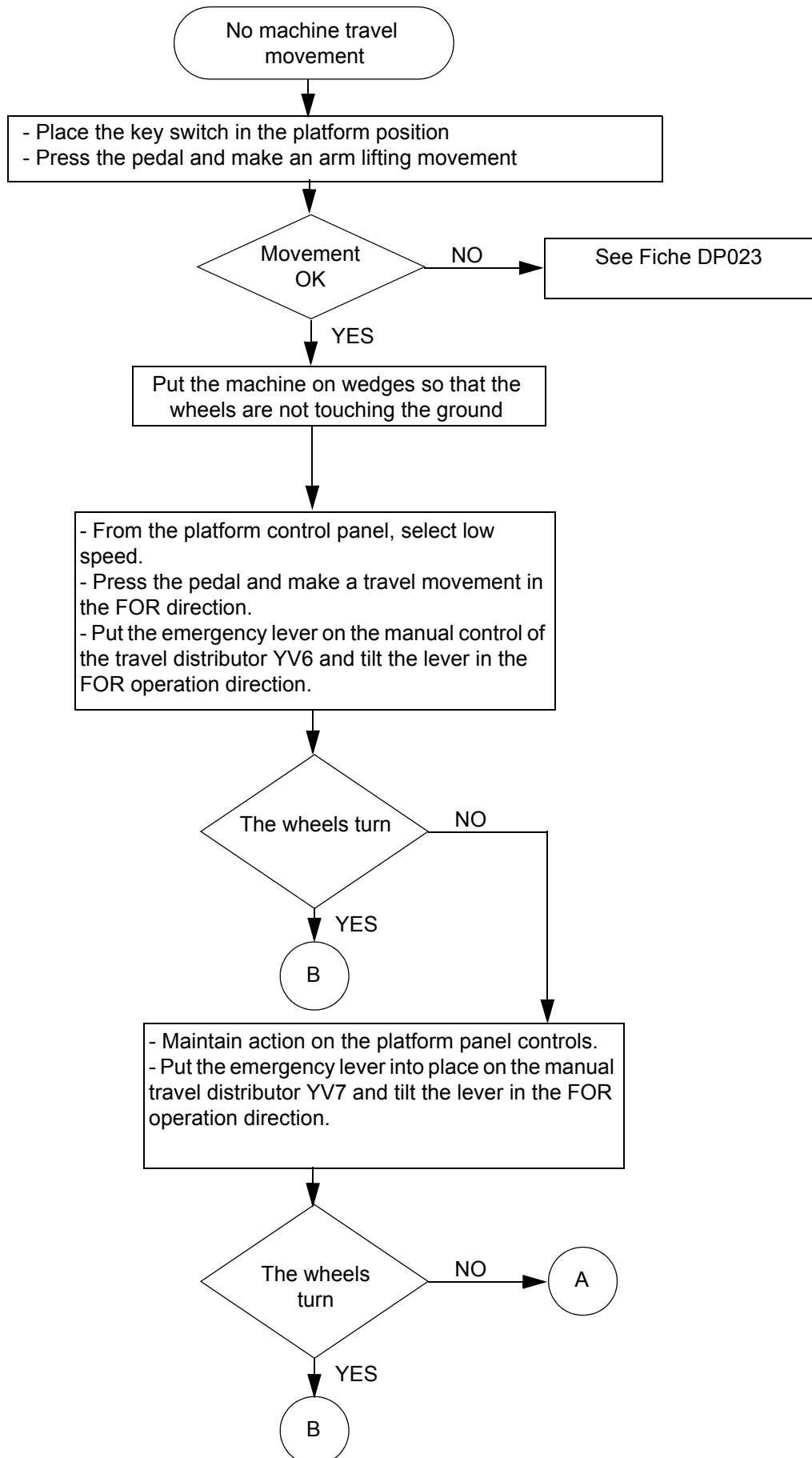

Sheet DP032	BREAKDOWN DETECTION FLOW CHART	Folio 2/4
	NO MACHINE TRAVEL MOVEMENT	

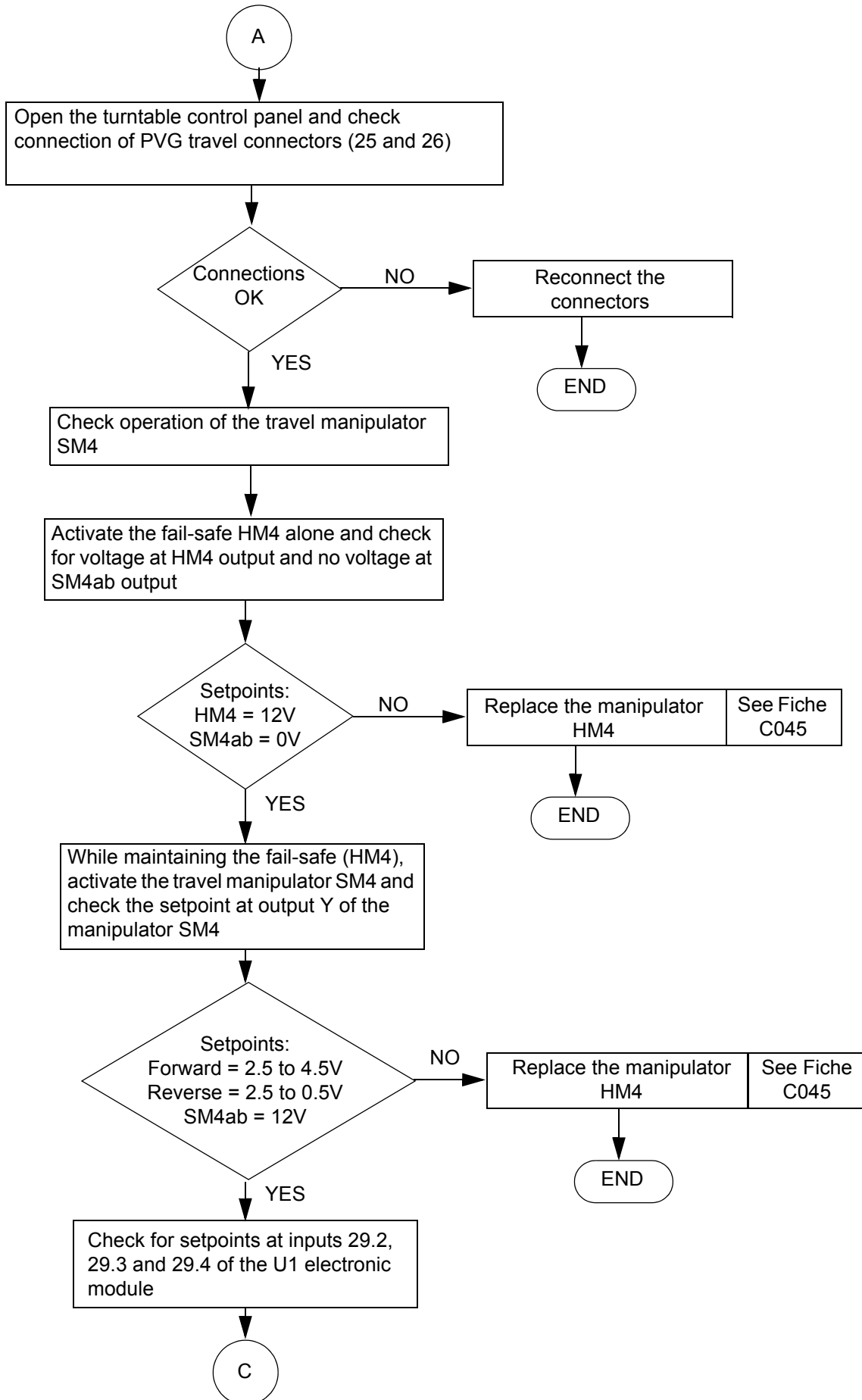

Sheet DP032	BREAKDOWN DETECTION FLOW CHART	Folio 3/4
	NO MACHINE TRAVEL MOVEMENT	

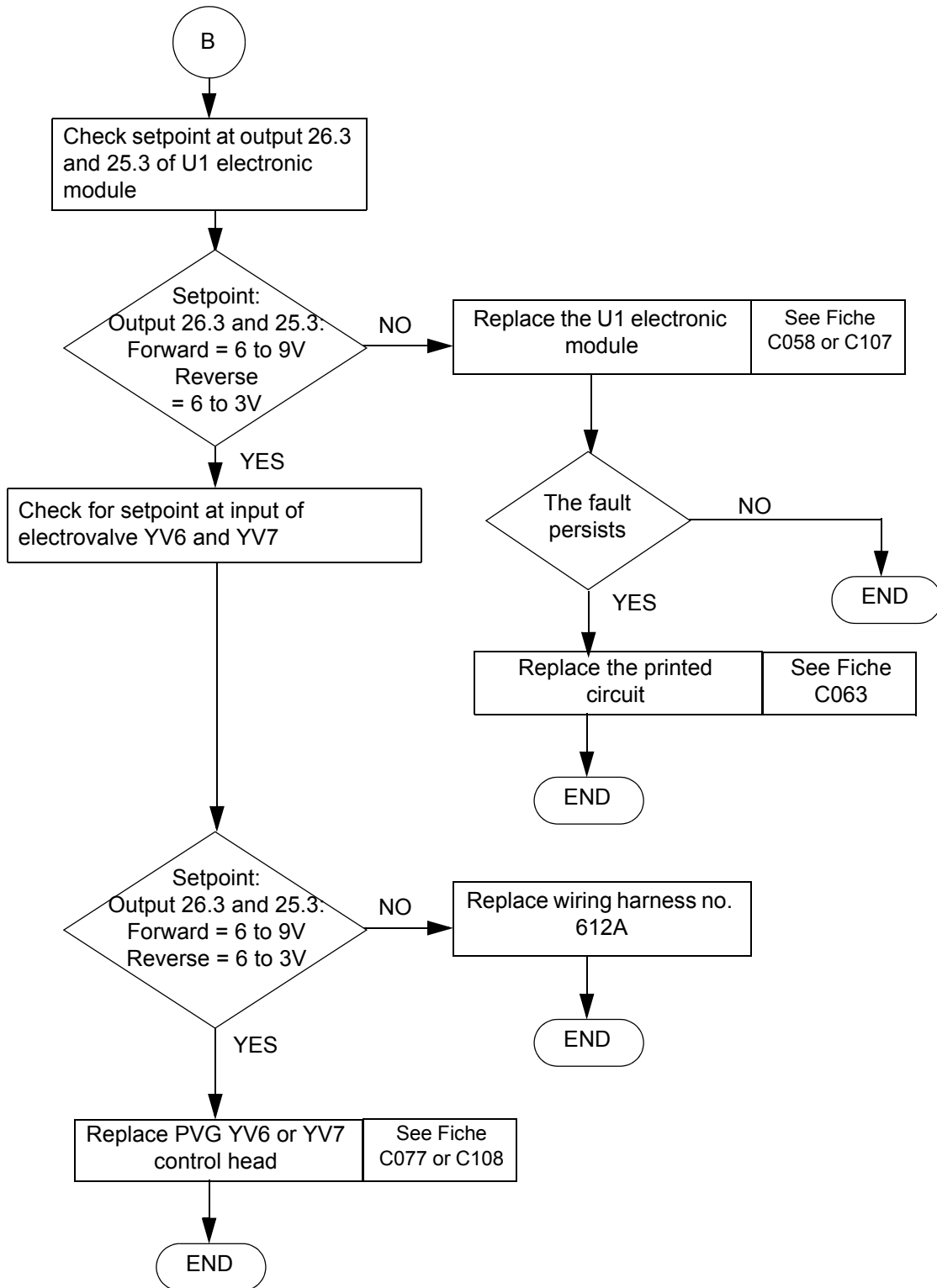

Sheet DP032	BREAKDOWN DETECTION FLOW CHART	Folio 4/4
	NO MACHINE TRAVEL MOVEMENT	

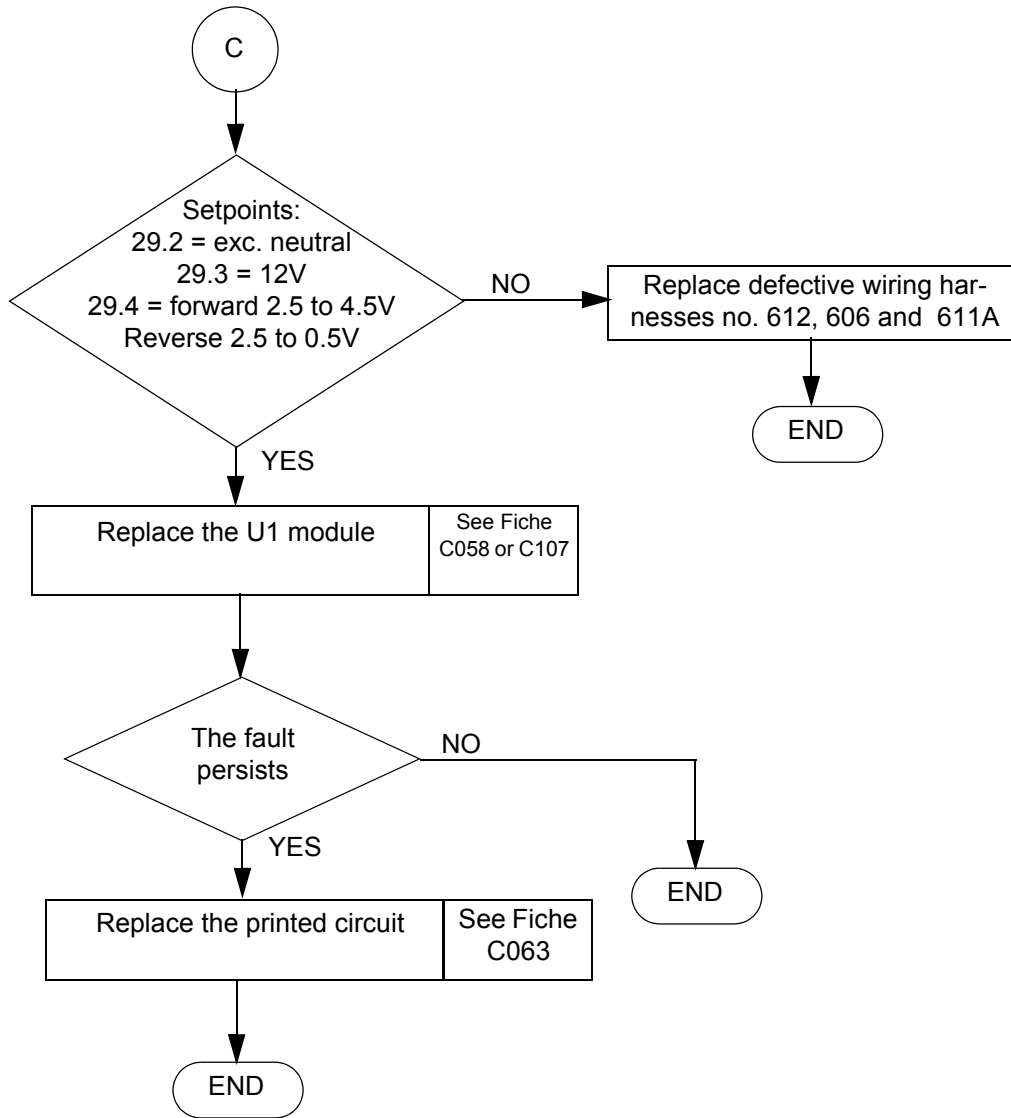

Sheet DP034	BREAKDOWN DETECTION FLOW CHART	Folio 1/4
	MACHINE TRAVEL SPEED DOES NOT CORRESPOND TO THE SELECTOR SPEED	

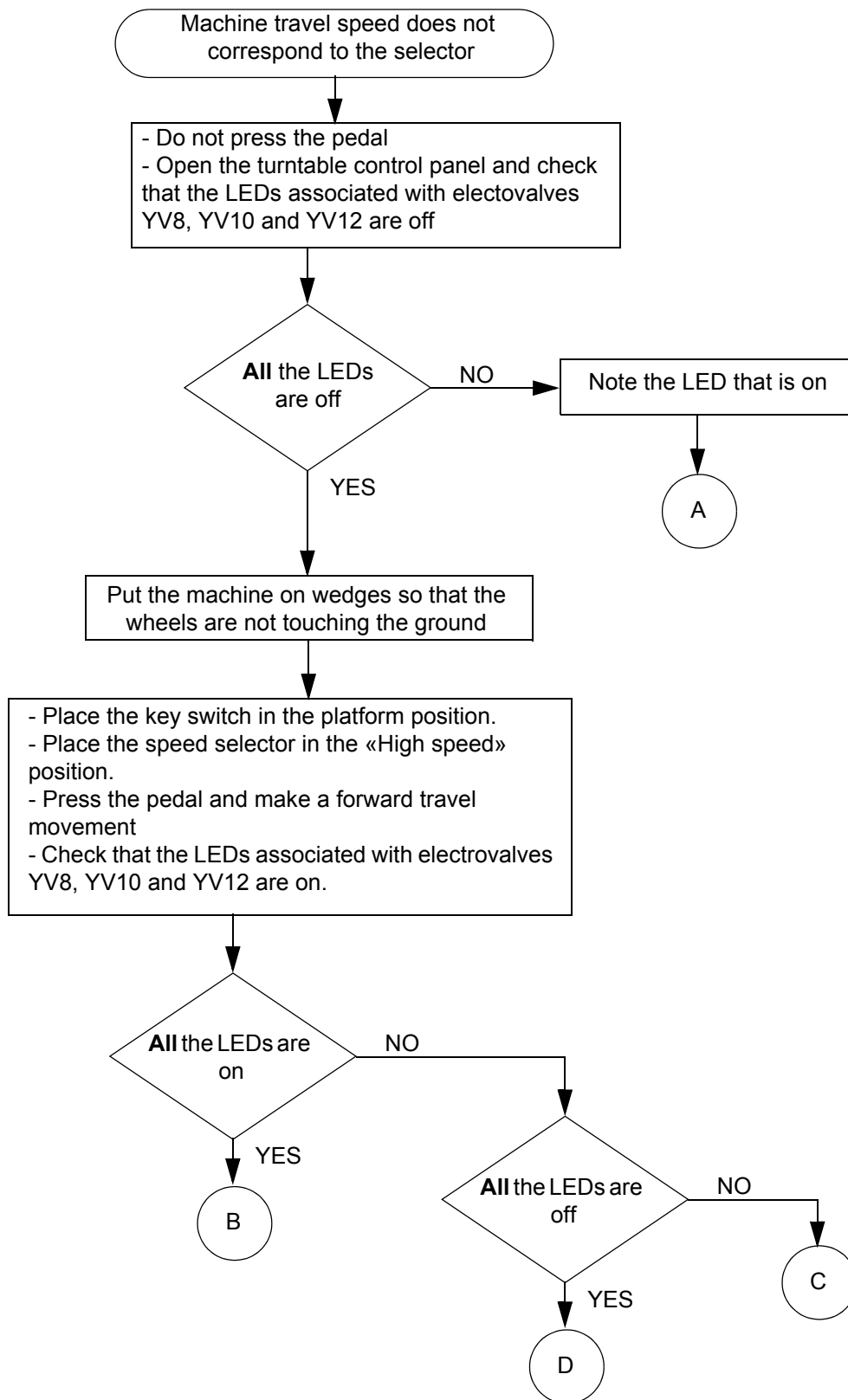

Sheet DP034	BREAKDOWN DETECTION FLOW CHART	Folio 2/4
	MACHINE TRAVEL SPEED DOES NOT CORRESPOND TO THE SELECTOR SPEED	

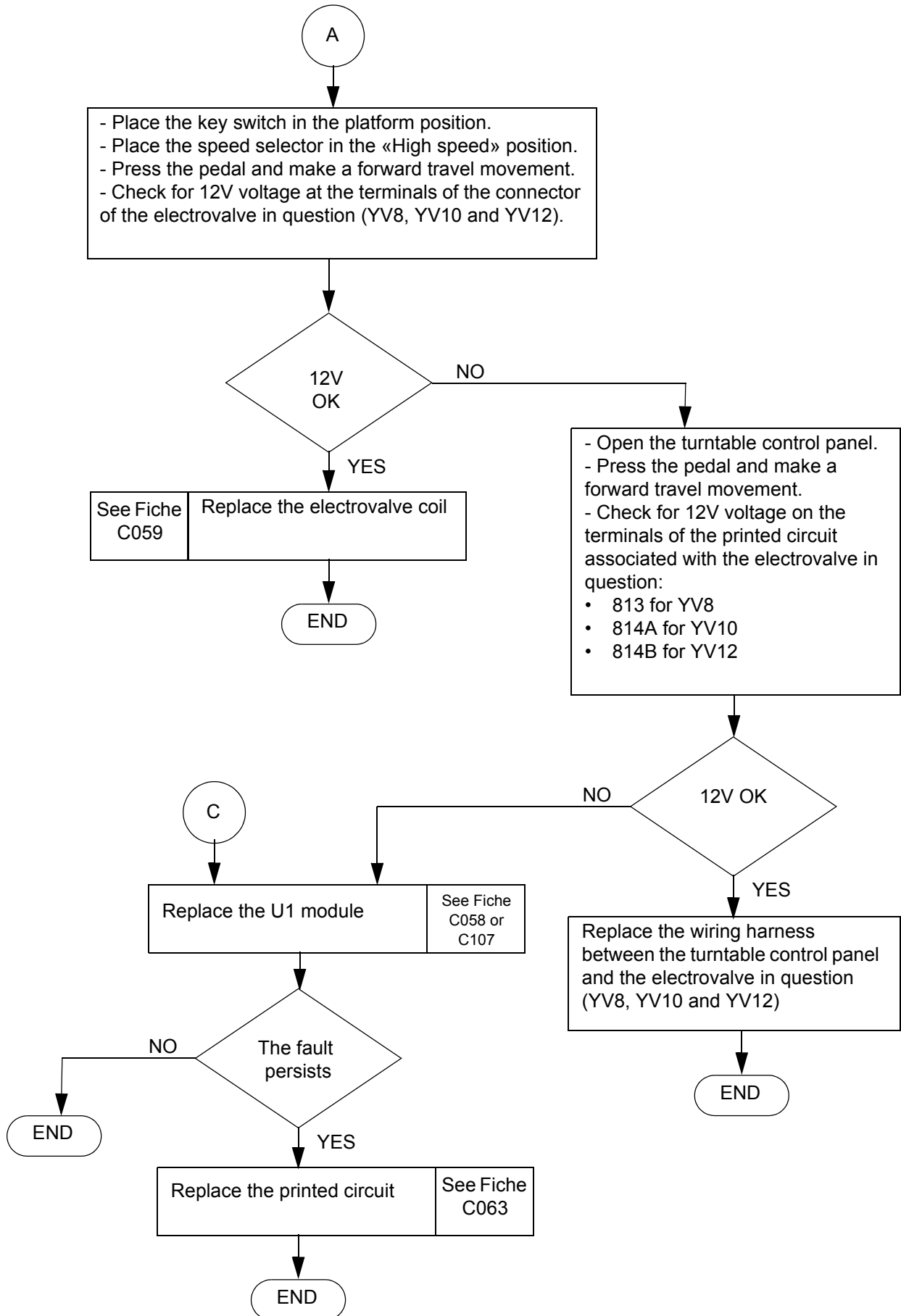

Sheet DP034	BREAKDOWN DETECTION FLOW CHART	Folio 3/4
	MACHINE TRAVEL SPEED DOES NOT CORRESPOND TO THE SELECTOR SPEED	

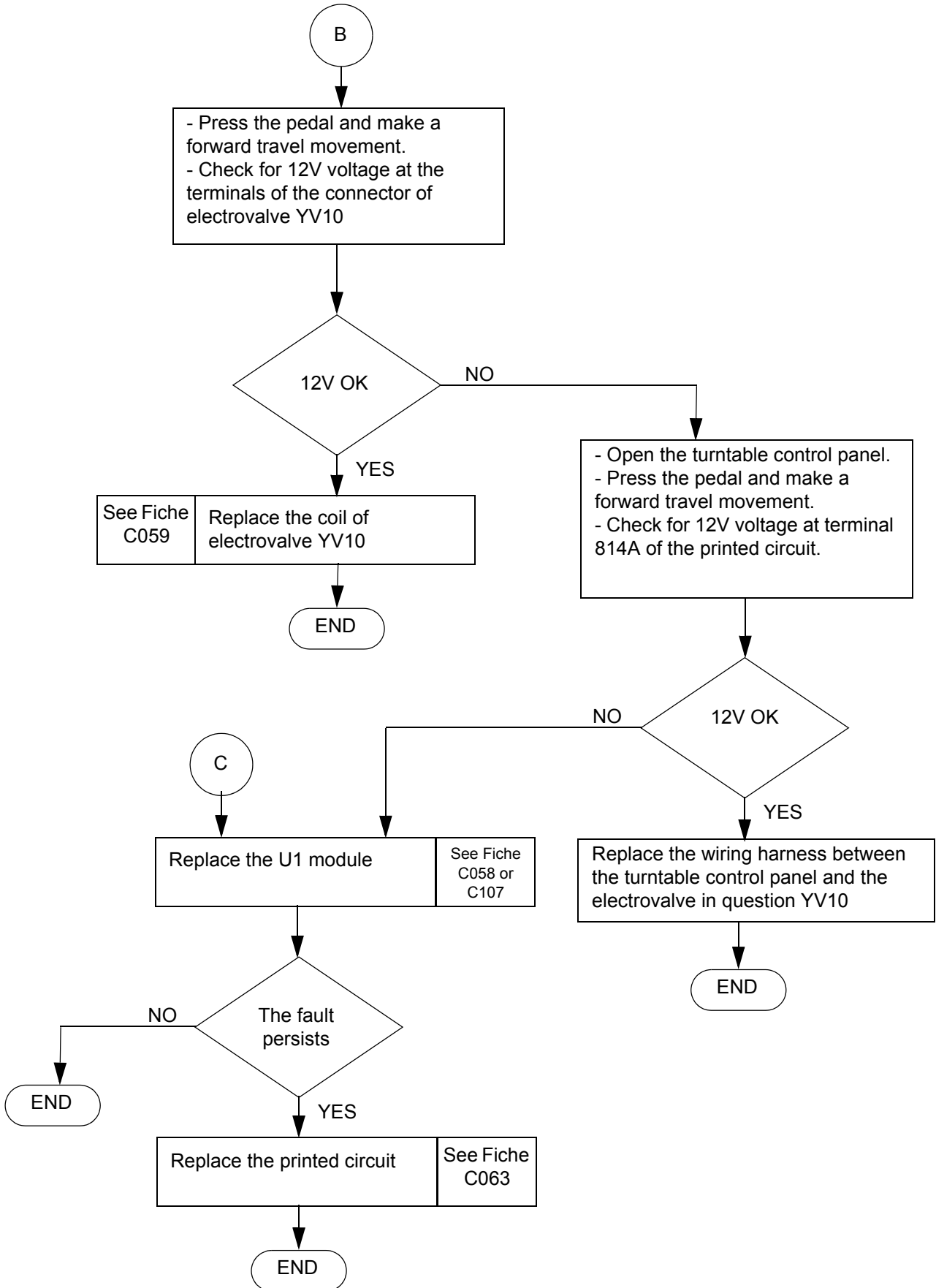

Sheet DP034	BREAKDOWN DETECTION FLOW CHART	Folio 4/4
	MACHINE TRAVEL SPEED DOES NOT CORRESPOND TO THE SELECTOR SPEED	

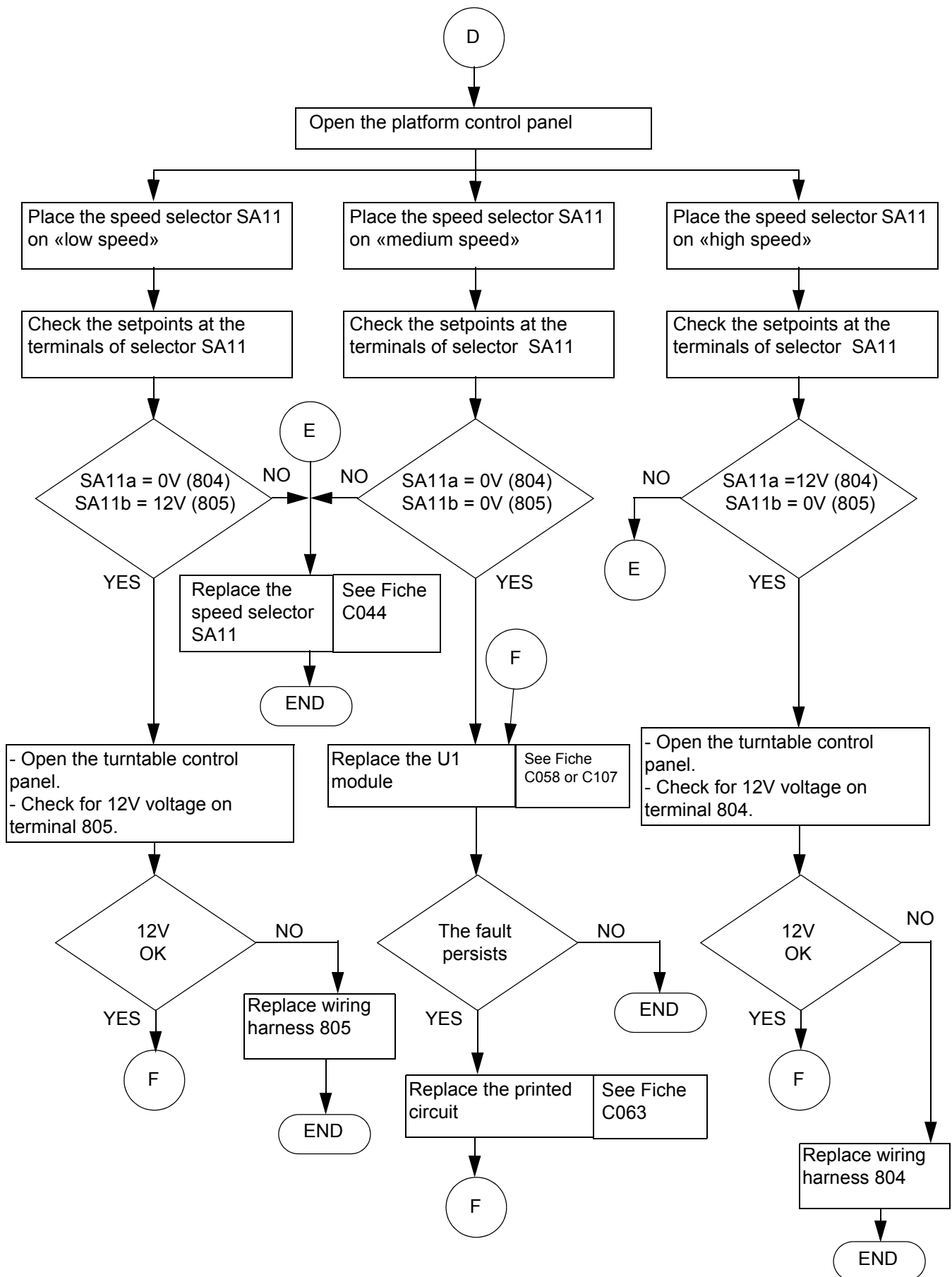

Sheet DP036	BREAKDOWN DETECTION FLOW CHART	Folio 1/3
	NO DIFFERENTIAL BLOCKING WHEN SWITCH SA3 IS ACTIVATED	

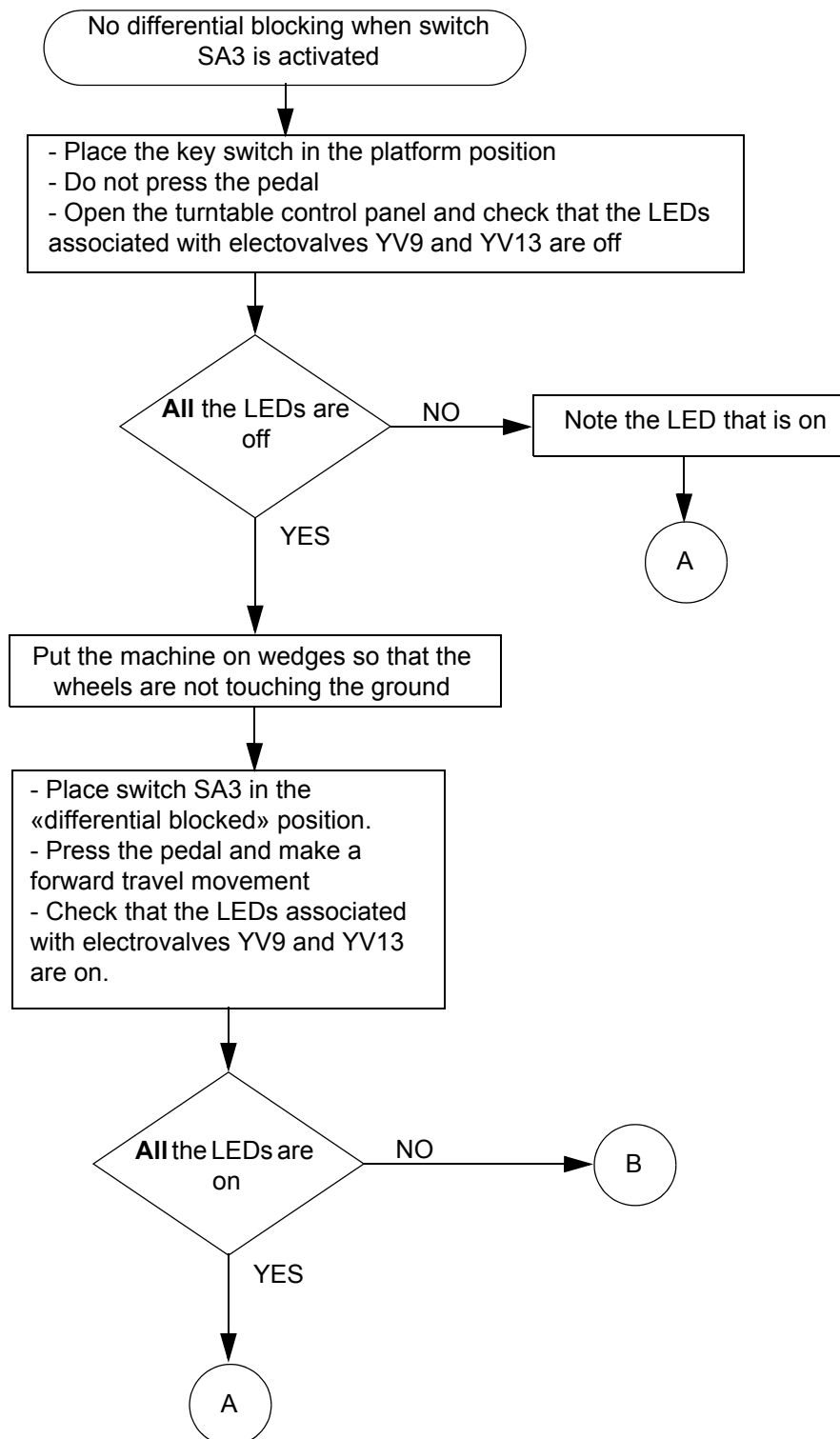

Sheet DP036	BREAKDOWN DETECTION FLOW CHART	Folio 2/3
	NO DIFFERENTIAL BLOCKING WHEN SWITCH SA3 IS ACTIVATED	

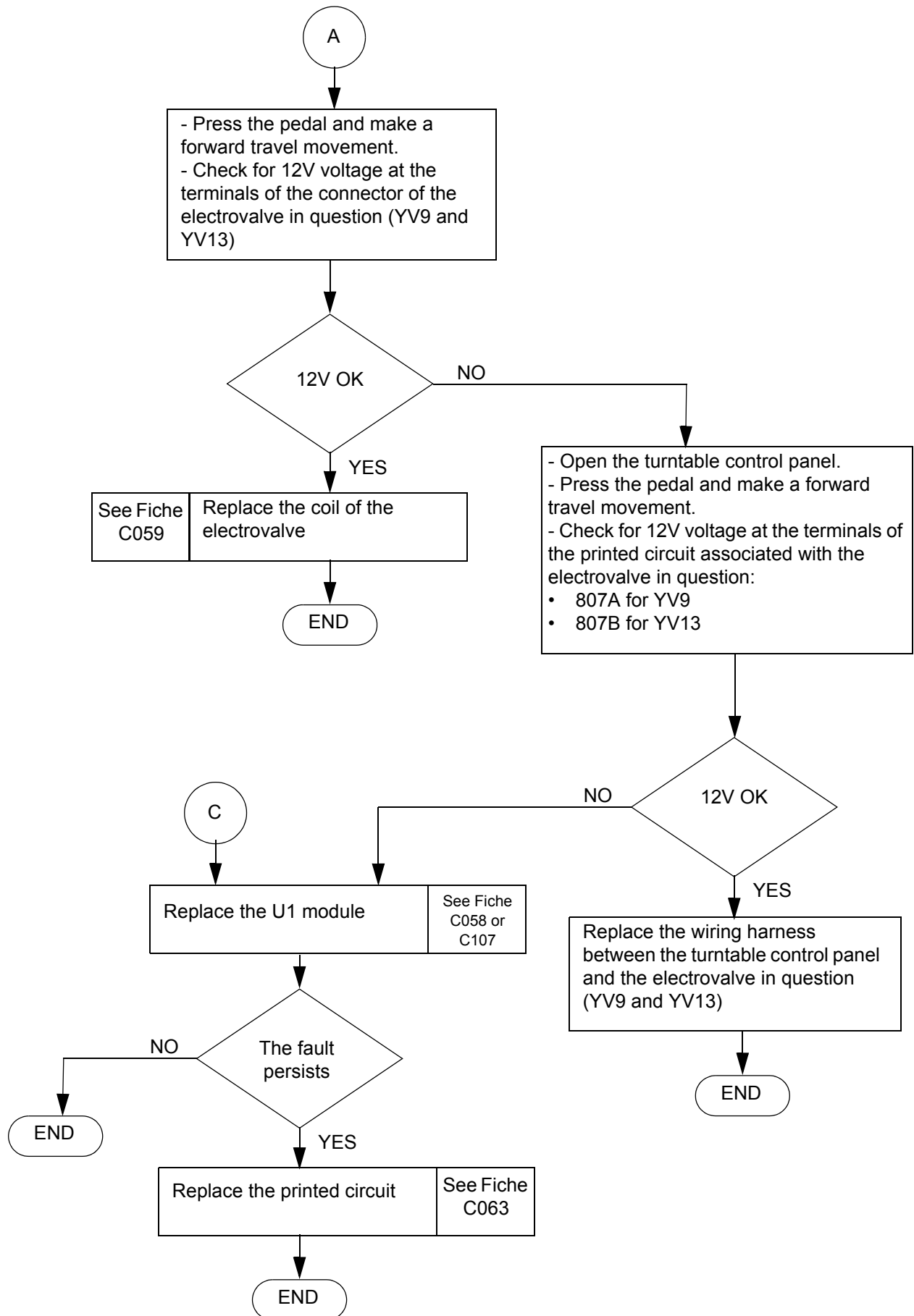

Sheet DP036	BREAKDOWN DETECTION FLOW CHART	Folio 3/3
	NO DIFFERENTIAL BLOCKING WHEN SWITCH SA3 IS ACTIVATED	

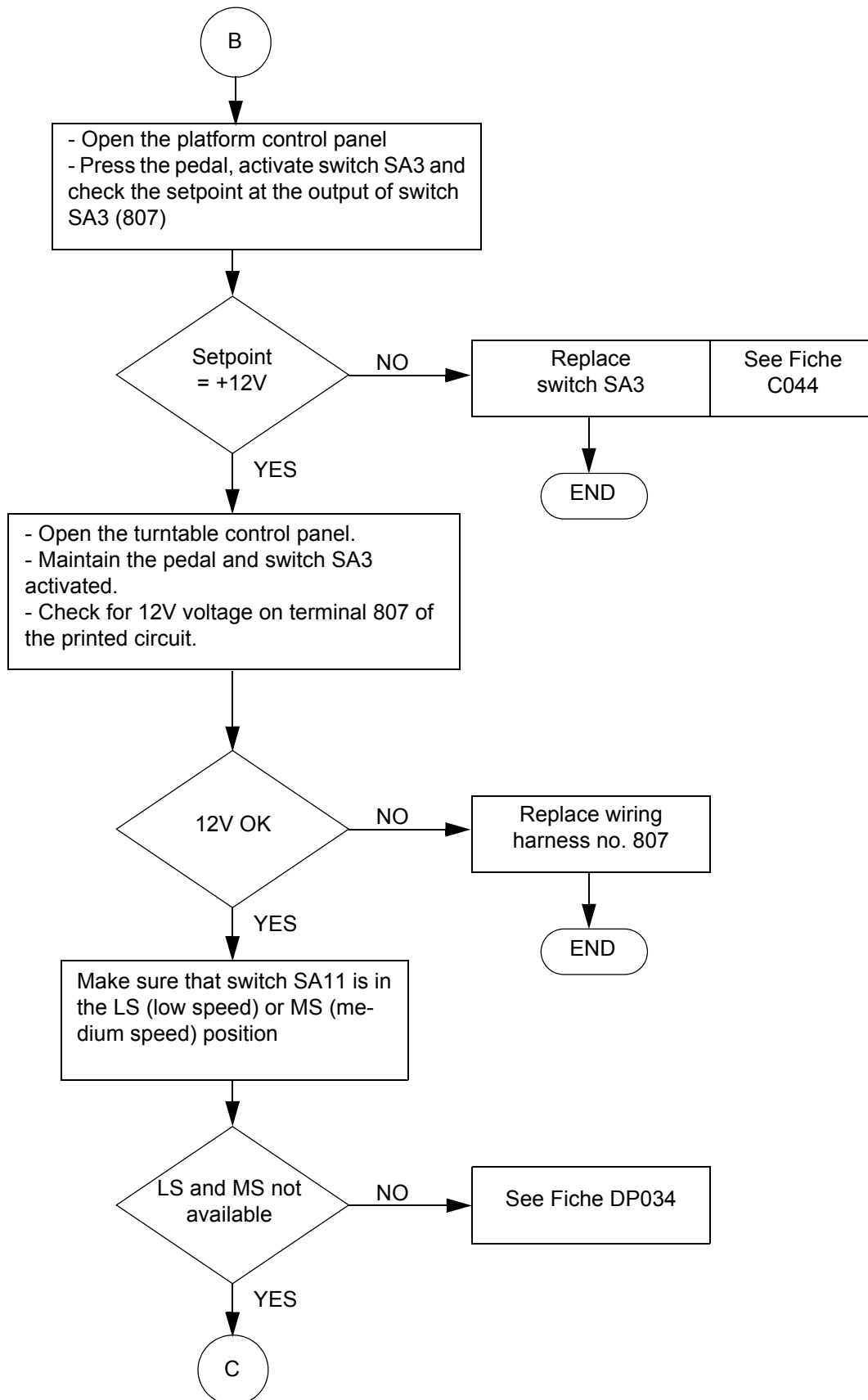

Sheet DP041	BREAKDOWN DETECTION FLOW CHART	Folio 1/1
	THE MOTOR STARTS THEN STOPS AFTER 5 SECS	

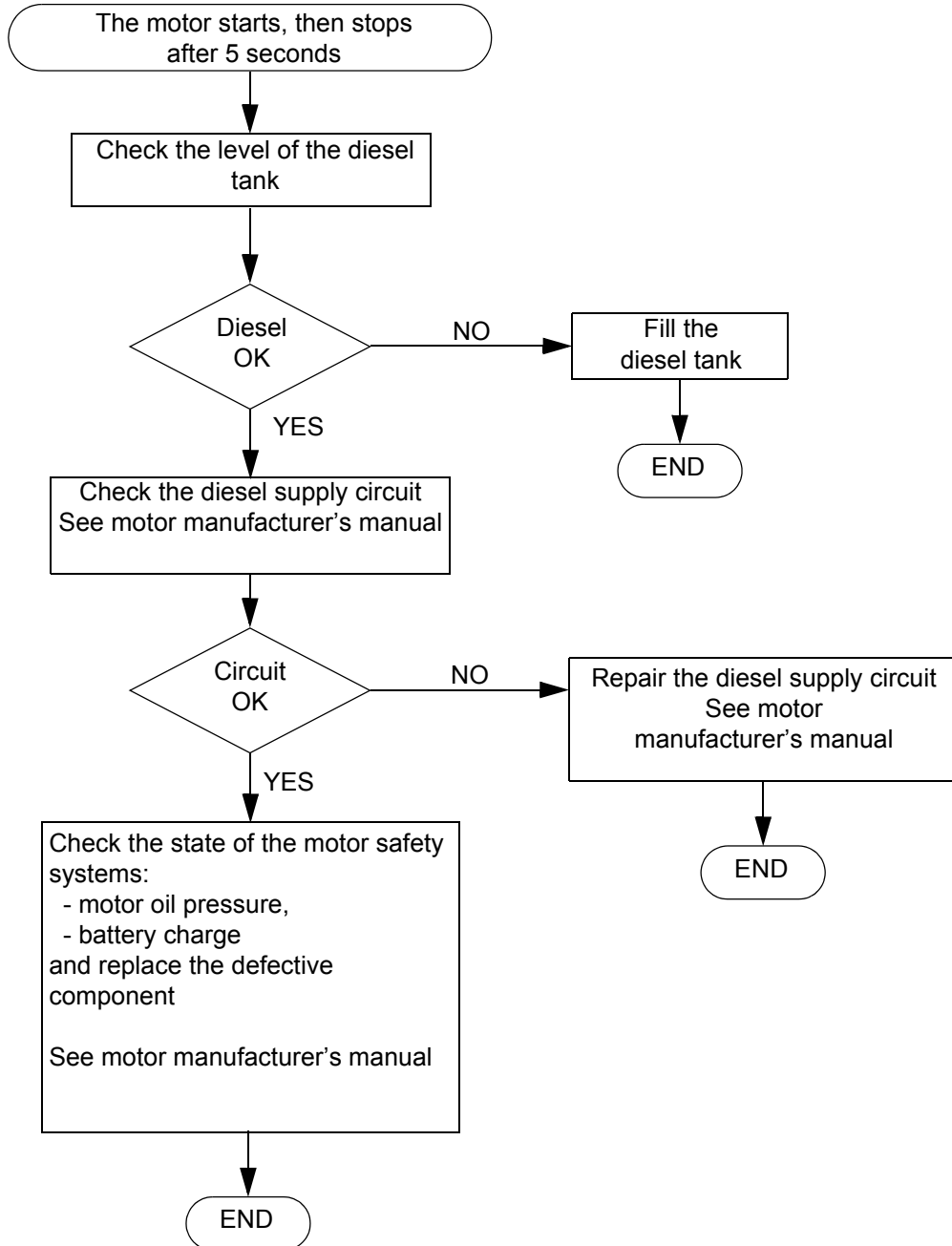

Sheet DP042	BREAKDOWN DETECTION FLOW CHART	Folio 1/4
	NO TURNTABLE ROTATION MOVEMENT (RIGHT AND/OR LEFT) FROM THE PLATFORM (OR TURNTABLE) CONTROL PANEL	

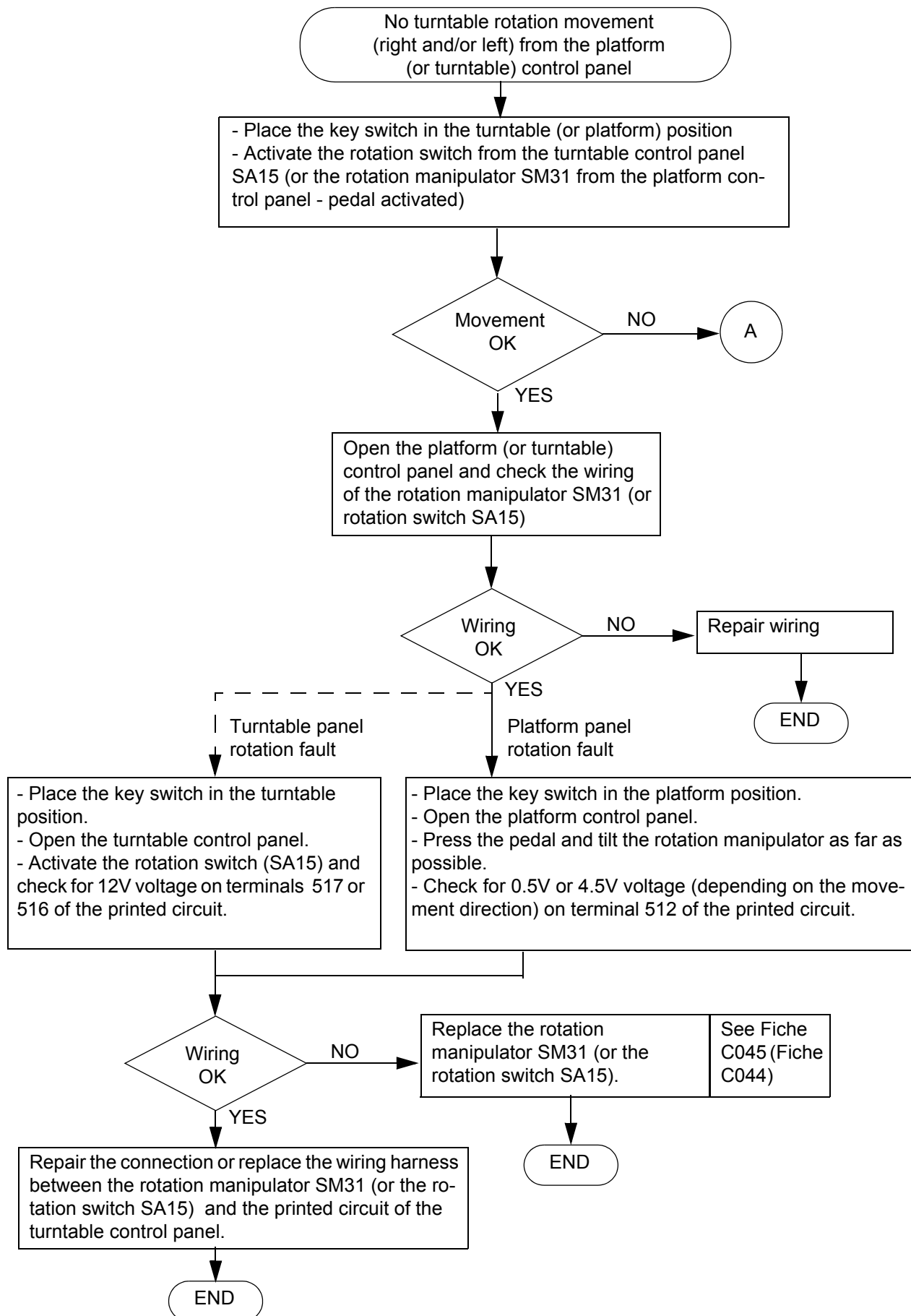

Sheet DP042	BREAKDOWN DETECTION FLOW CHART	Folio 2/4
	NO TURNTABLE ROTATION MOVEMENT (RIGHT AND/OR LEFT) FROM THE PLATFORM (OR TURNTABLE) CONTROL PANEL	

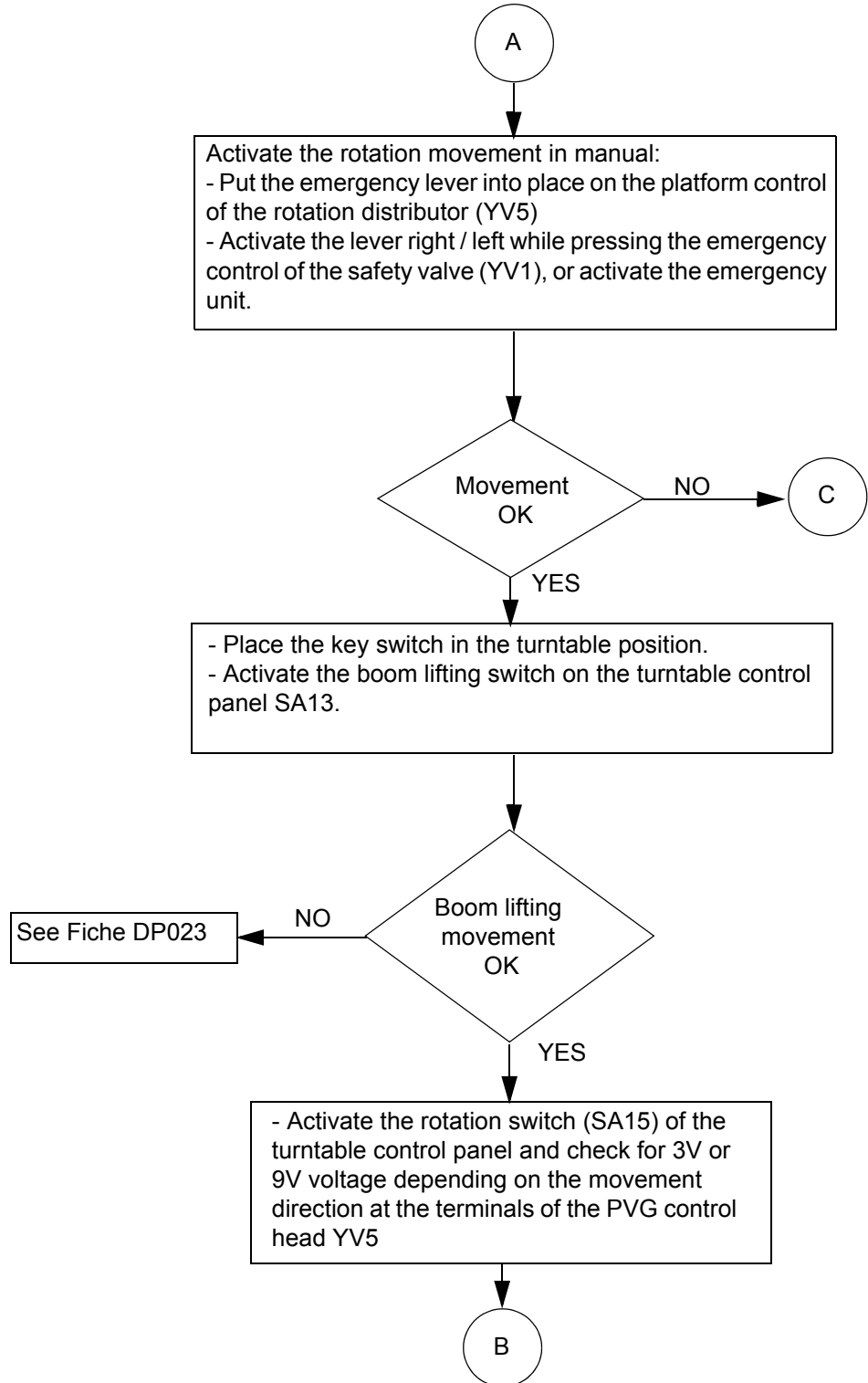

Sheet DP042	BREAKDOWN DETECTION FLOW CHART	Folio 3/4
	NO TURNTABLE ROTATION MOVEMENT (RIGHT AND/OR LEFT) FROM THE PLATFORM (OR TURNTABLE) CONTROL PANEL	

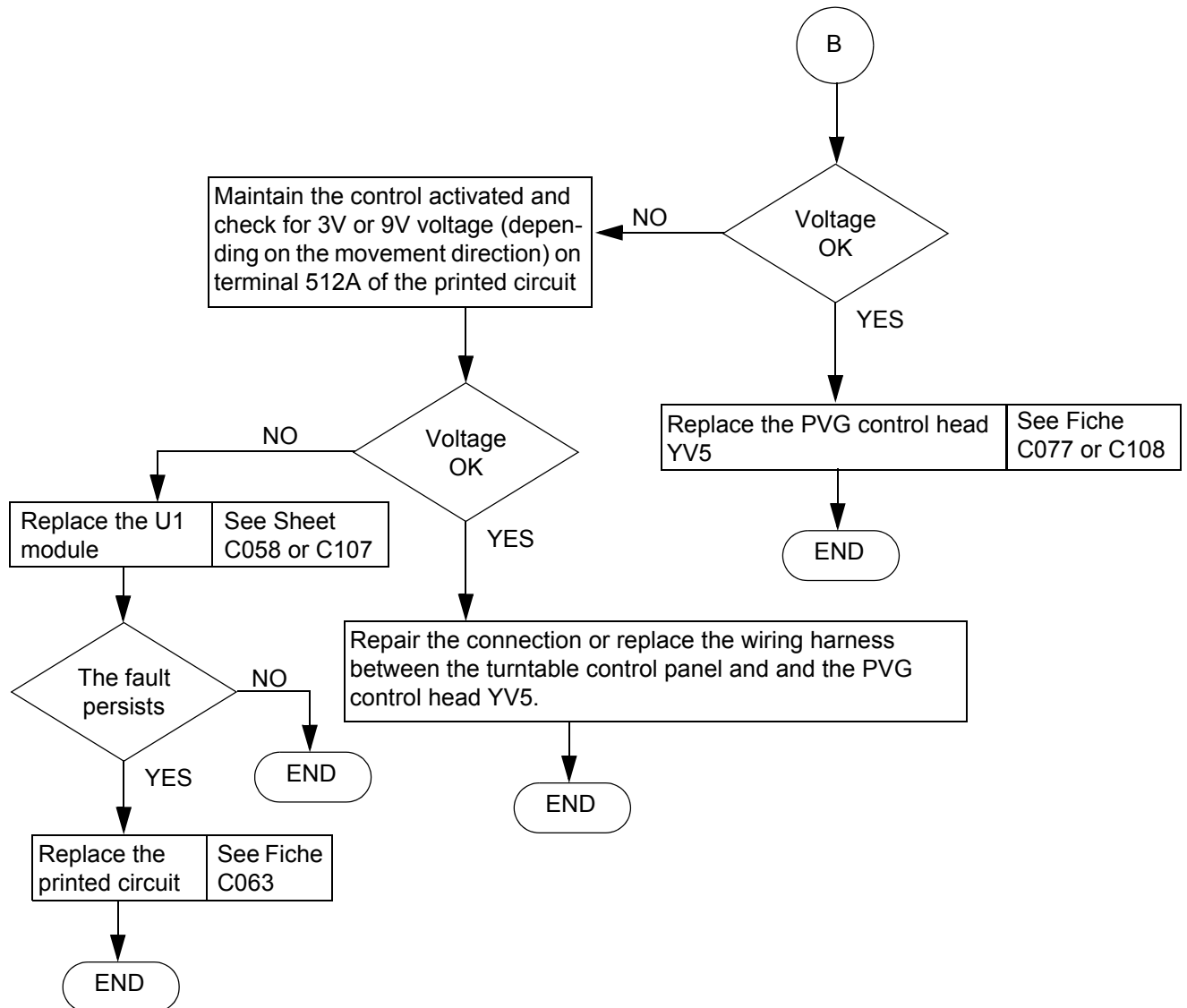

Sheet DP042	BREAKDOWN DETECTION FLOW CHART	Folio 4/4
	NO TURNTABLE ROTATION MOVEMENT (RIGHT AND/OR LEFT) FROM THE PLATFORM (OR TURNTABLE) CONTROL PANEL	

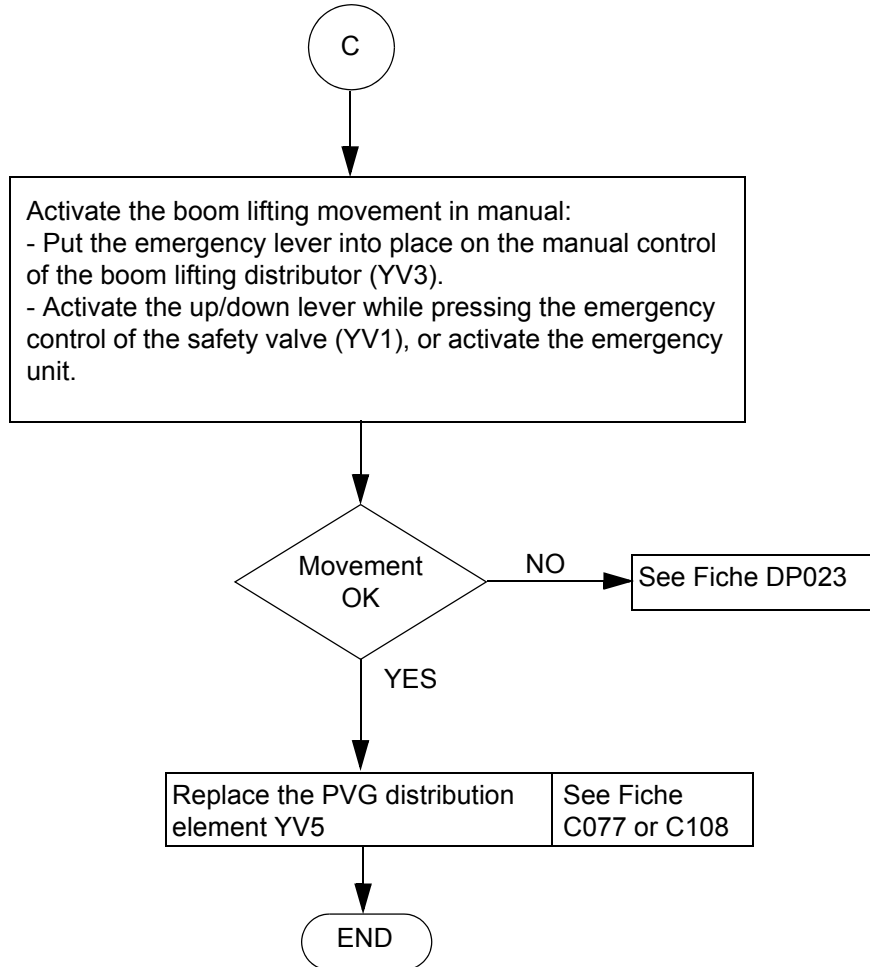

Sheet DP050	BREAKDOWN DETECTION FLOW CHART	Folio 1/5
	NO COMPENSATION MOVEMENT (UP AND/OR DOWN)	

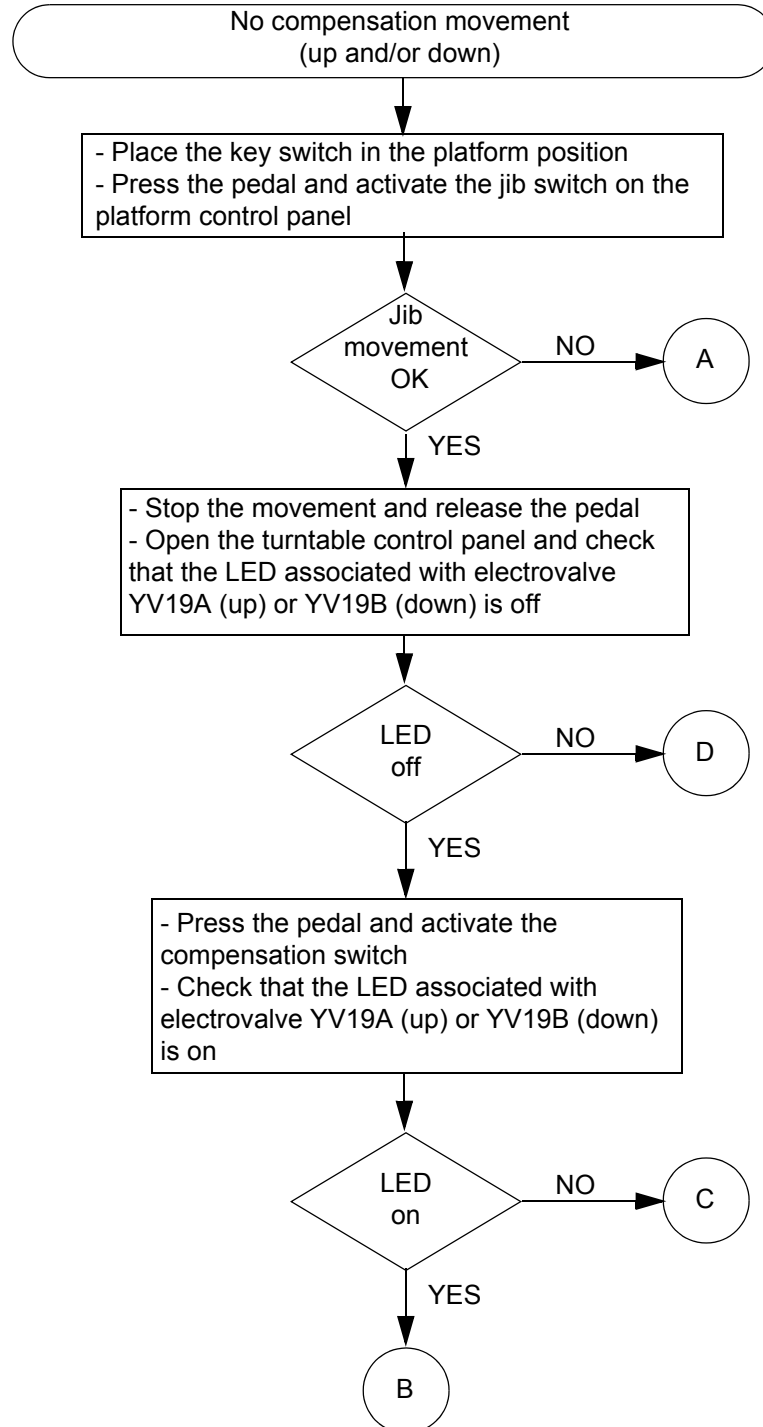

Sheet DP050	BREAKDOWN DETECTION FLOW CHART	Folio 2/5
	NO COMPENSATION MOVEMENT (UP AND/OR DOWN)	

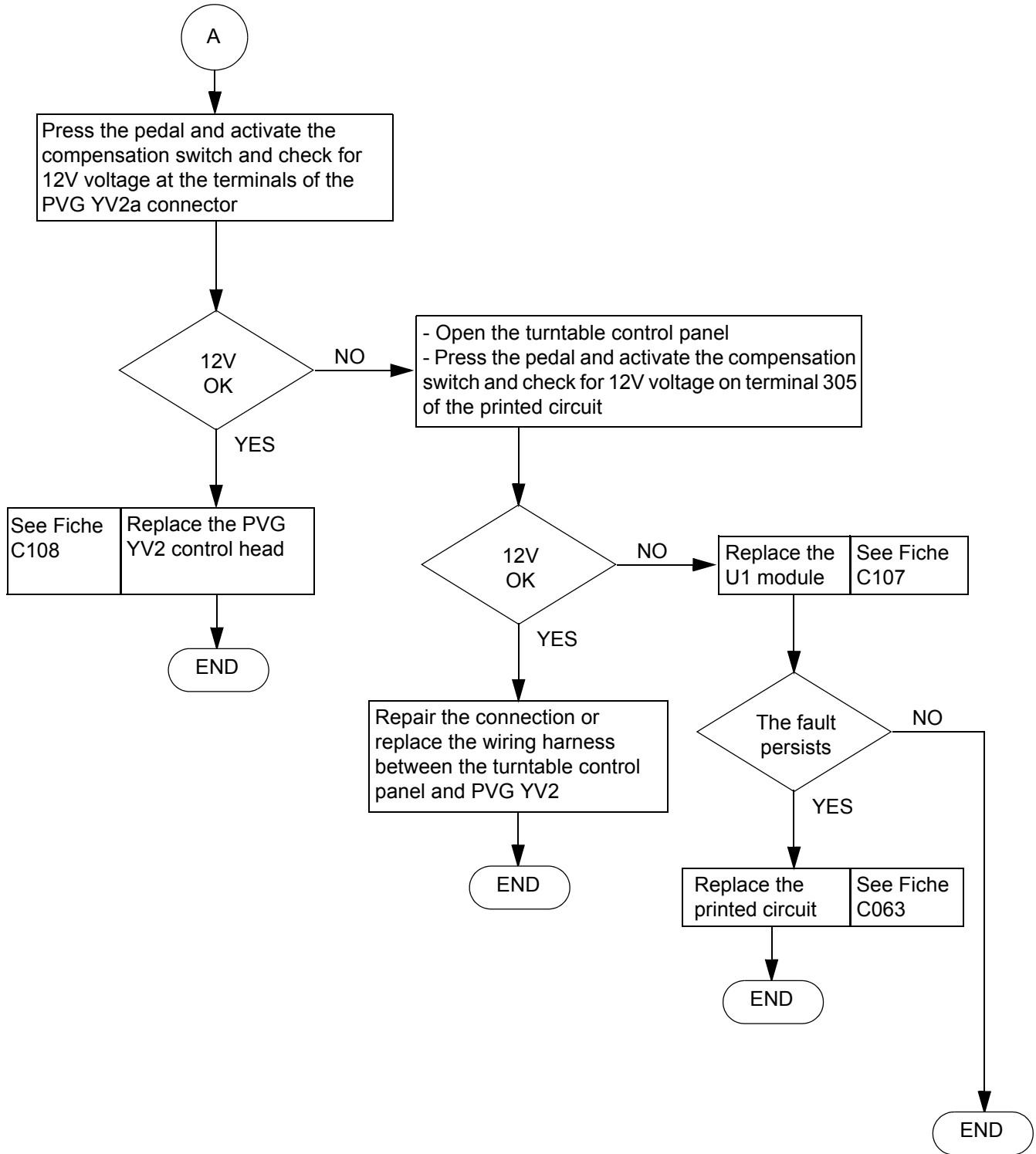

Sheet DP050	BREAKDOWN DETECTION FLOW CHART	Folio 3/5
	NO COMPENSATION MOVEMENT (UP AND/OR DOWN)	

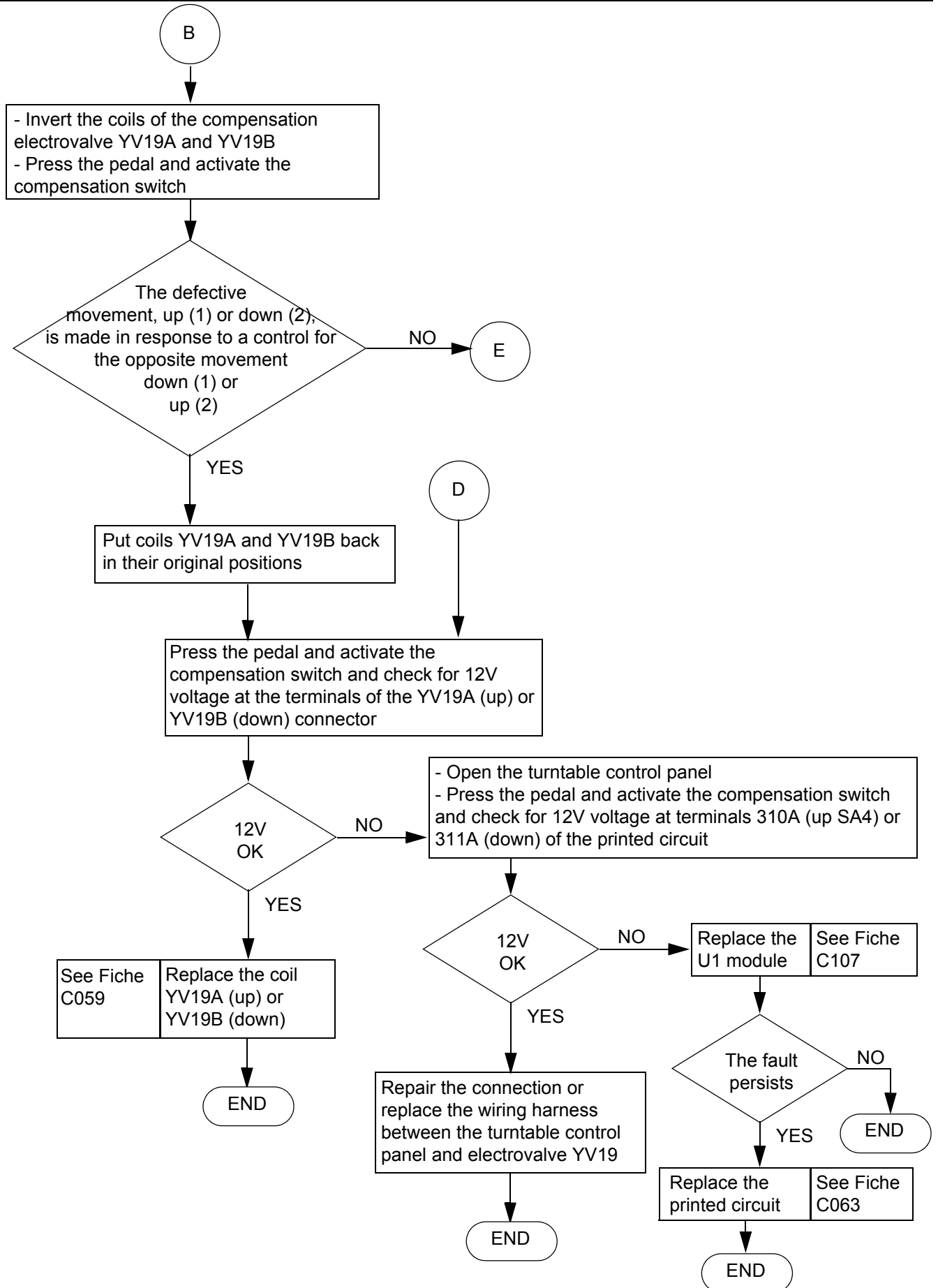

Sheet DP050	BREAKDOWN DETECTION FLOW CHART	Folio 4/5
	NO COMPENSATION MOVEMENT (UP AND/OR DOWN)	

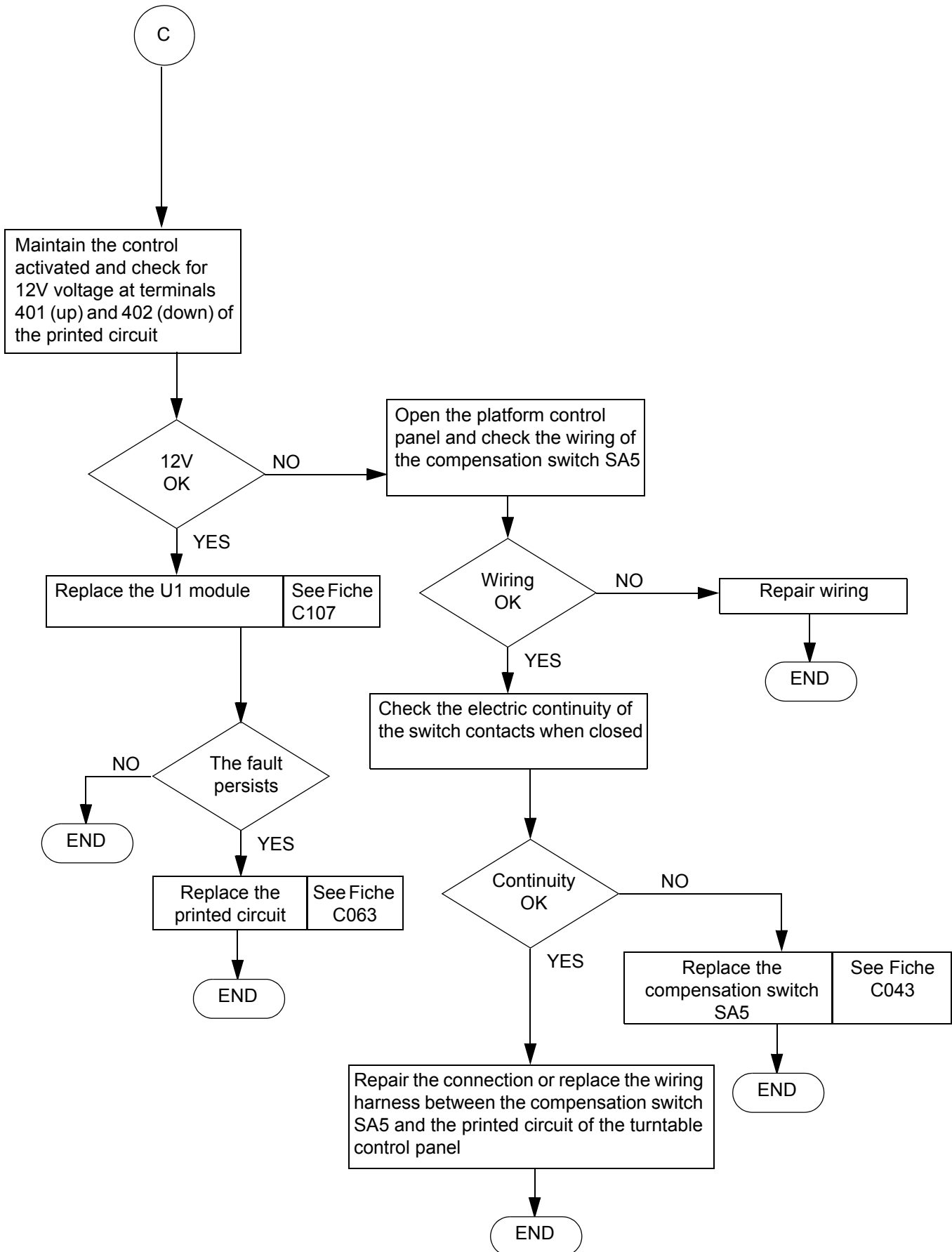

Sheet DP050	BREAKDOWN DETECTION FLOW CHART	Folio 5/5
	NO COMPENSATION MOVEMENT (UP AND/OR DOWN)	

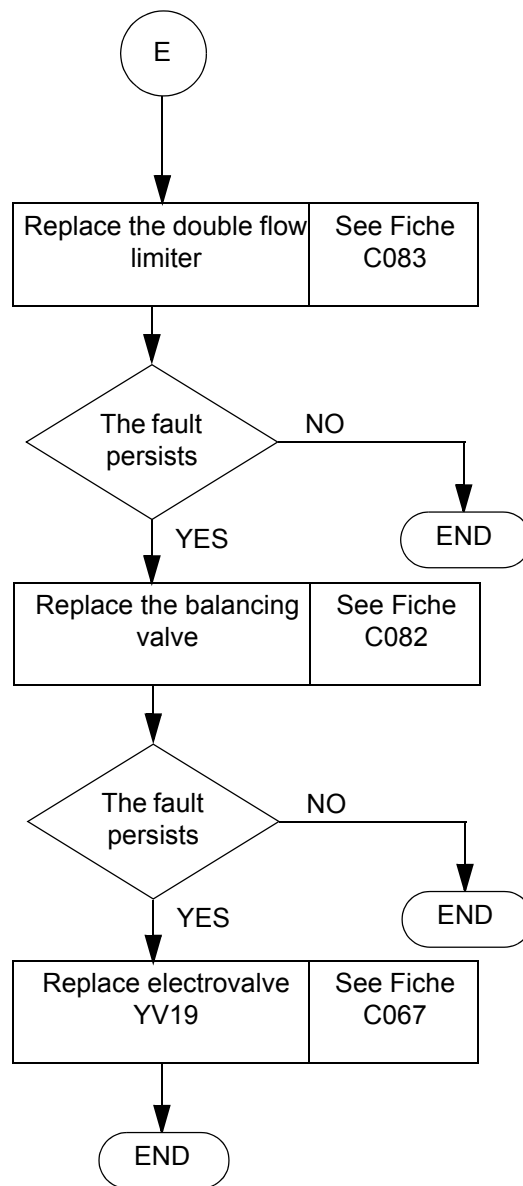

Sheet DP051	BREAKDOWN DETECTION FLOW CHART	Folio 1/2
	THE COMPENSATION MOVEMENT IS MADE WHEN PLATFORM ROTATION IS ACTIVATED	

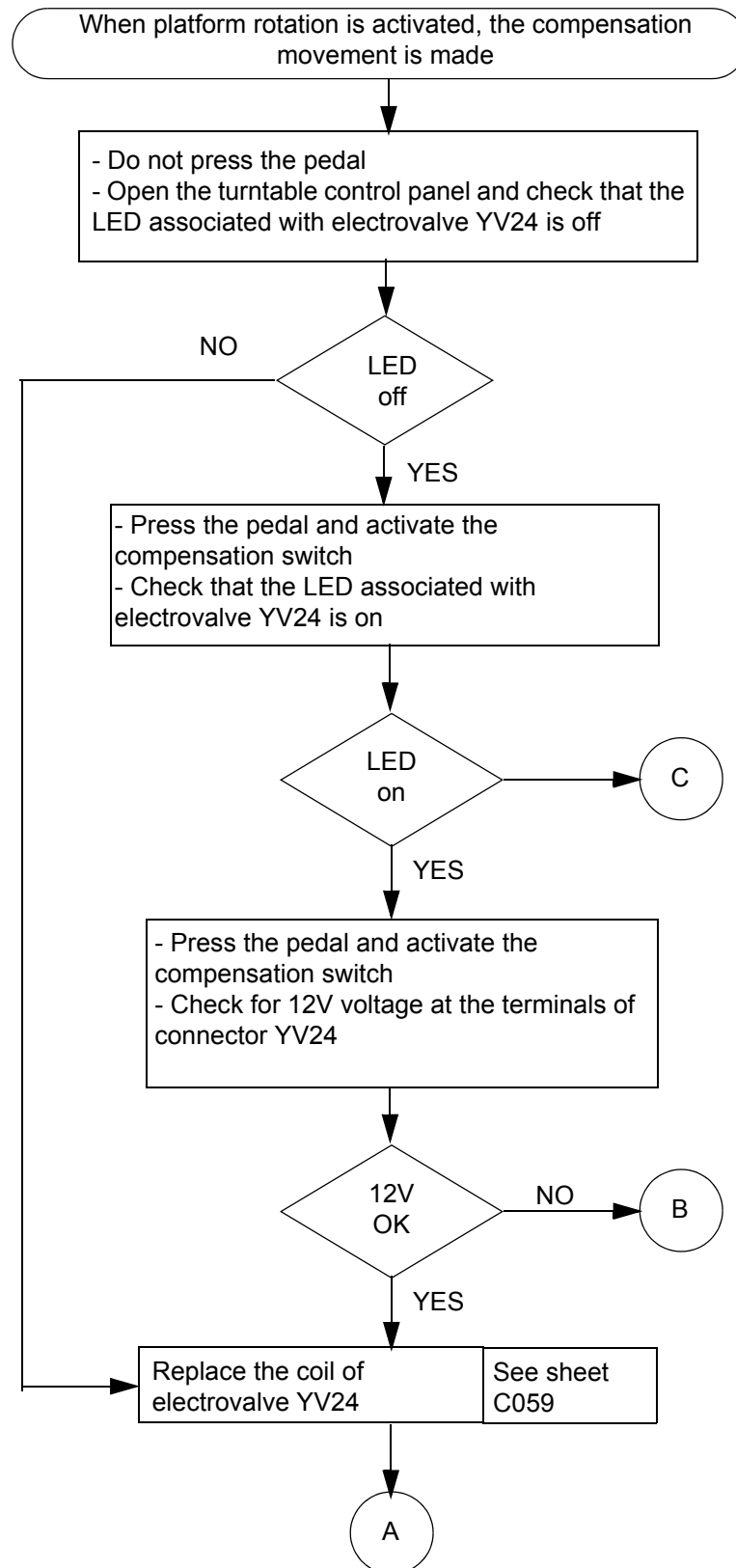

Sheet DP051	BREAKDOWN DETECTION FLOW CHART	Folio 2/2
	THE COMPENSATION MOVEMENT IS MADE WHEN PLATFORM ROTATION IS ACTIVATED	

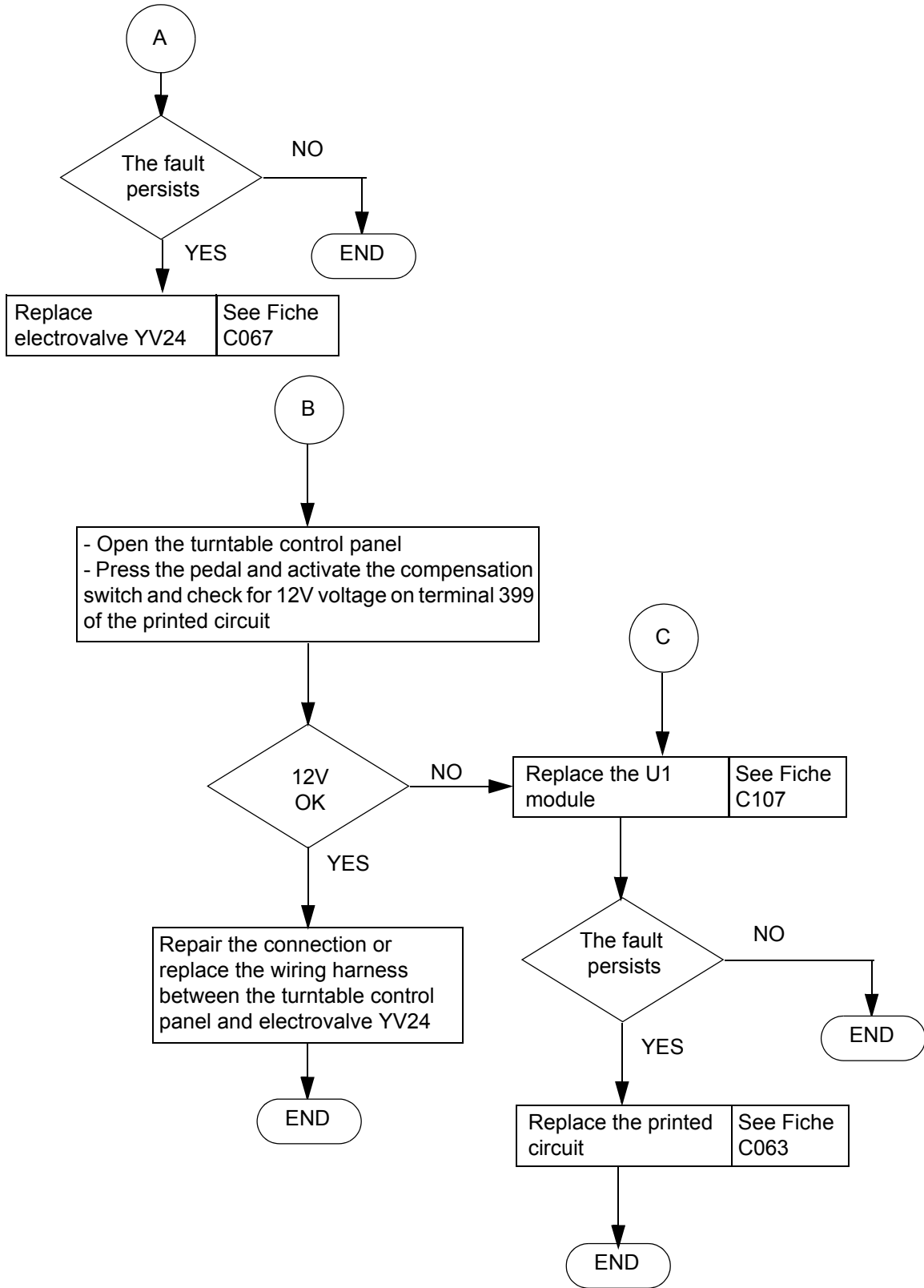

Sheet DP053	BREAKDOWN DETECTION FLOW CHART	Folio 1/5
	NO TELESCOPING MOVEMENT (IN AND/OR OUT) FROM THE PLATFORM (OR TURNTABLE) CONTROL PANEL	

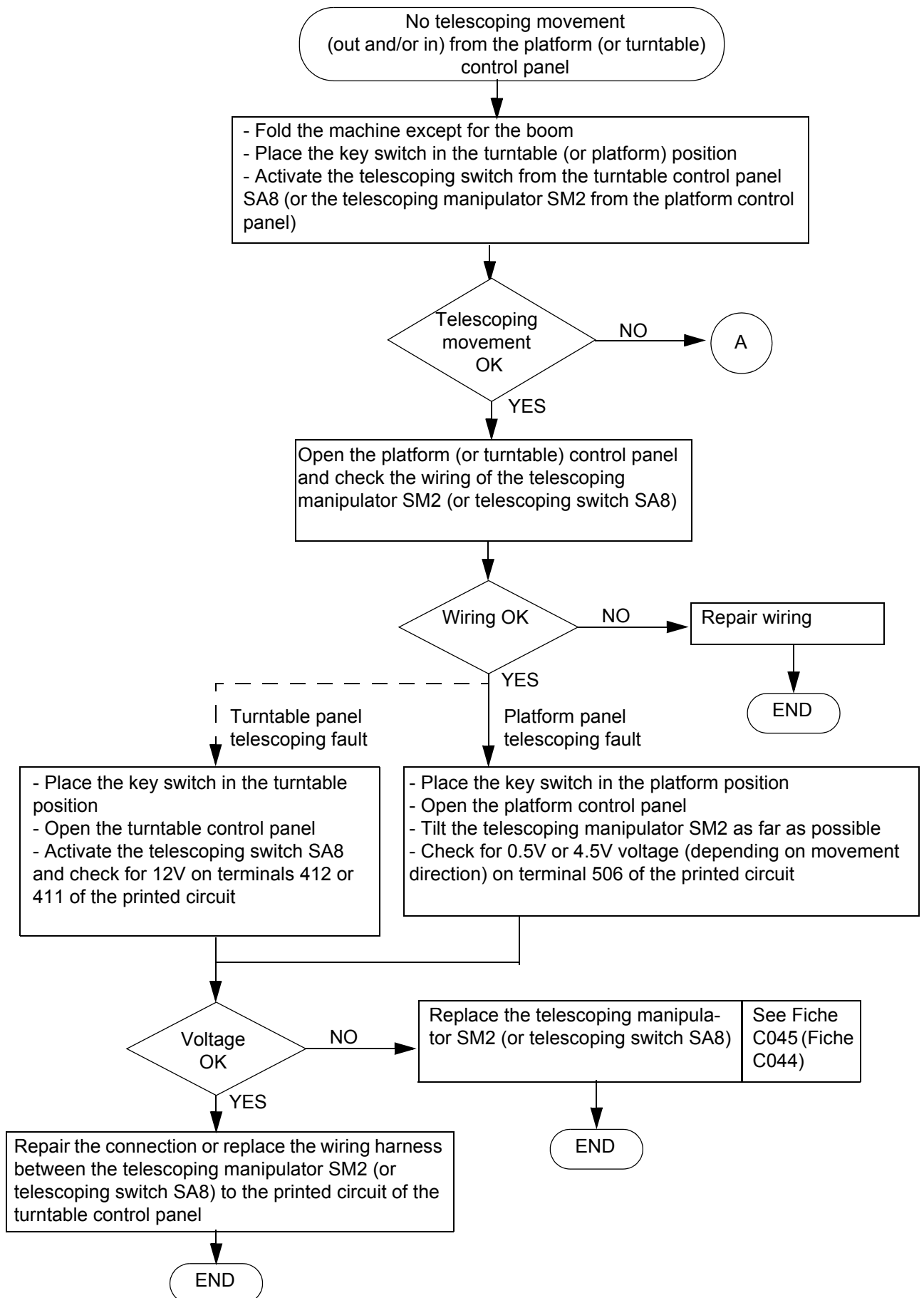

Sheet DP053	BREAKDOWN DETECTION FLOW CHART	Folio 2/5
	NO TELESCOPING MOVEMENT (IN AND/OR OUT) FROM THE PLATFORM (OR TURNABLE) CONTROL PANEL	

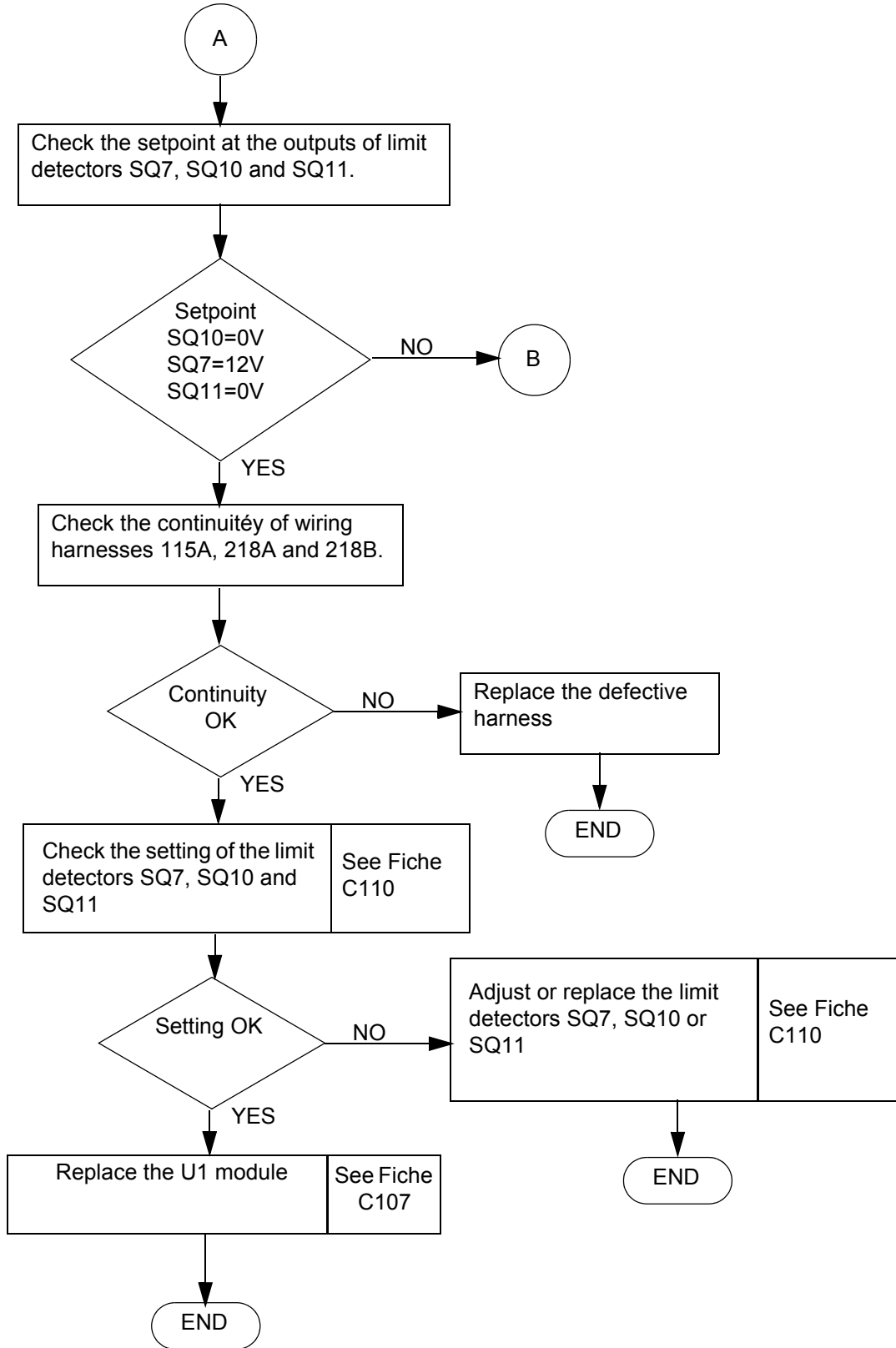

Sheet DP053	BREAKDOWN DETECTION FLOW CHART	Folio 3/5
	NO TELESCOPING MOVEMENT (IN AND/OR OUT) FROM THE PLATFORM (OR TURNTABLE) CONTROL PANEL	

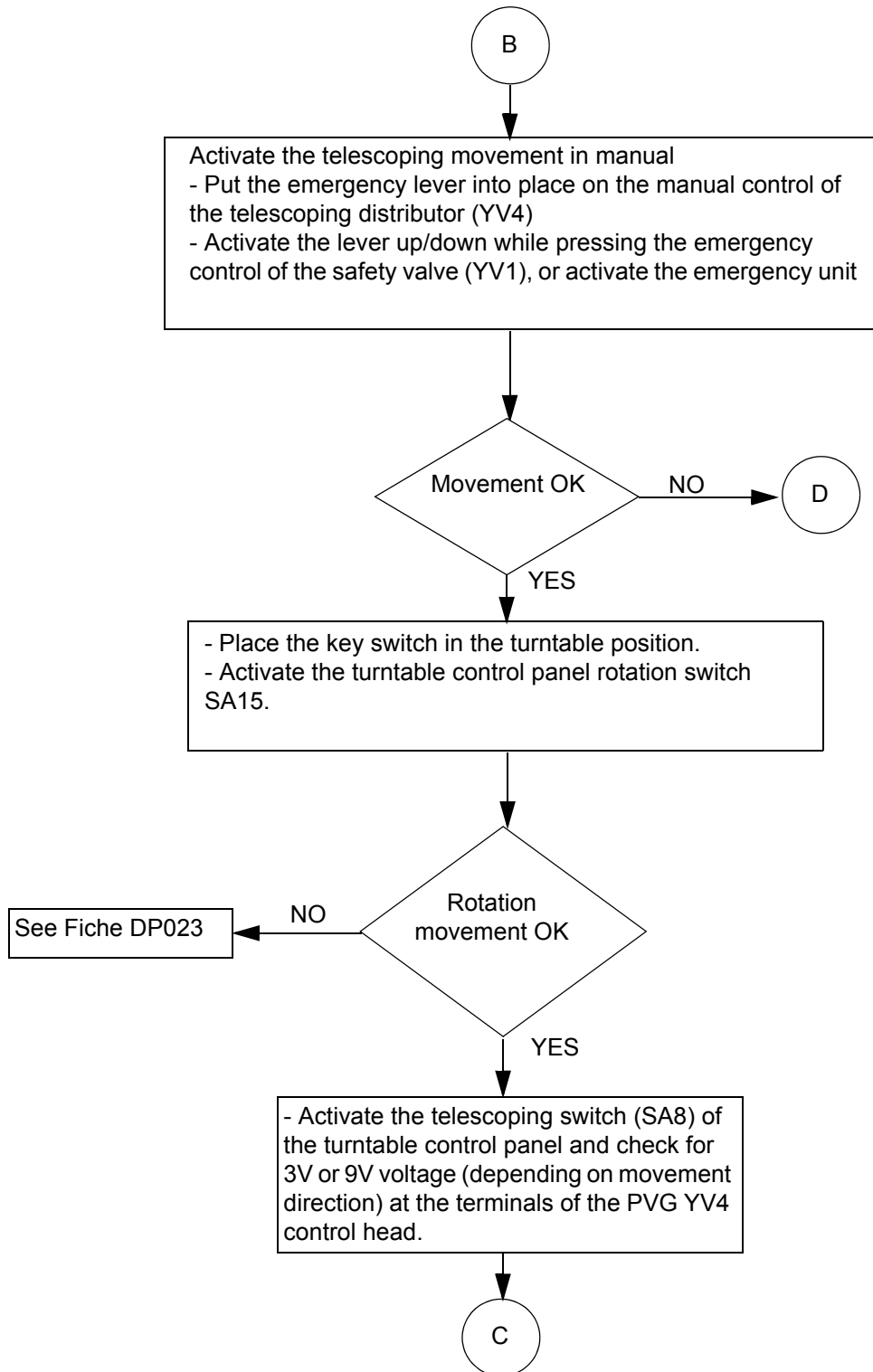

Sheet DP053	BREAKDOWN DETECTION FLOW CHART	Folio 4/5
	NO TELESCOPING MOVEMENT (IN AND/OR OUT) FROM THE PLATFORM (OR TURNTABLE) CONTROL PANEL	

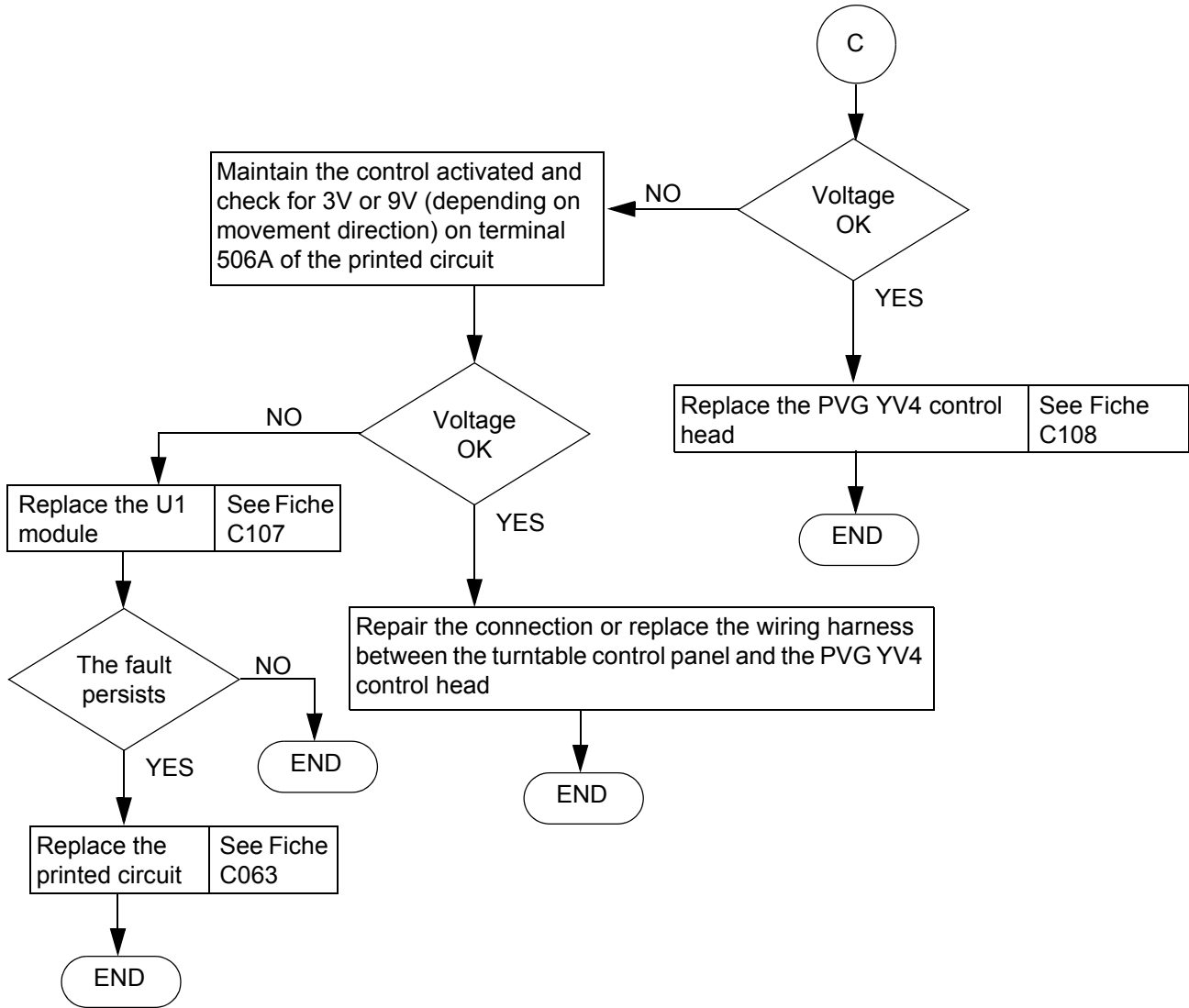

Sheet DP053	BREAKDOWN DETECTION FLOW CHART	Folio 5/5
	NO TELESCOPING MOVEMENT (IN AND/OR OUT) FROM THE PLATFORM (OR TURNTABLE) CONTROL PANEL	

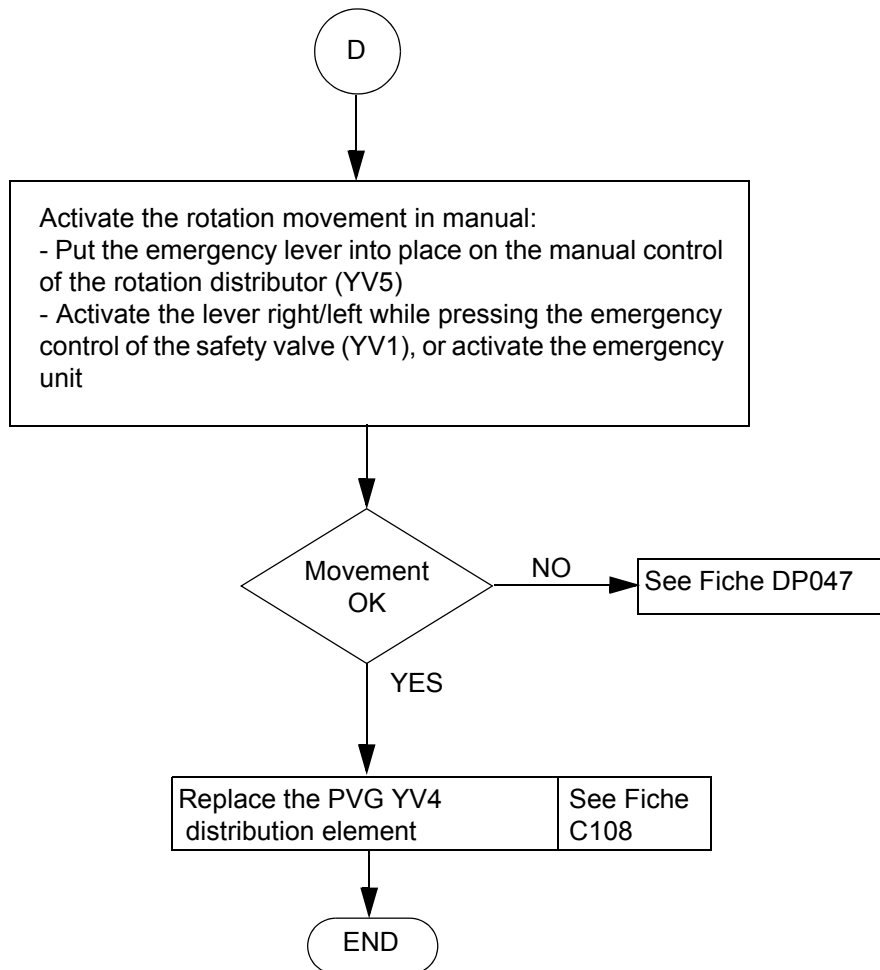

Sheet DP054	BREAKDOWN DETECTION FLOW CHART	Folio 1/5
	NO BOOM LIFTING MOVEMENT (UP AND/OR DOWN) FROM THE PLATFORM (OR TURNTABLE) CONTROL PANEL	

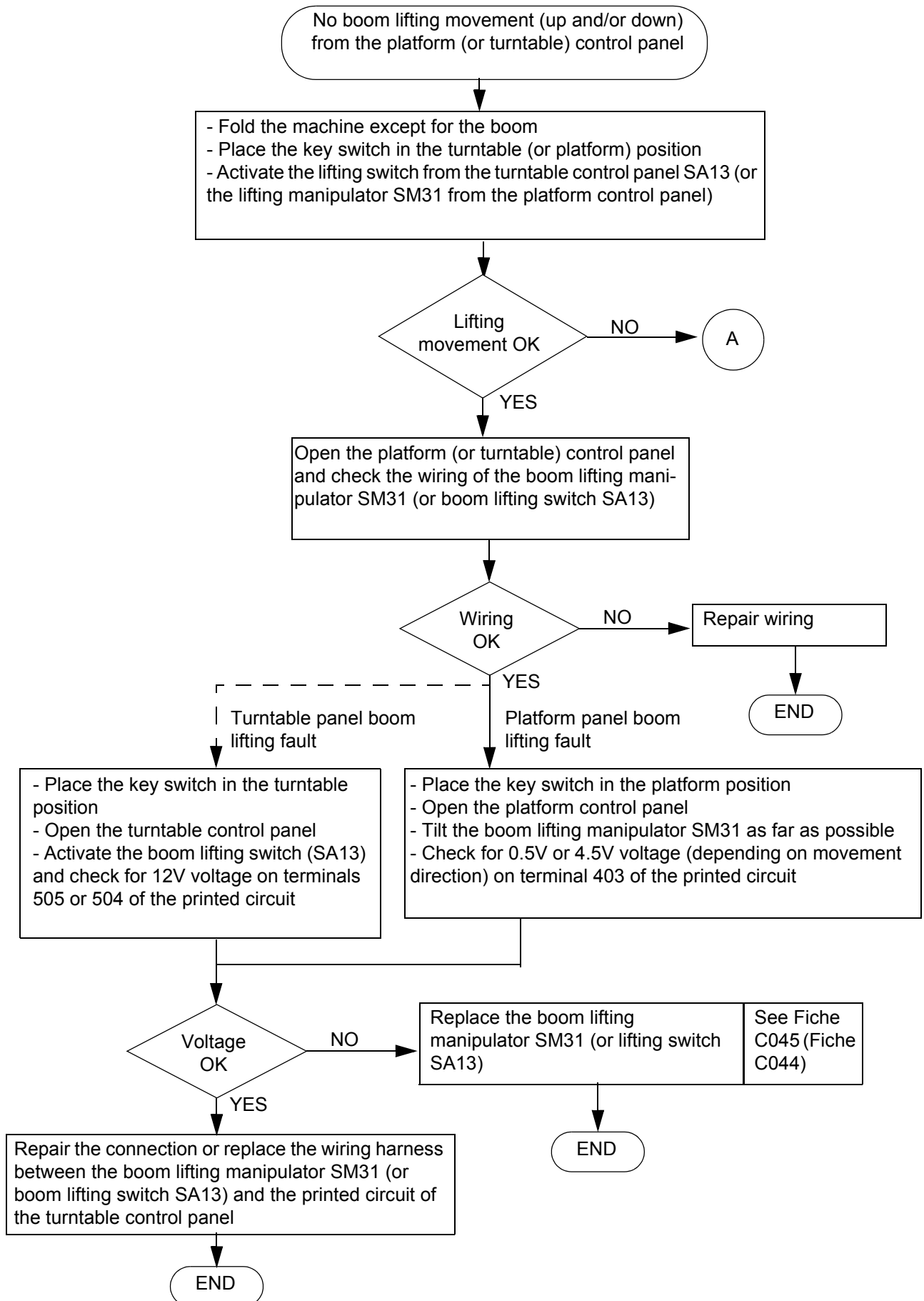

Sheet DP054	BREAKDOWN DETECTION FLOW CHART	Folio 2/5
	NO BOOM LIFTING MOVEMENT (UP AND/OR DOWN) FROM THE PLATFORM (OR TURNTABLE) CONTROL PANEL	

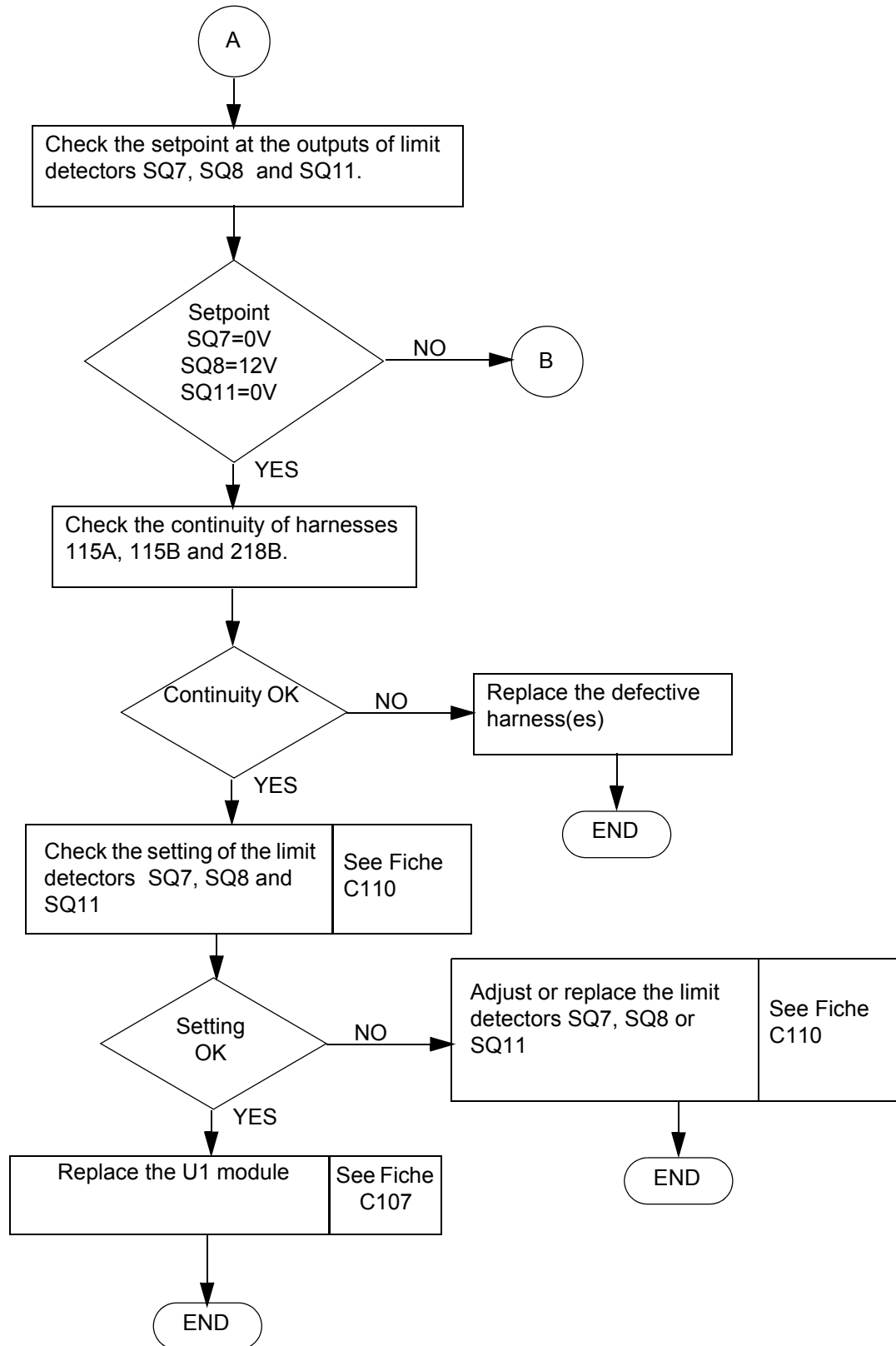

Sheet DP054	BREAKDOWN DETECTION FLOW CHART	Folio 3/5
	NO BOOM LIFTING MOVEMENT (UP AND/OR DOWN) FROM THE PLATFORM (OR TURNTABLE) CONTROL PANEL	

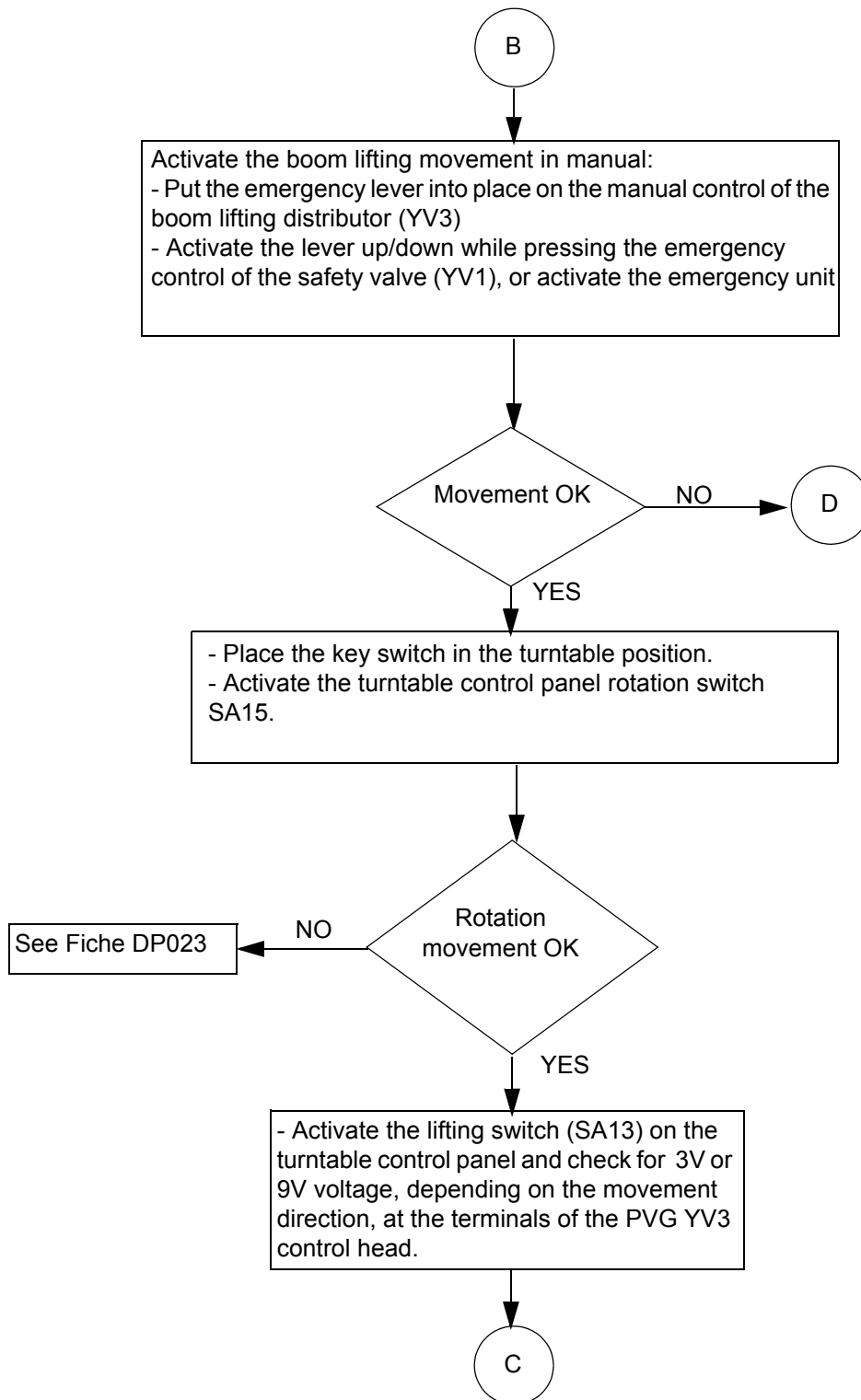

Sheet DP054	BREAKDOWN DETECTION FLOW CHART	Folio 4/5
	NO BOOM LIFTING MOVEMENT (UP AND/OR DOWN) FROM THE PLATFORM (OR TURNTABLE) CONTROL PANEL	

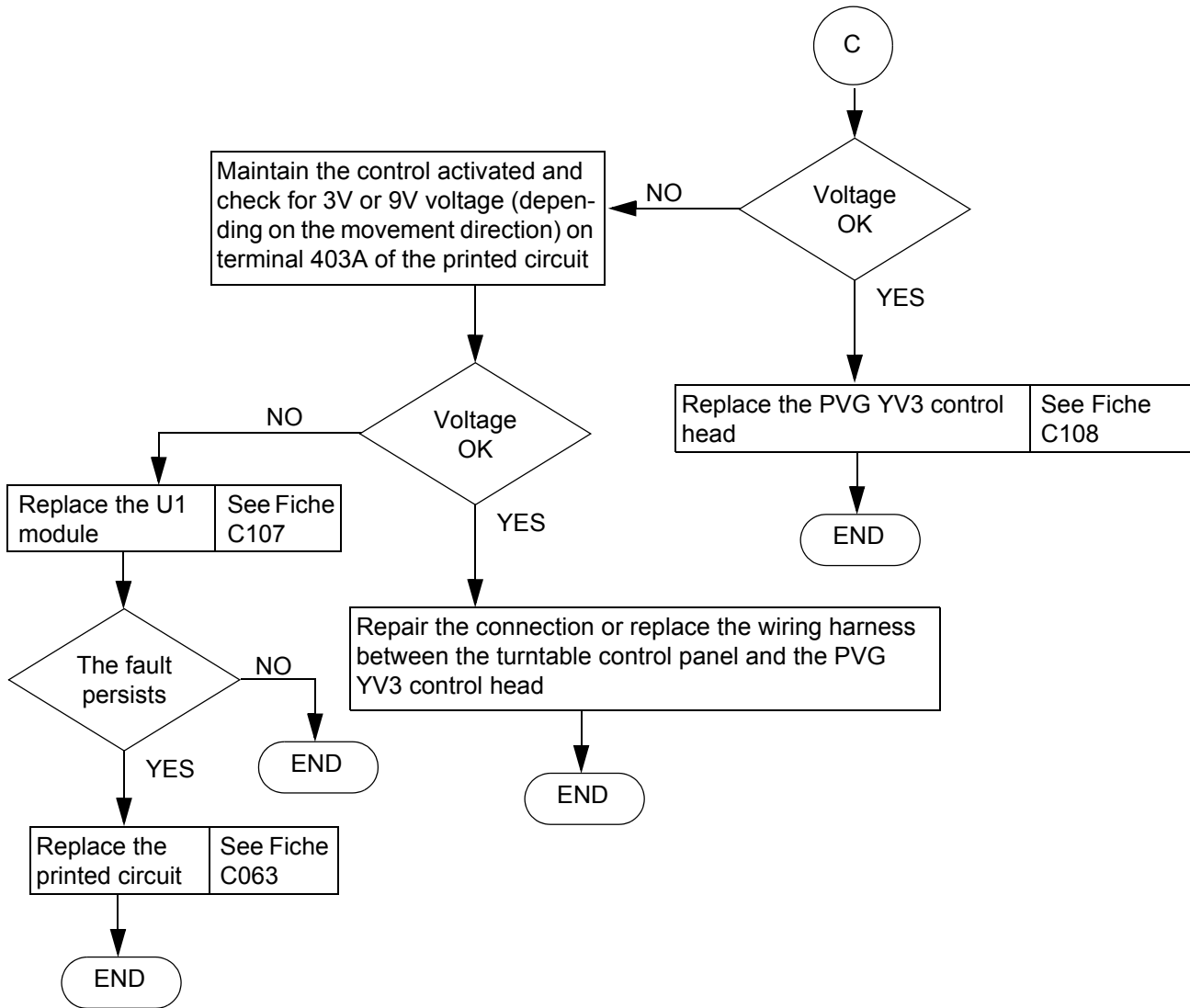

Sheet DP054	BREAKDOWN DETECTION FLOW CHART	Folio 5/5
	NO BOOM LIFTING MOVEMENT (UP AND/OR DOWN) FROM THE PLATFORM (OR TURNTABLE) CONTROL PANEL	

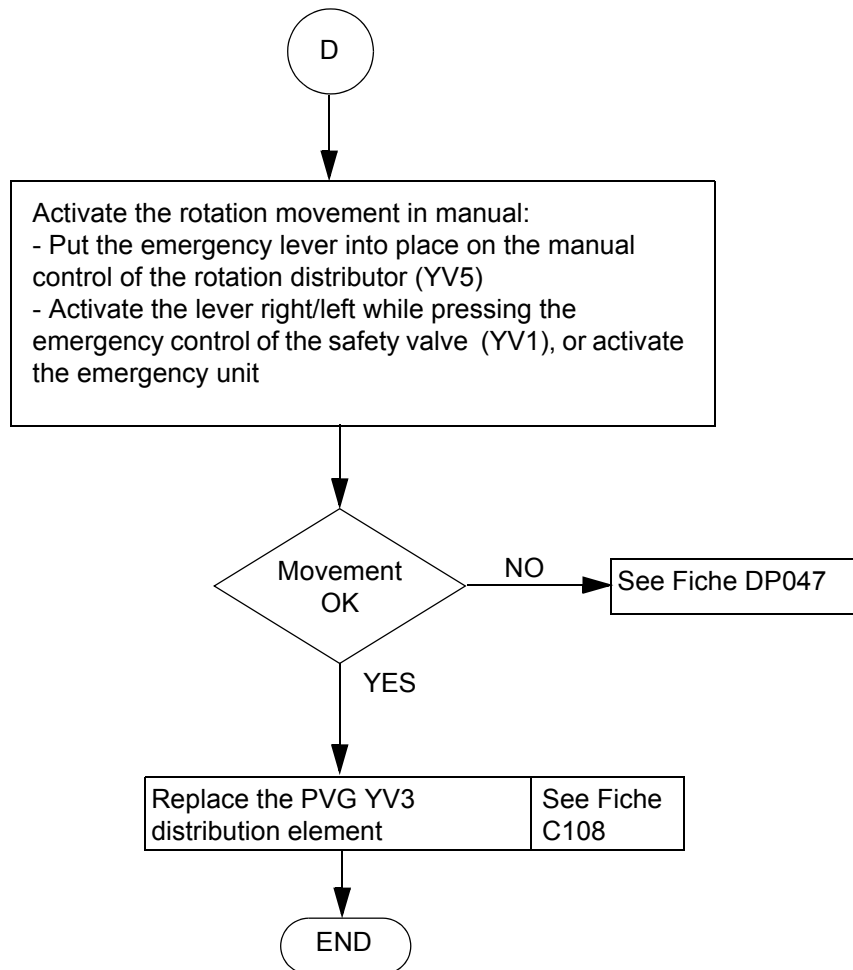

Sheet DP056	BREAKDOWN DETECTION FLOW CHART	Folio 1/2
	ONLY TRAVEL MICRO-SPEED IS AVAILABLE ON THE MACHINE REGARDLESS OF THE SPEED SELECTED	

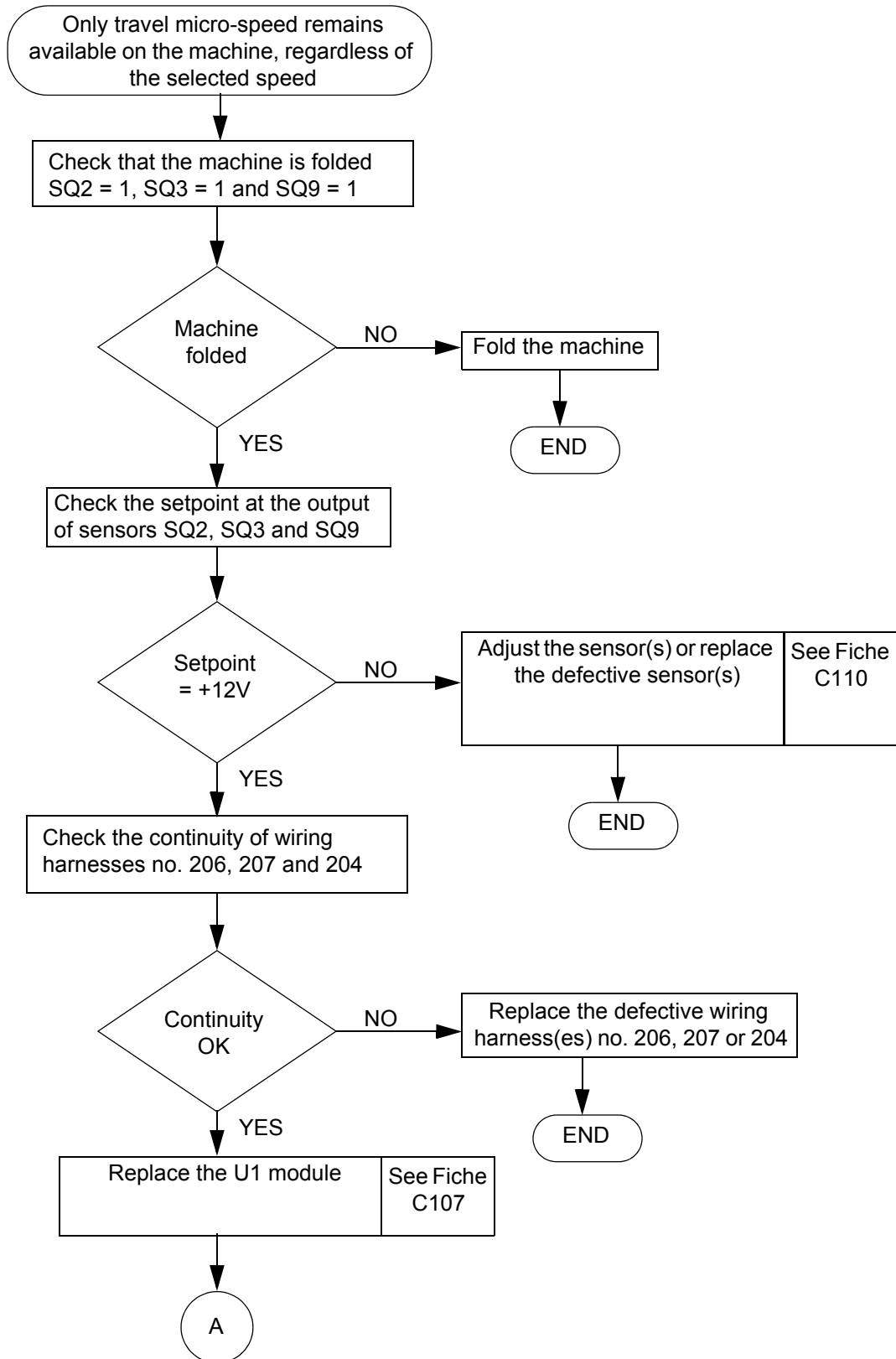

Sheet DP056	BREAKDOWN DETECTION FLOW CHART	Folio 2/2
	ONLY TRAVEL MICRO-SPEED IS AVAILABLE ON THE MACHINE REGARDLESS OF THE SPEED SELECTED	

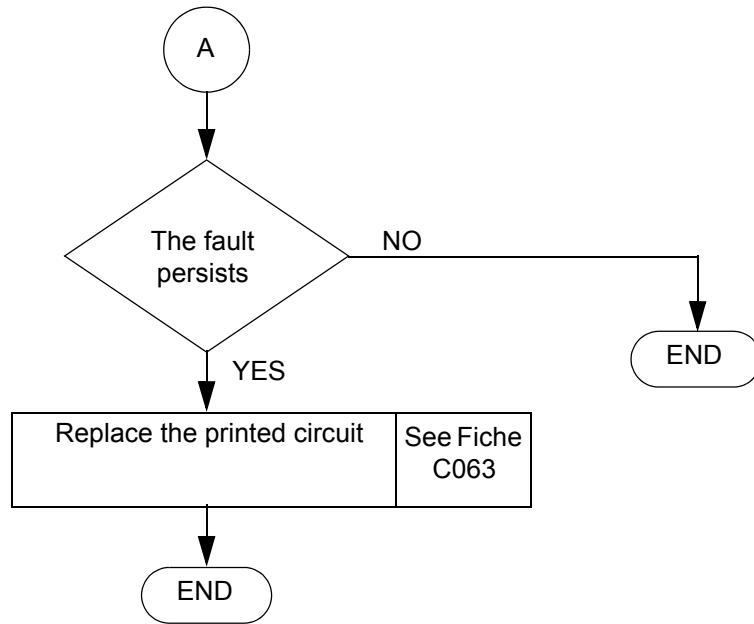

Sheet DP058	BREAKDOWN DETECTION FLOW CHART	Folio 1/1
	SUDDEN STOP OF TRAVEL MOVEMENT DURING A PLATFORM LIFTING OPERATION	

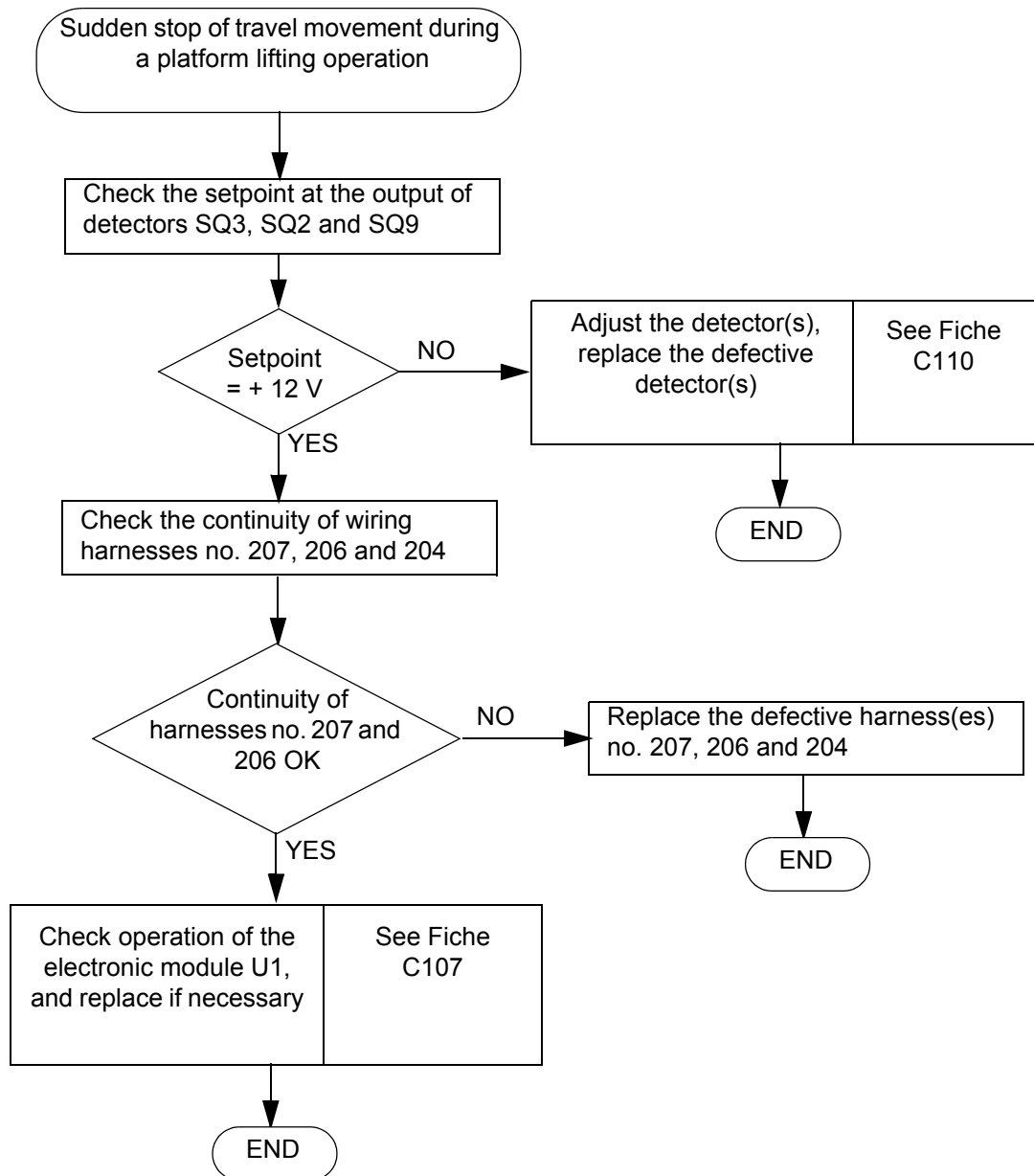

Sheet DP060	BREAKDOWN DETECTION FLOW CHART	Folio 1/4
	NO STEERING MOVEMENT (RIGHT OR LEFT)	

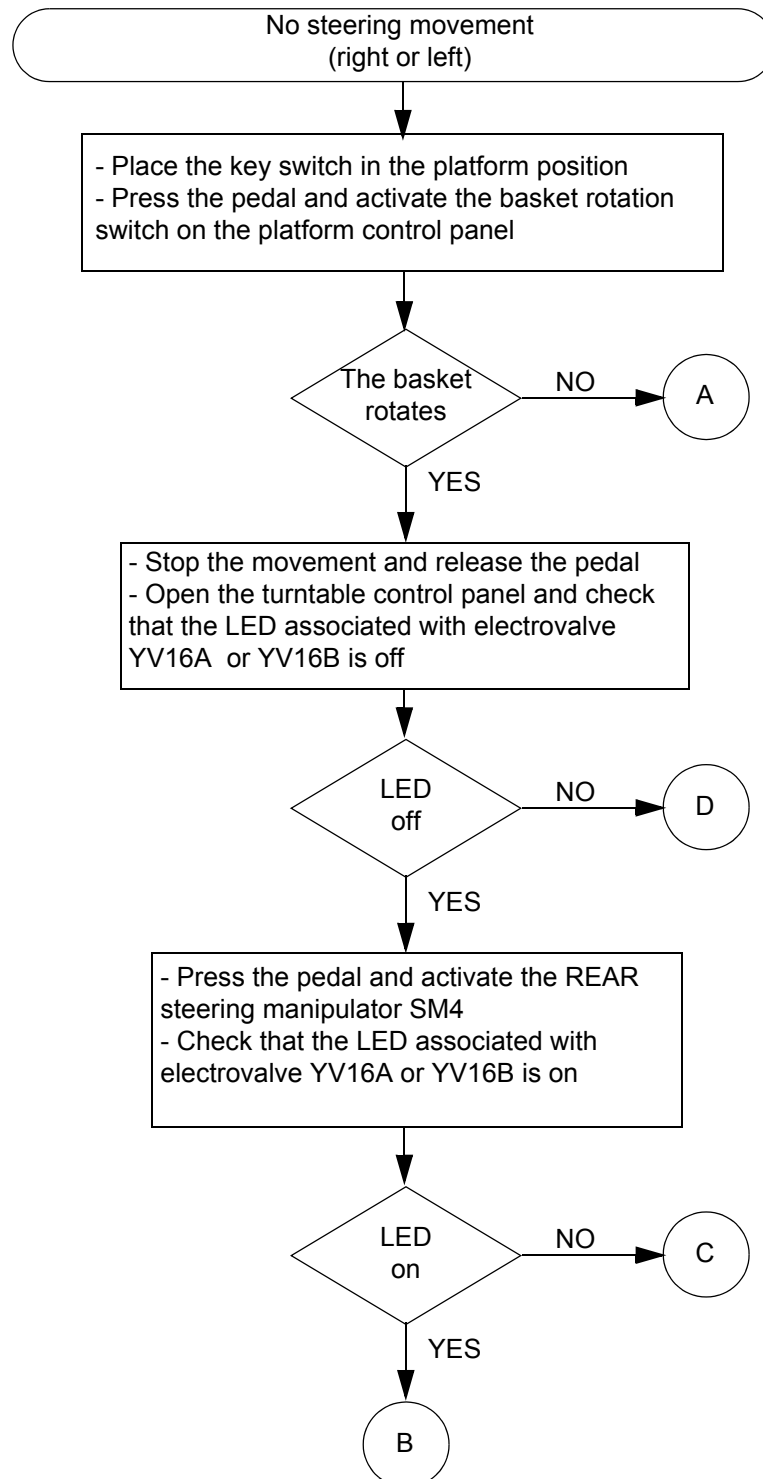

Sheet DP060	BREAKDOWN DETECTION FLOW CHART	Folio 2/4
	NO STEERING MOVEMENT (RIGHT OR LEFT)	

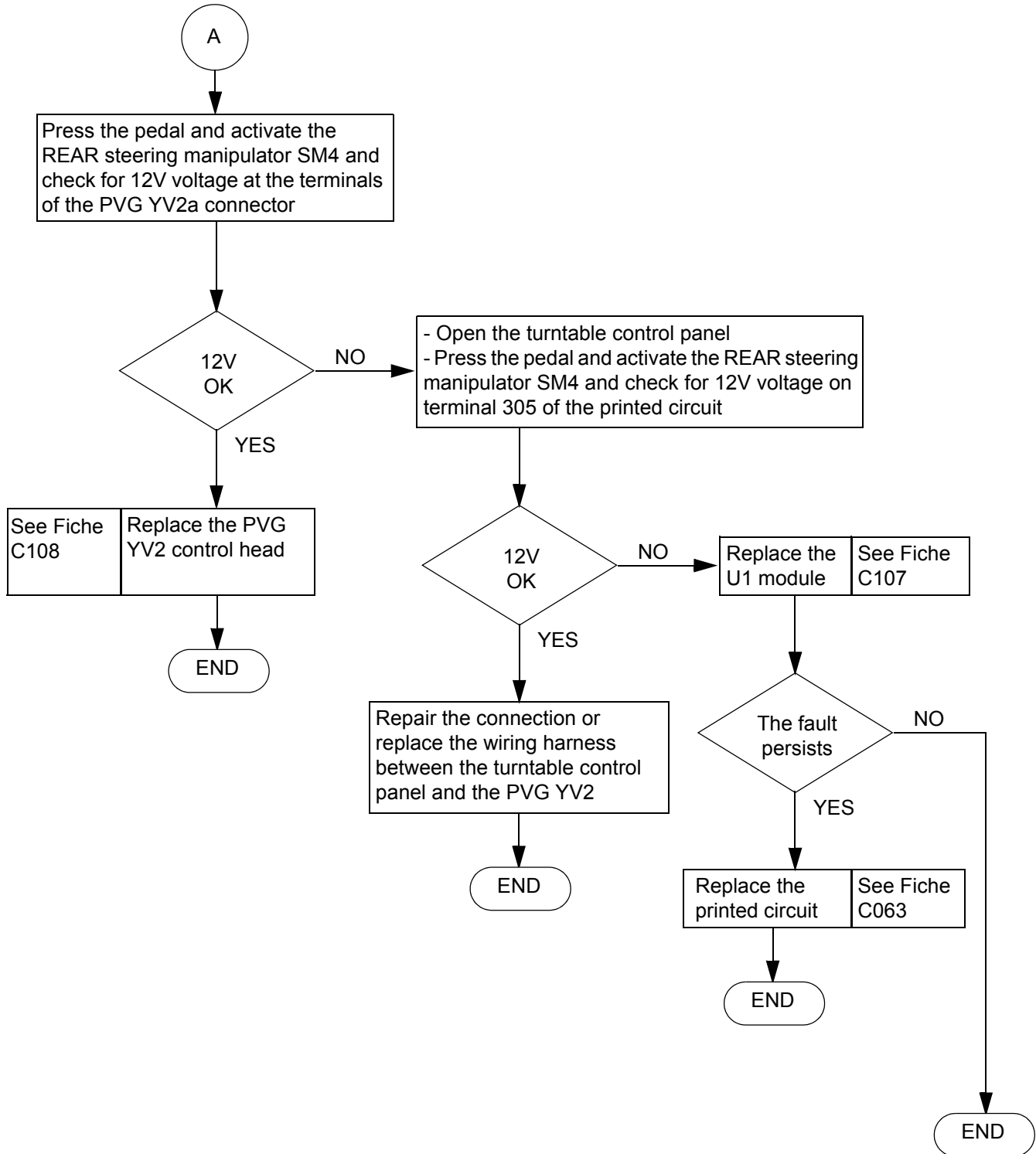

Sheet DP060	BREAKDOWN DETECTION FLOW CHART	Folio 3/4
	NO STEERING MOVEMENT (RIGHT OR LEFT)	

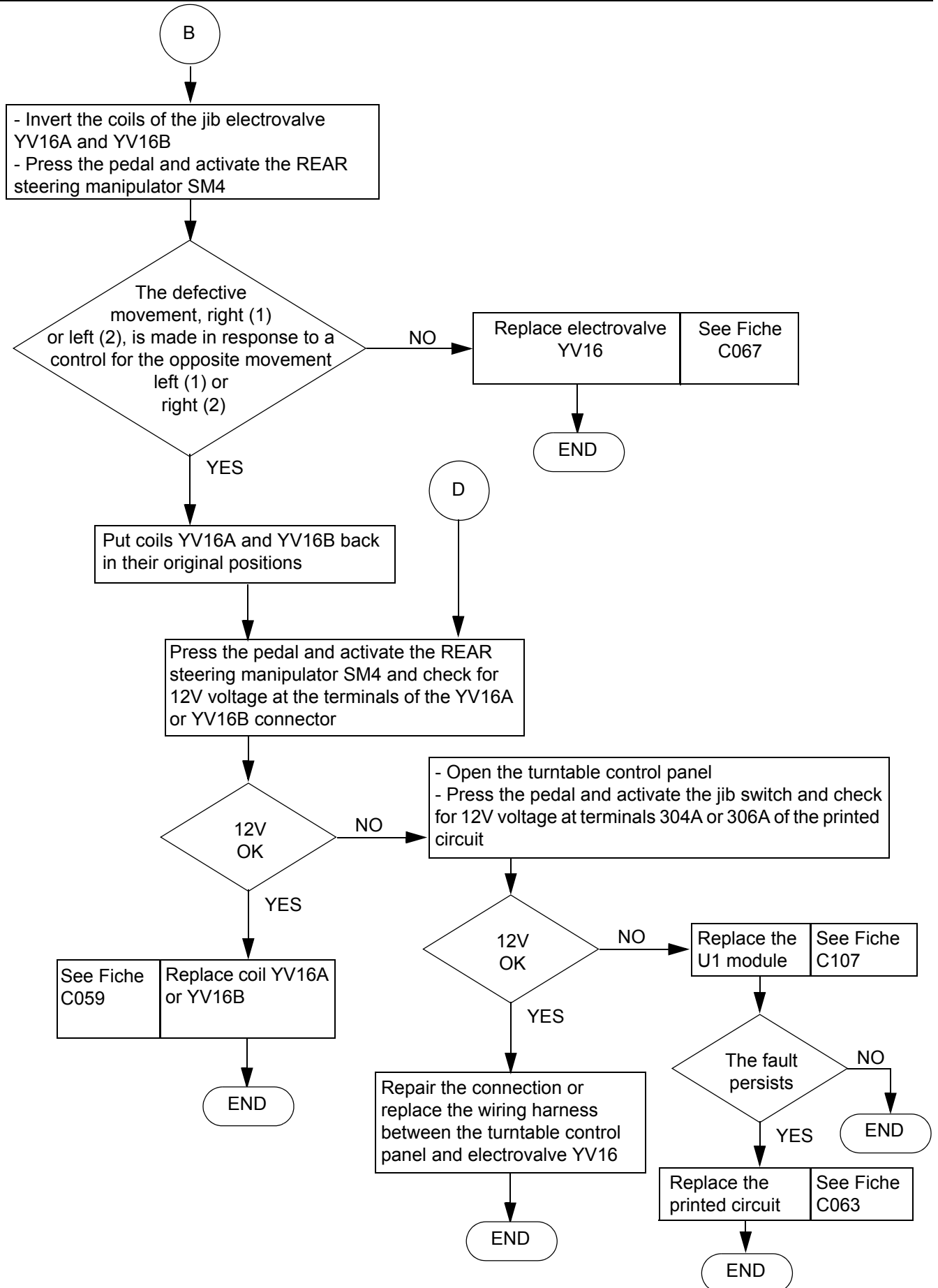

Sheet DP060	BREAKDOWN DETECTION FLOW CHART	Folio 4/4
	NO STEERING MOVEMENT (RIGHT OR LEFT)	

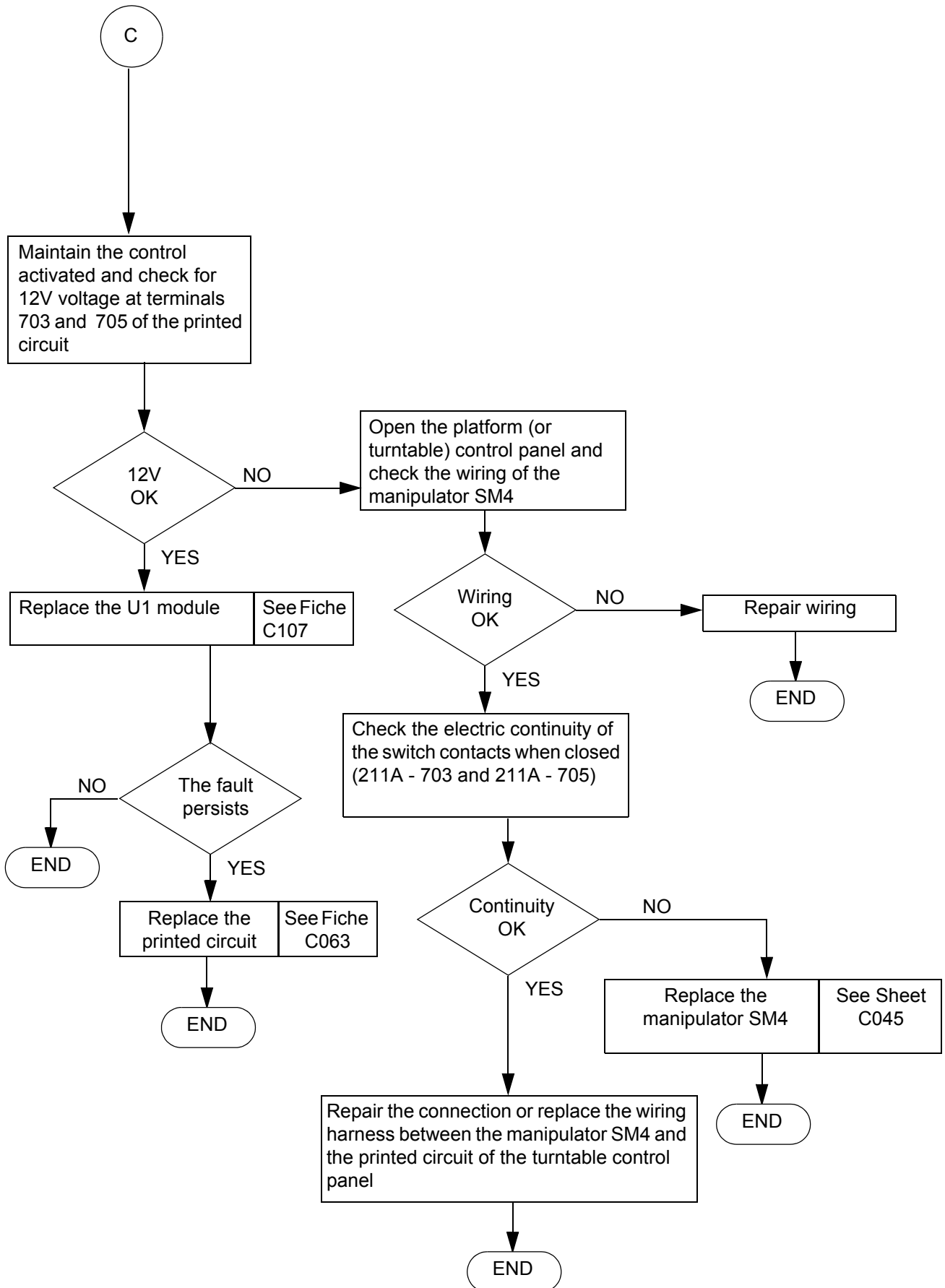

9 - CORRECTIVE MAINTENANCE PROCEDURE

List of corrective maintenance sheets:

<i>Sheet no.</i>	<i>Description</i>
FICHE C010	Changing a hose
FICHE C034	Changing a wheel
FICHE C035	Changing a wheel reducing gear or a hydraulic travel motor
FICHE C036	Changing a steering pivot
FICHE C039	Changing the tilt sensor
FICHE C040	Changing the horn
FICHE C041	Changing the tilt buzzer
FICHE C043	Changing an electric component on the top control panel
FICHE C044	Changing an electric component on the bottom control panel
FICHE C045	Changing a manipulator
FICHE C046	Changing the starter battery
FICHE C047	Changing a cover gas spring
FICHE C052	Changing the basket rotation hydraulic motor
FICHE C054	Changing the weighing rolling bearing
FICHE C056	Changing the hydraulic filter
FICHE C059	Changing a coil
FICHE C062	Changing a relay
FICHE C063	Changing the printed circuit
FICHE C064	Changing the fail-safe pedal
FICHE C067	Changing an electrovalve
FICHE C079	Changing a flow separator
FICHE C082	Changing a balancing valve - compensation function
FICHE C083	Changing a double flow limiter - compensation function
FICHE C085	Changing a steering pivot
FICHE C086	Dismantling and re-assembling the steering system
FICHE C087	Changing the steering cylinder
FICHE C091	Changing the hydraulic pump
FICHE C092	Changing the on/off travel hydraulic block
FICHE C093	Changing the distribution hydraulic block
FICHE C094	Dismantling / re-assembling the distribution hydraulic block
FICHE C097	Changing a cover
FICHE C098	Changing the thermal motor

<i>Sheet no.</i>	<i>Description</i>
FICHE C099	Changing the turntable rotation hydraulic motor
FICHE C100	Changing the swing joint
FICHE C101	Changing a counterweight
FICHE C103	Dismantling / re-assembling the jib
FICHE C104	Changing the basket rotation gearing
FICHE C106	Changing the turntable slew ring
FICHE C107	Changing the U1 electronic module
FICHE C108	Changing a control unit of the distribution block
FICHE C109	Changing the emergency electropump unit
FICHE C110	Changing a limit contact
FICHE C111	Adjusting a pressure limiter
FICHE C112	Changing a balancing block
FICHE C114	Changing the pressure limiter on the emergency hydraulic circuit
FICHE C115	Changing the jib cylinder
FICHE C116	Changing the boom lifting cylinder
FICHE C117	Changing the turntable rotation reducing gear
FICHE C118	Changing a circuit selector - travel hydraulic block
FICHE C119	Dismantling / re-assembling the boom

Sheet C010	CORRECTIVE MAINTENANCE SHEET	Folio 1/1
	CHANGING A HOSE	



Caution!

Ensure that the oil is not too hot.



Caution!

Use a container to collect oil to prevent pollution of the environment.

1 - Preliminary operations

- Put the machine in the maintenance configuration (see § 6.3, page 32).
- Switch off electric power (see § 6.4, page 32).
- Close the shut-off valve, if any; if not, empty the hydraulic tank.

2 - Removing a hose

- Disconnect the hose from the equipment to which it is connected.

NB: *Unscrew the hose slowly to release residual hydraulic pressure.*

- Protect the holes of the equipment using caps.

3 - Installing a hose

- Reconnect a new hydraulic hose.
- Put the machine back into the operational configuration.
- Make several movements using the hose to purge the hydraulic circuit.
- Check the level in the hydraulic oil tank.

Sheet C034	CORRECTIVE MAINTENANCE SHEET	Folio 1/1
	CHANGING A WHEEL	

1 - Preliminary operations

- Put the machine in the maintenance configuration (see § 6.3, page 32).
- Switch off electric power (see § 6.4, page 32).

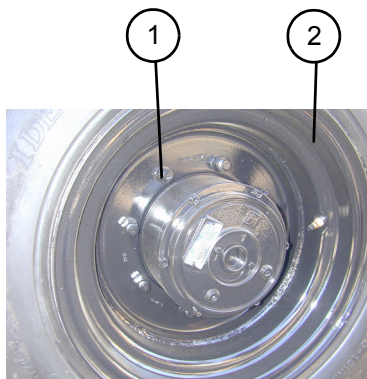

2 - Removing a wheel

- Unblock (without completely unscrewing) the fixing screws (1) of the wheel to be removed.
- Raise the machine using a jack or hoist.
- Remove the fixing screws (1) from the wheel and remove the wheel (2).

3 - Installing a wheel

- Put a new wheel into place and put back the fixing screws.
- Put the machine on the ground.
- Tighten the fixing screws to the recommended torque (see tightening torque value table).
- Put the machine back into the operational configuration.



Caution!

Use a container to collect oil to prevent pollution of the environment.



Caution!

It is essential to put the component in slings before dismantling/re-assembling it.

Sheet C035	CORRECTIVE MAINTENANCE SHEET	Folio 1/2
	CHANGING A WHEEL REDUCING GEAR OR A TRAVEL HYDRAULIC MOTOR	

 **Caution!**
Ensure that the oil is not too hot.

 **Caution!**
Use a container to collect oil to prevent pollution of the environment.

 **Caution!**
It is essential to put the component in slings before dismantling/re-assembling it.

1 - Preliminary operations

- Put the machine in the maintenance configuration (see § 6.3, page 32).
- Switch off electric power (see § 6.4, page 32).
- Remove the wheel corresponding to the element to be removed (see corresponding sheet).

2 - Removing a wheel reducing gear or a hydraulic motor

NB: *Figure 1: steering axle.
Figure 2: fixed axle.*

- If working on a steering axle, uncouple the steering connecting rod from the pivot.
- Mark and disconnect the hoses of the hydraulic motor (1) and reducing gear (2).

NB: *Unscrew the hose slowly to release residual hydraulic pressure.*

- Put caps on the hoses.
- Place a wedge under the wheel reducing gear.
- Remove the reducing gear / motor assembly by removing the fixing bolts (3).
- Unscrew the screws (4) fixing the hydraulic motor to the wheel reducing gear.
- Replace the defective hydraulic motor or reducing gear.

3 - Installing a wheel reducing gear or a hydraulic motor

- Assemble the hydraulic motor to the reducing gear using fixing screws equipped with new grower washers.
- Fix the hydraulic motor using the four fixing bolts, equipped with new elastic washers.
- Re-install the reducing gear / motor assembly and secure with fixing screws. Tighten to the torque recommended (see tightening torque value table).
- In the case of a steering axle, couple the steering connecting rod to the pivot.
- Reconnect the hydraulic hoses to the hydraulic motor and the reducing gear hose equipped with a new seal, according to the marks made when dismantling.

4 - Additional operations

- Check the level of oil in the wheel reducing gear (see corresponding sheet).
- Put the wheel back (see corresponding sheet).
- Put the machine back into the operational configuration.
- Make several travel movements to purge the hydraulic circuit.
- Check the level of the hydraulic oil tank.

Sheet C035	CORRECTIVE MAINTENANCE SHEET	Folio 2/2
	CHANGING A WHEEL REDUCING GEAR OR A TRAVEL HYDRAULIC MOTOR	

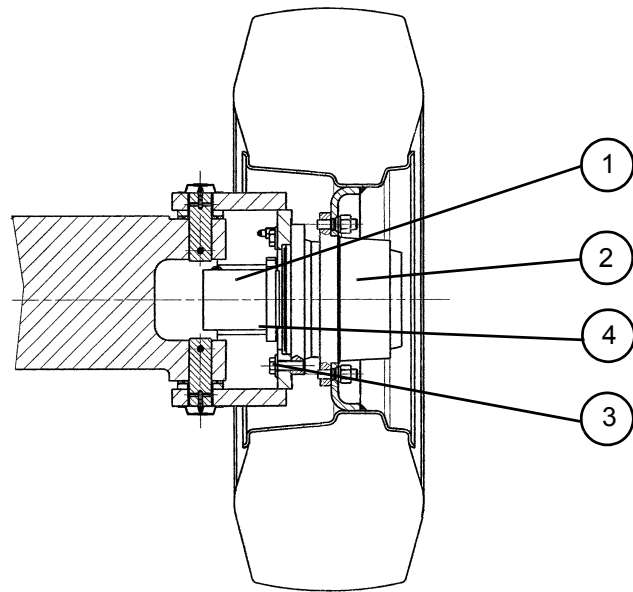

Figure 1

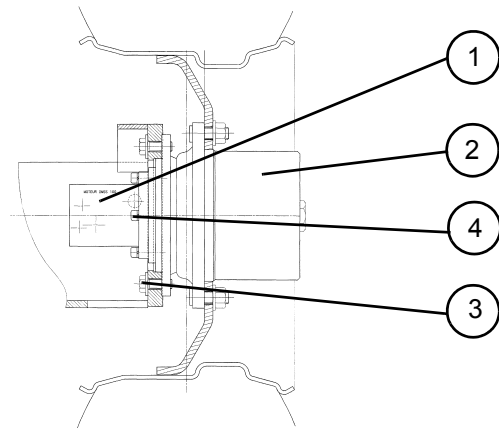

Figure 2

Sheet C036	CORRECTIVE MAINTENANCE SHEET	Folio 1/2
	CHANGING A STEERING PIVOT	



Caution!

Ensure that the oil is not too hot.



Caution!

Use a container to collect oil to prevent pollution of the environment.



Caution!

It is essential to put the component in slings before dismantling/re-assembling it.

1 - Preliminary operations

- Put the machine in the maintenance configuration (see § 6.3, page 32).
- Switch off electric power (see § 6.4, page 32).
- Remove the wheel corresponding to the element to be removed (see corresponding sheet).
- Remove the motor and reducing gear corresponding to the pivot to be removed (see corresponding sheet).

2 - Removing a pivot (see figure 1)

- Place a wedge under the steering pivot (1).
- Remove the fixing screw (2) from the steering clevis pin.
- Remove the steering clevis pin (3).
- Remove the two screws (4) from the caps on the pivot pin and remove the two caps (5).
- Take out the Mécanindus pin from each pivot pin (6), then remove the pivot pin and support washer (7).
- Remove the steering pivot (1).

3 - Installing a reducing gear or a motor

- Put the steering pivot into place.
- Replace the pins, lubricators and support washers if necessary.
- Put back the support washers and pivot pins, and block using new Mécanindus pins.
- Put back the pivot pin caps and fix using fixing screws and washers.
- Adjust the wheel alignment, if necessary:
 - slacken the counter-nut (8),
 - tighten or slacken the clevis (9) to adjust the length of the steering bar.
 - tighten the counter-nut (8).
- Put back the steering clevis pin and fix using the screw equipped with a new grower washer.

NB: *When installing pins, take measures necessary to avoid deteriorating the pins, rings and bores.*

4 - Additional operations

- Put back the motor and reducing gear (see corresponding sheet).
- Put back the wheel (see corresponding sheet).
- Put the machine back into the operational configuration.
- Make several travel movements to purge the hydraulic circuit
- Check the oil level of the wheel reducing gear (see corresponding sheet).
- Check the hydraulic oil tank level.
- Lubricate the pins with the lubricators.

Sheet C036	CORRECTIVE MAINTENANCE SHEET	Folio 2/2
	CHANGING A STEERING PIVOT	

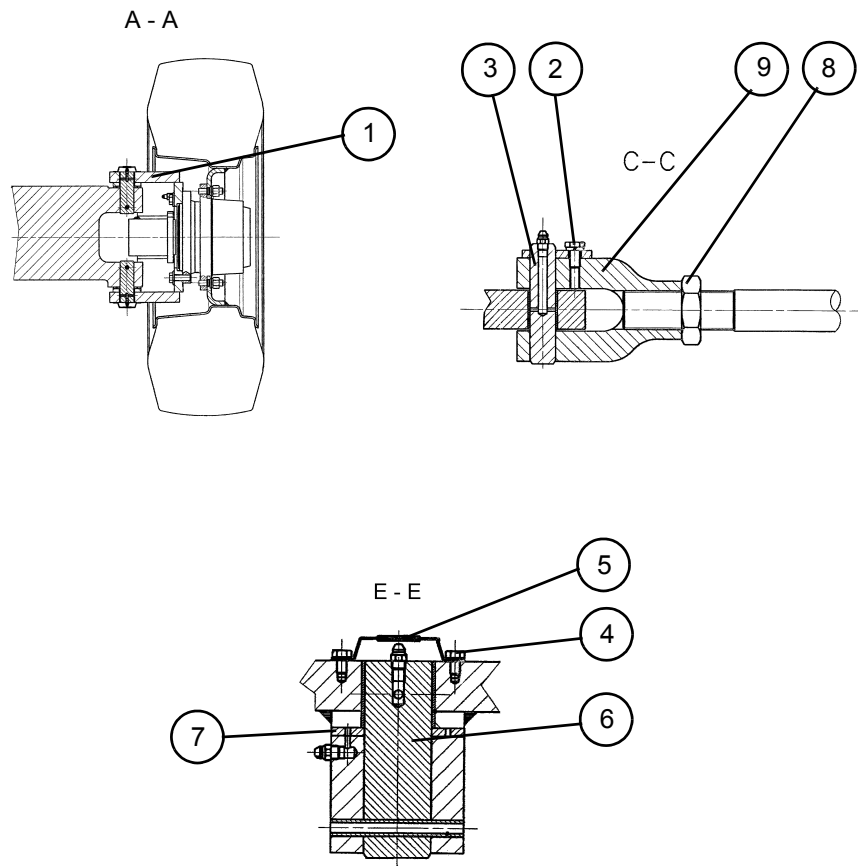

Figure 1

Sheet C039	CORRECTIVE MAINTENANCE SHEET	Folio 1/1
	CHANGING THE TILT SENSOR	

 **Caution!**
Do not use the machine during maintenance operations.

1 - Preliminary operations

- Put the machine on a flat surface with zero slope.
- Put the machine into the maintenance configuration (see § 6.3, page 32).
- Switch off electric power (see § 6.4, page 32).

2 - Removing the tilt sensor

- Mark and disconnect the electric connections of the tilt sensor.
- Remove the tilt sensor (2) by unscrewing the fixing bolts (1).

3 - Installing the tilt sensor

- Put a new tilt sensor into place and fix using the fixing bolts (1).
- Reconnect the electric connections according to the marks made during dismantling.
- Place a spirit level (3) on the top surface of the tilt sensor and set the adjustment screws (4) so that the tilt sensor is level.

NB: *The spirit level (3) is built into certain tilt sensors.*

- Put the machine back into the operational configuration.

4 - Tilt sensor operating test

- Extend the machine.
- Tilt the tilt sensor and check that the buzzer sounds.
- Check that after 1 or 2 seconds, extension or travel movements have been disabled.

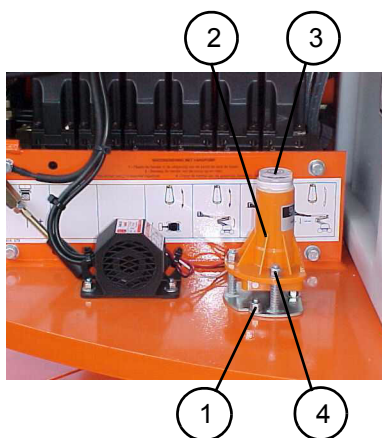

HA16/18PX - HA46/51 JRT

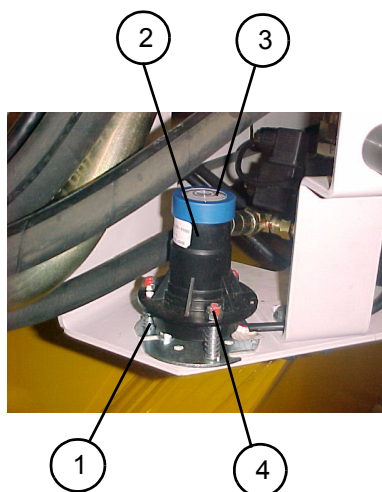

HA16/18PX nouvelle génération
HA46/51JRT New Design

 **Caution!**
The buzzer should be audible from the basket.

Sheet C040	CORRECTIVE MAINTENANCE SHEET	Folio 1/1
	CHANGING THE HORN	

 **Caution!**
Do not use the machine during maintenance operations.

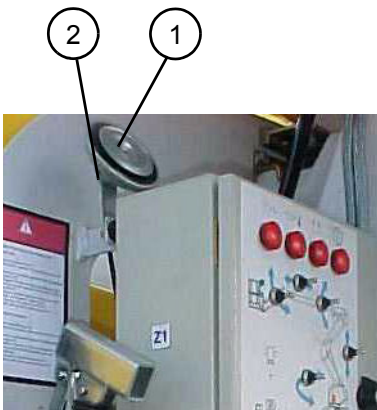

1 - Preliminary operations

- Switch off electric power (see § 6.4, page 32).

2 - Removing the horn

- Mark and disconnect the electric connections from the horn (1).
- Remove the horn, by unscrewing the fixing bolts (2).

3 - Installing the horn

- Put the horn back into place and fix with the fixing bolt.
- Reconnect the electric connections according to the marks made during dismantling.

4 - Test

- Select the top control panel and switch on machine power.
- Put the machine back into the operational configuration.
- Activate the horn switch from the platform control panel and check that the horn sounds.

 **Caution!**
The horn should be audible from the basket.

Sheet C041	CORRECTIVE MAINTENANCE SHEET	Folio 1/1
	CHANGING THE TILT SENSOR BUZZER	

 **Caution!**
Do not use the machine during maintenance operations.

HA16/18PX - HA46/51JRT

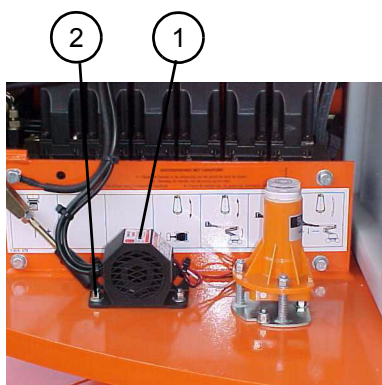

1 - Preliminary operations

- Switch off electric power (see § 6.4, page 32).

2 - Removing the buzzer

- Mark and disconnect the buzzer's electric connections (1).
- Remove the buzzer by unscrewing the fixing bolts (2).

3 - Installing the buzzer

- Put the buzzer back into place and fix with the fixing bolts.
- Reconnect the electric connections according to the marks made during dismantling.

4 - Test

- Put the machine back into the operational configuration.
- Extend the machine, tilt the tilt sensor and check that the buzzer sounds.

HA16/18PX New design
 HA46/51JRT New Design

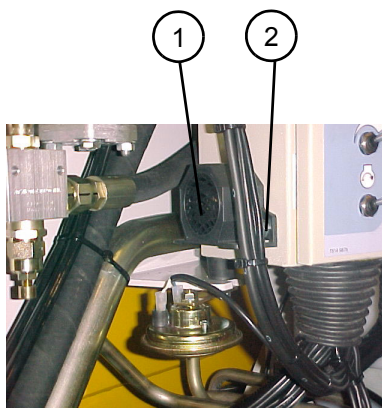

 **Caution!**
The buzzer should be audible from the basket.

Sheet C043	CORRECTIVE MAINTENANCE SHEET	Folio 1/1
	CHANGING AN ELECTRIC COMPONENT ON THE TOP CONTROL PANEL	

 **Caution!**
Do not use the machine during maintenance operations.

1 - Preliminary operations

- Put the machine in the maintenance configuration (see § 6.3, page 32).
- Switch off electric power (see § 6.4, page 32).
- Disconnect the «-» then «+» terminals of the starter battery.

2 - Removing a component from the top control panel

- Remove the closing plate (1) by removing the four fixing screws (4).
- Mark and disconnect the electric connections (3) of the component to be replaced (2).
- Remove the component.

3 - Installing a component in the top control panel

- Put a new component and seal into place on the front panel of the top control panel.

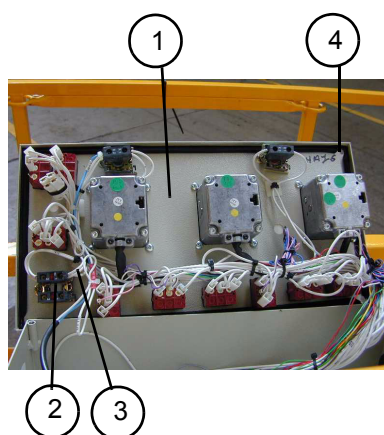

NB: *In the case of a lever switch, adjust the position of the fixing nut and counter-nut so that the switch lever's articulation pin is at the same level as the seal, to ensure tightness.*

- Reconnect the electric connections according to the marks made during dismantling.
- Fix the closing plate using the four fixing screws.
- Reconnect the « + » then « - » terminals of the battery.
- Put the machine back into the operational configuration.
- Perform the function corresponding to the replaced component to check that it works properly.

Sheet C044	CORRECTIVE MAINTENANCE SHEET	Folio 1/1
	CHANGING AN ELECTRIC COMPONENT ON THE BOTTOM CONTROL PANEL	

 **Caution!**
Do not use the machine during maintenance operations.



1 - Preliminary operations

- Put the machine in the maintenance configuration (see § 6.3, page 32).
- Switch off electric power (see § 6.4, page 32).
- Disconnect the «-» then «+» terminals to isolate the circuit.

2 - Removing a component from the bottom control panel

- Open the door of the bottom control panel (1).
- Mark and disconnect the electric connections (3) of the component to be replaced (2).
- Remove the component.

3 - Installing a component in the bottom control panel

- Put a new component and seal into place on the front panel of the bottom control panel.

NB: In the case of a lever switch, adjust the position of the fixing nut and counter-nut so that the switch lever's articulation pin is at the same level as the seal, to ensure tightness.

- Reconnect the electric connections according to the marks made during dismantling.
- Close the door of the bottom control panel.
- Reconnect the « + » then « - » terminals of the battery.

4 - Test

- Put the machine back into the operational configuration.
- Perform the function corresponding to the replaced component to check that it works properly.

Sheet C045	CORRECTIVE MAINTENANCE SHEET	Folio 1/1
	CHANGING A MANIPULATOR	

 **Caution!**
Do not use the machine during maintenance operations.

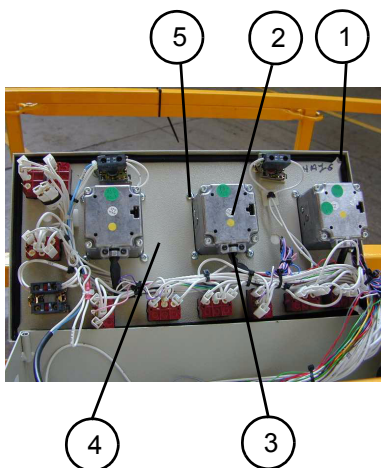

1 - Preliminary operations

- Put the machine in the maintenance configuration (see § 6.3, page 32).
- Switch off electric power (see § 6.4, page 32).
- Disconnect the «-» then «+» terminals to isolate the circuit.

2 - Removing a manipulator (2)

- Remove the upper panel (4) of the top control box by removing its fixing screws (1).
- Using cutters, remove the cable clamps from the defective manipulator wires.
- Carefully mark the positions of the different manipulator wires (3) on the top control panel connector.
- Disconnect the wires from the top control panel plug.
- Disconnect the positive wires 211 from the switches, and then the negative wire.
- Remove the fixing screws (5) from the manipulator and take the manipulator out of the box.

3 - Installing a manipulator

- Place the replacement manipulator in position and put back the fixing screws (5).
- Put back the wires (3) in the cable strand and fasten the strand using plastic clamps.
- Fit male reference contacts to the ends of the wires (3).
- Connect the wires in the plug according to the marks made during dismantling.
- Re-connect the supply wires 211 and then the negative wire.
- Put back the upper panel (4) of the box and fix using screws (1).
- Re-connect the « + » then « - » terminals of the battery.
- Put the machine back into its operational configuration.
- Make several movements controlled from the basket to test manipulator operation.

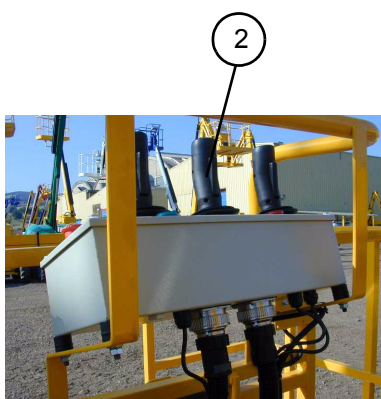

Sheet C046	CORRECTIVE MAINTENANCE SHEET	Folio 1/1
	CHANGING THE STARTER BATTERY	

 **Caution!**
Wear protective goggles and gloves for any operation on the batteries.

1 - Preliminary operations

- Put the machine in the maintenance configuration (see § 6.3, page 32).
- Switch off electric power (see § 6.4, page 32).

2 - Removing the starter battery

- Disconnect the « - » then « + » terminals (1) of the battery (3).
- Remove the fixing screws from the battery fixing tab and remove the fixing tab (2).
- Remove the battery.

3 - Installing the starter battery

- Put a new battery into place.
- Put back the fixing tab and secure with the fixing screw equipped with a new toothed washer.
- Re-connect the « + » then « - » terminals of the battery and lubricate them to improve contact.
- Put the machine back into its operational configuration.
- Start the machine to check that the battery works properly.

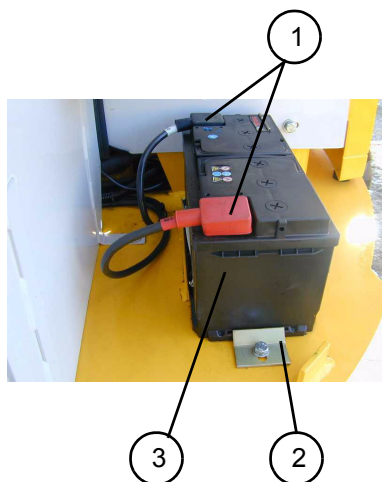

Sheet C047	CORRECTIVE MAINTENANCE SHEET	Folio 1/1
	CHANGING A COVER GAS SPRING	

 **Caution!**
Do not use the machine during maintenance operations.

HA16/18PX - HA46/51JRT

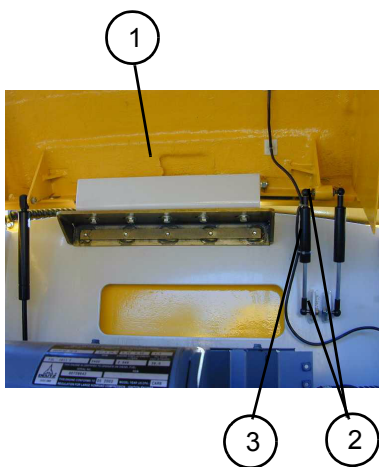

1 - Preliminary operations

- Put the machine in the maintenance configuration (see § 6.3, page 32).
- Switch off electric power (see § 6.4, page 32).

2 - Removing a gas spring

- Open the cover (1) concerned.
- Put the cover in slings.
- Remove the fixing nuts and washers (2) at both ends of the gas spring (3).

3 - Installing a gas spring

- Put a new gas spring into place and fix at both ends using the fixing nuts and washers.
- Put the machine back into the operational configuration.
- Check that the cover opens and closes correctly.

HA16/18 PX New design
 HA46/51JRT New Design

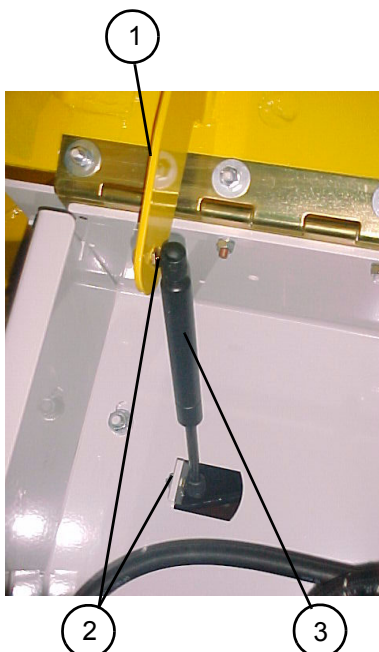

Sheet C052	CORRECTIVE MAINTENANCE SHEET	Folio 1/1
	CHANGING THE BASKET ROTATION HYDRAULIC MOTOR	

 **Caution!**
Ensure that the oil is not too hot.

 **Caution!**
Use a container to collect oil to prevent pollution of the environment.

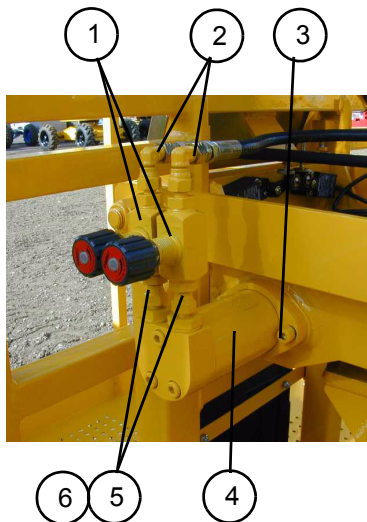

1 - Preliminary operations

- Put the machine in the maintenance configuration (see § 6.3, page 32).
- Switch off electric power (see § 6.4, page 32).

2 - Removing the hydraulic motor

- Mark and disconnect the hoses (2) from the hydraulic motor (4).

NB: *Unscrew the hoses slowly to release residual hydraulic pressure.*

- Fit caps to the hoses.
- Remove the flow limiters (1) by unscrewing the unions (5) and adapters (6).
- Remove the hydraulic motor by unscrewing its fixing screws (3).

3 - Installing the hydraulic motor

- Replace the flow limiters if necessary.
- Put a new hydraulic motor into place.
- Fix the hydraulic motor using fixing screws equipped with new grower washers.
- Screw the unions, adapters and flow limiters onto the motor.
- Reconnect the hydraulic hoses according to the marks made during dismantling (see table of tightening torque values).
- Put the machine back into the operational configuration.
- Make several platform rotation movements to purge the hydraulic circuit and adjust rotation speed using the flow limiter adjustment buttons (see § 2.3.6, page 13 Table of adjustment times).
- Check the level of the hydraulic oil tank.

Sheet C053	CORRECTIVE MAINTENANCE SHEET	Folio 1/3
	CHANGING THE BASKET	



Caution!

It is essential to put the component in slings before dismantling/re-assembling it.

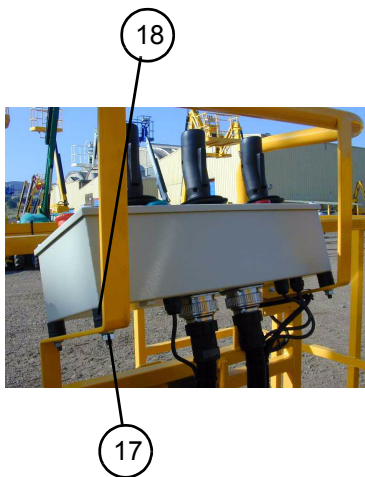

1 - Preliminary operations

- Put the machine in the maintenance configuration (see § 6.3, page 32).
- Switch off electric power (see § 6.4, page 32).
- Disconnect the « - » then « + » terminals of the starter battery.

2 - Removing the platform

- Disconnect the platform control panel electric wiring harness.
- Remove the control panel fixing screws (17).
- Remove the control panel and its silent blocks (18).
- Remove the platform's electric plug (19), if any, by unscrewing its fixing bolts.
- Put the platform in slings.
- Remove the pre-stressing stop by unscrewing the screw (1) and nut (2).

Upper part

- Remove the Nylstop nut (3) and its washer (4) on the platform side.
- Remove the stop pad (5) on the platform side.
- Remove the weighing articulation pin (6).

Lower part

- Remove the lower pivot pin (7) by removing its fixing screws (8) and washer (9).
- Remove the platform and retain the ball (10), the nylatron washer (11) and the stop (12).
- If necessary, unscrew the pre-stressing nut totally (13) as a safety measure, before performing any operation on the platform.



3 - Installing the platform

- Check the condition of the elastic parts and wearing parts, and replace if necessary (spring washers (14), collar rings (15), ring (16), nylatron washer (11), control panel silent blocks, circlips).

Lower part

- If necessary, adjust the pre-stressing system by tightening the pre-stressing nut (13), so that the washers are 108 mm high (see figure 3).
- Put the platform into place, taking care to put the ball (10), nylatron washer (11) and stop (12) in the right places.
- Lubricate the bore and put the lower pivot (7) into place. Fix using the fixing screw (8) and washer (9).

NB: *Only use lubricants recommended by the manufacturer.*

Upper part

- Lubricate then put back the weighing articulation pin (6).
- Put back the stop tab (5).
- Install the Nylstop nut (3) and its washer (4).
- Adjust the stop for the pre-stressing system by tightening the screw (1) and the nut (2).
- Put the control panel into place on its silent blocks and fix using the screws equipped with new washers.
- Reconnect the control panel wiring harness.

Sheet C053	CORRECTIVE MAINTENANCE SHEET	Folio 2/3
	CHANGING THE BASKET	

- If necessary, put the platform's electric plug back into place and fix using its fixing bolts equipped with new toothed washers.
- Reconnect the « + » then « - » terminals of the starter battery.
- Put the machine back into the operational configuration.
- Adjust the weighing contactors (see corresponding sheet).

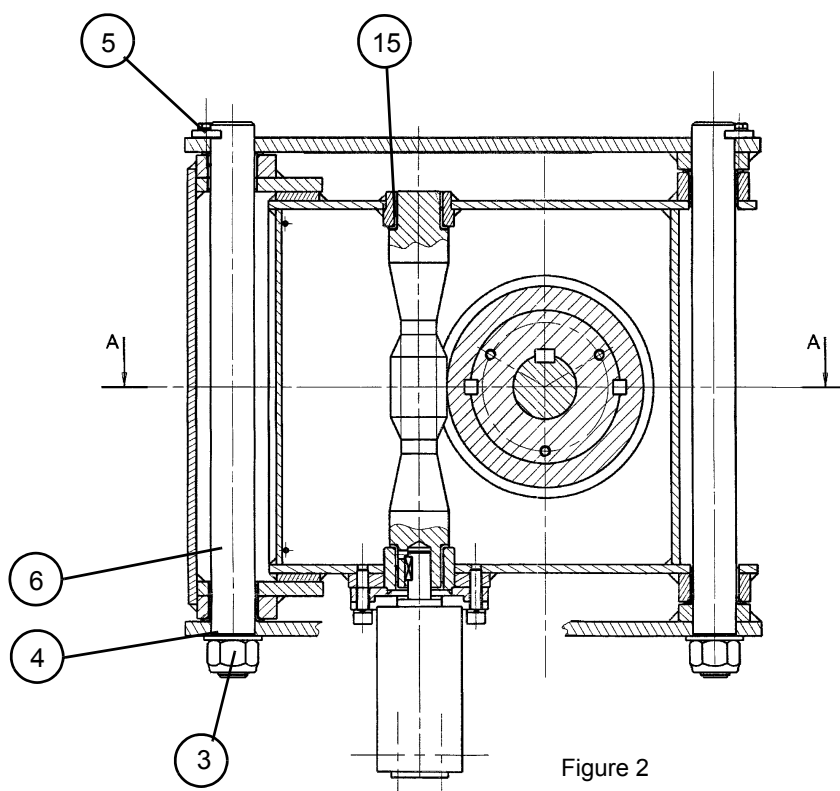
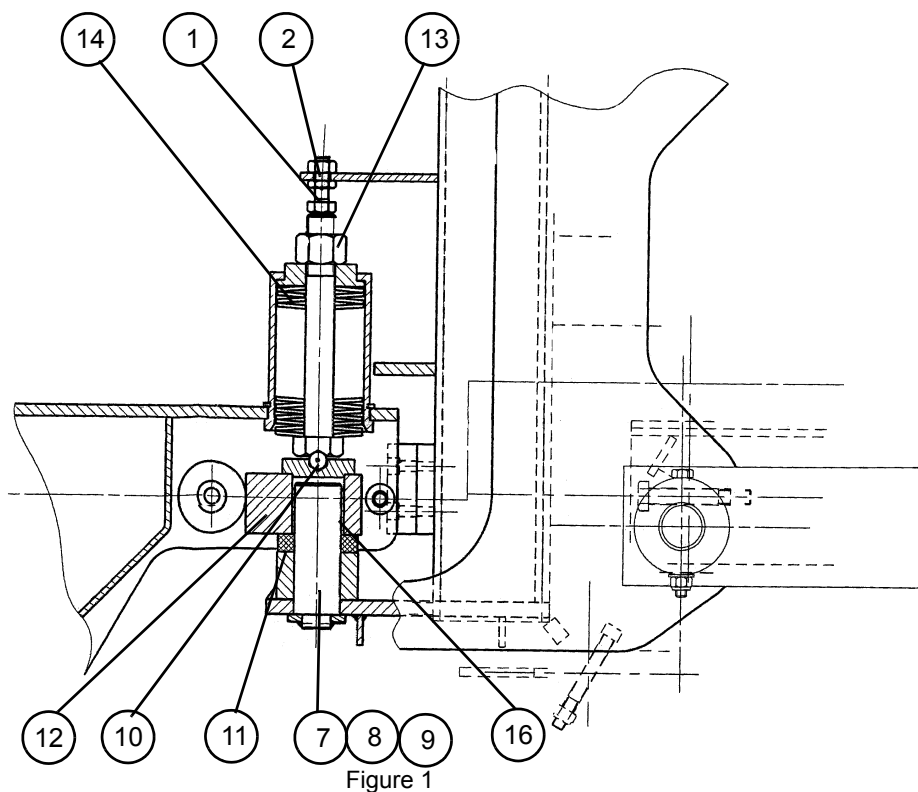

Sheet C053	CORRECTIVE MAINTENANCE SHEET	Folio 3/3
	CHANGING THE BASKET	

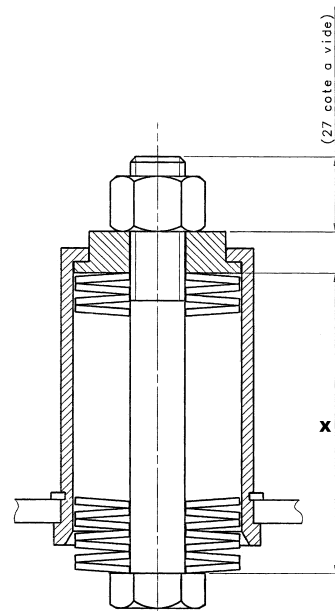

Figure 3

X =

HA16/18PX - HA46/51JRT = 108 mm / 4.25 in

H21T - HB62 = 103 mm / 4.055 in

H23T/TP - H25TP - HB68J - HB76J = 108 mm / 4.25 in

Sheet C054	CORRECTIVE MAINTENANCE SHEET	Folio 1/1
	CHANGING A WEIGHING SYSTEM ROLLING BEARING	

1 - Preliminary operations

- Put the machine in the maintenance configuration (see § 6.3, page 32).
- Switch off electric power (see § 6.4, page 32).
- Remove the basket (see corresponding sheet).

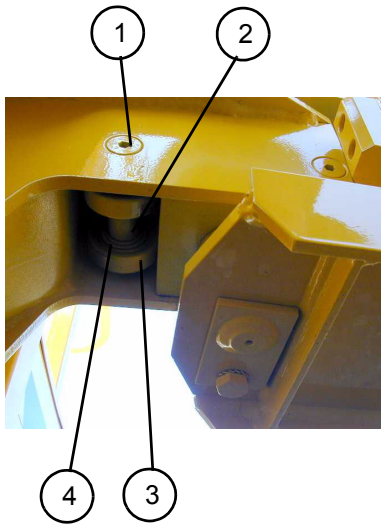

2 - Removing the rolling bearing

- Remove the screws (1) from the rolling bearing track.
- Remove the rolling bearing track (2).
- Remove the circlips (4), then the ball bearings (3).

3 - Installing the rolling bearing

- Put new rolling elements on the bearing track. Block in travel using the circlips.
- Lubricate the rolling bearings.

NB: *Only use lubricants recommended by the manufacturer.*

- Re-install the basket (see corresponding sheet).
- Put the machine back in the operational configuration.

Sheet C056	CORRECTIVE MAINTENANCE SHEET	Folio 1/1
	CHANGING THE HYDRAULIC FILTER	

 **Caution!**
 Ensure that the oil is not too hot.

 **Caution!**
 Use a container to collect oil to prevent pollution of the environment.

1 - Preliminary operations

- Put the machine in the maintenance configuration (see § 6.3, page 32).
- Switch off electric power (see § 6.4, page 32).
- Close the shut-off valve, if any. Otherwise, empty the hydraulic tank.

2 - Removing the hydraulic filter

- Disconnect the hydraulic filter hoses (1).

NB: Unscrew the hoses slowly to release residual hydraulic pressure.

- Fit caps to the hoses.
- Unscrew the fixing screws (2) and remove the hydraulic filter.
- Remove the two connectors (3) from the hydraulic filter.

3 - Installing the hydraulic filter

- Install the two connectors on a new hydraulic filter (see the table of tightening torque values).
- Put the equipped hydraulic filter back into place, respecting the oil flow direction and fix using the fixing screws.
- Reconnect the hydraulic hoses.
- Put the machine back into the operational configuration.
- Make several lifting cycles to purge the hydraulic circuit.



HA16/18PX - HA46/51JRT



H14/16TPX - HB40/44J

	CORRECTIVE MAINTENANCE SHEET	Folio 2/2

Sheet C059	CORRECTIVE MAINTENANCE SHEET	Folio 1/1
	CHANGING A COIL	

1 - Preliminary operations

- Put the machine in the maintenance configuration (see § 6.3, page 32).
- Switch off electric power (see § 6.4, page 32).

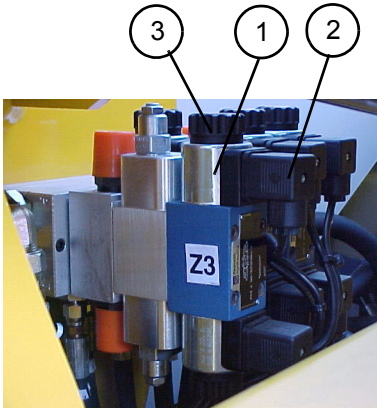

2 - Removing a coil

- Disconnect the electric connector (2) from the coil concerned.
- Unscrew the nut (3) and remove the coil (1).

3 - Installing a coil

- Put a new coil into place (1) and fix with the nut (3).
- Reconnect the electric connector (2) to the coil.
- Put the machine back into the operational configuration.
- Check proper operation by making the movement corresponding to the replaced coil.

Sheet C062	CORRECTIVE MAINTENANCE SHEET	Folio 1/2
	CHANGING A RELAY	

1 - Preliminary operations

- Put the machine in the maintenance configuration (see § 6.3, page 32).
- Switch off electric power (see § 6.4, page 32).
- Disconnect the « - » then « + » terminals of the starter battery.

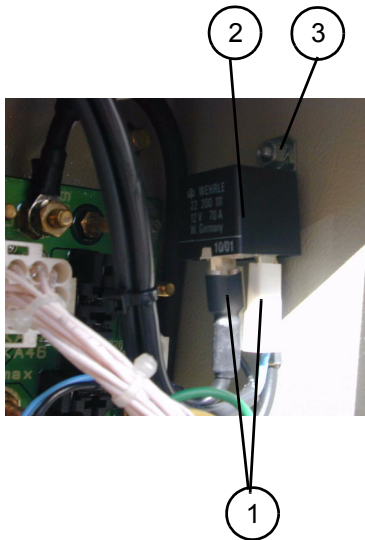

2 - Removing a relay

- Open the turntable electric box.
- Mark and disconnect the electric connections (1) of the relay (2).
- Remove the relay by removing the fixing bolt (3).

3 - Installing a relay

- Put a new relay into place and fix using its bolt equipped with a new grower washer.
- Reconnect the electric connections according to the marks made during dismantling.
- Close the turntable box.
- Reconnect the « + » then « - » terminals of the starter battery.
- Put the machine back into the operational configuration.

Sheet C062	CORRECTIVE MAINTENANCE SHEET	Folio 2/2
	CHANGING A RELAY	

Sheet C063	CORRECTIVE MAINTENANCE SHEET	Folio 1/1
	CHANGING THE PRINTED CIRCUIT	

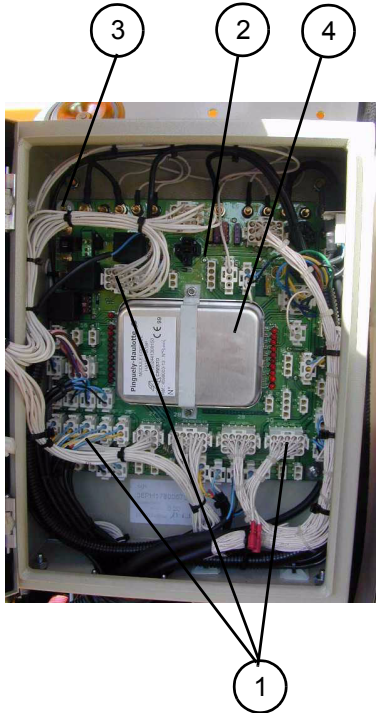

1 - Preliminary operations

- Put the machine in the maintenance configuration (see § 6.3, page 32).
- Switch off electric power (see § 6.4, page 32).
- Disconnect the « - » then « + » terminals of the starter battery.

2 - Removing the printed circuit

- Open the turntable electric box.
- Carefully mark and disconnect all the electric connections (1) of the printed circuit (2).
- Remove the U1 electronic module (4) (see corresponding sheet)
- Remove the bolts (3) fixing the board to the box and their sealing washers.
- Remove the printed circuit and silent-blocks equipping the fixing bolts.

3 - Installing the printed circuit

- Put a new printed circuit into place and fix using the bolts equipped with silent blocks, sealing rings and new toothed washers.
- Install the U1 electronic module (see corresponding sheet).
- Reconnect the electric connections according to the marks made during dismantling.
- Close the turntable box.
- Reconnect the « + » then « - » terminals of the starter battery.
- Put the machine back into the operational configuration.
- Test the printed circuit.

4 - Testing the printed circuit

- Perform the computer operating test (see «changing the U1 electronic module» sheet).

Sheet C064	CORRECTIVE MAINTENANCE SHEET	Folio 1/1
	CHANGING THE FAIL-SAFE PEDAL	

1 - Preliminary operations

- Put the machine in the maintenance configuration (see § 6.3, page 32).
- Switch off electric power (see § 6.4, page 32).
- Disconnect the « - » then « + » terminals of the starter battery.



2 - Removing the fail-safe pedal

- Open the platform electric box.
- Mark and disconnect the electric connections (1) of the fail-safe pedal (2) in the box.
- Mark the pedal cabling path (1) along the vertical platform parts and then cut the fixing collars (3).
- Remove the pedal by removing the pedal's fixing bolts (4) and their washers.

3 - Installing the fail-safe pedal

- Put a new pedal into place and fix using the bolts and their washers.
- Reconnect the electric connections in the box, according to the marks made during dismantling.
- Close the platform box.
- Fix the electric cable to the vertical platform parts using collars.
- Reconnect the « + » then « - » terminals of the starter battery.
- Put the machine back into the operational configuration.
- Check that movements from the platform are possible only if the fail-safe pedal is pressed.

Sheet C067	CORRECTIVE MAINTENANCE SHEET	Folio 1/1
	CHANGING AN ELECTROVALVE	

 **Caution!**
Ensure that the oil is not too hot.

 **Caution!**
Use a container to collect oil to prevent pollution of the environment.

1 - Preliminary operations

- Put the machine in the maintenance configuration (see § 6.3, page 32).
- Switch off electric power (see § 6.4, page 32).

2 - Removing an electrovalve

- Mark and disconnect the electric connections(1) of the coils.
- Mark the installation position of the electrovalve on the block.
- Unscrew the four fixing screws (3) of the electrovalve (2) and remove.

3 - Installing an electrovalve

- Put a new electrovalve equipped with its seals into place and fix using the 4 screws, in the position of the electrovalve on the block. Tighten to the recommended torque (see § 2.3, page 10).
- Reconnect the electrovalve's electric connections, according to the marks made during dismantling.
- Put the machine back into the operational configuration.
- Make several movement cycles using the replaced electrovalve to purge the hydraulic circuit.
- Check the level of the hydraulic oil tank.

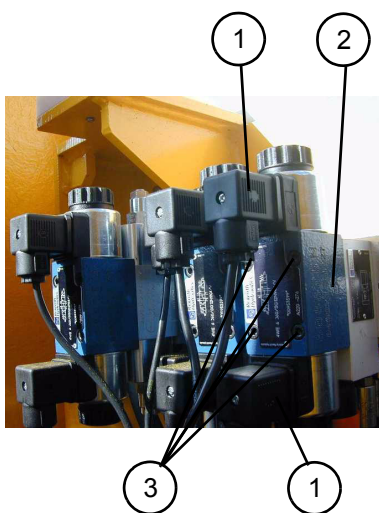

Sheet C079	CORRECTIVE MAINTENANCE SHEET	Folio 1/1
	CHANGING A FLOW SEPARATOR	



Caution!
Ensure that the oil is not too hot.



Caution!
Use a container to collect oil to prevent pollution of the environment.

1 - Preliminary operations

- Put the machine in the maintenance configuration (see § 6.3, page 32).
- Switch off electric power (see § 6.4, page 32).

2 - Removing a flow separator

- Remove the flow separator (1) by unscrewing it.

3 - Installing a flow separator

- Screw a new flow separator, whose characteristics correspond to the machine in question, into the hydraulic block.
- Tighten to the recommended torque:
 - Flow separator ref. FDC1-10: 47 to 54 Nm. (34 to 39.8 lb.ft)
 - Flow separator ref. FDC1-16: 108 to 122 Nm (79.6 to 89.9 lb.ft).
- Put the machine back into the operational configuration.
- Make several movements using the replaced flow separator to purge the circuit.
- Check that the corresponding movement is made correctly.

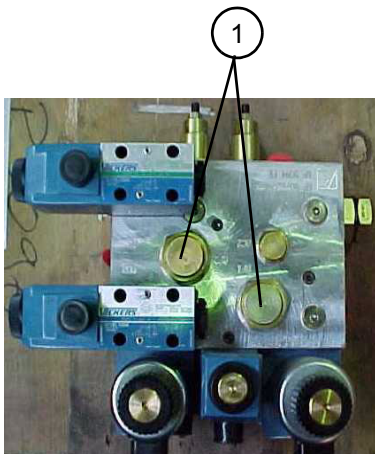

Sheet C082	CORRECTIVE MAINTENANCE SHEET	Folio 1/1
	CHANGING A BALANCING VALVE FOR THE COMPENSATION FUNCTION	



Caution!

Ensure that the oil is not too hot.



Caution!

Use a container to collect oil to prevent pollution of the environment.



Caution!

Balancing valves are safety elements. They are calibrated in the plant and must not be re-adjusted.

1 - Preliminary operations

- Put the machine in the maintenance configuration (see § 6.3, page 32).
- Switch off electric power (see § 6.4, page 32).

2 - Removing a balancing valve

- Remove the balancing valve (1) by unscrewing it.

3 - Installing a balancing valve

- Screw a new balancing valve, whose characteristics correspond to the machine in question, into the hydraulic block. Tighten to a torque of 45 to 50 Nm (33 to 36.7 lb.ft).
- Put the machine back into the operational configuration.
- Make several movements using the replaced balancing valve to purge the circuit.
- Check that the corresponding movement is made correctly.

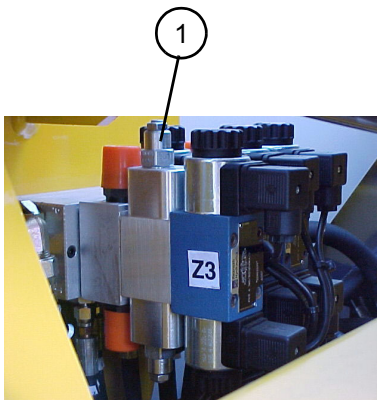

Sheet C083	CORRECTIVE MAINTENANCE SHEET	Folio 1/1
	CHANGING A DOUBLE FLOW LIMITER FOR THE COMPENSATION FUNCTION	

 **Caution!**
Ensure that the oil is not too hot.

 **Caution!**
Use a container to collect oil to prevent pollution of the environment.

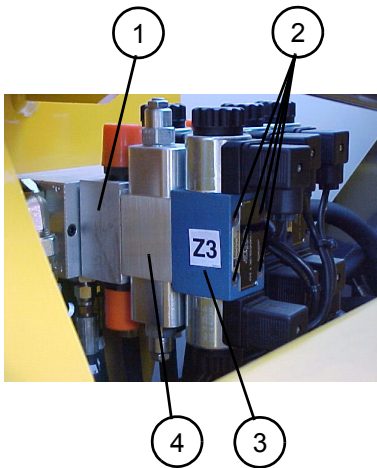

1 - Preliminary operations

- Put the machine in the maintenance configuration (see § 6.3, page 32).
- Switch off electric power (see § 6.4, page 32).

2 - Removing a double flow limiter (1)

- Mark the installation position of the electro distributor, balancing valve and double flow limiter.
- Remove the 4 fixing screws (2), then take out the electrovalve (3) + balancing valve (4) + double flow limiter (1) assembly.
- Remove the double flow limiter (1).

3 - Installing the double flow limiter

- Replace the seals and put into place on the hydraulic block a new flow limiter (1), whose characteristics correspond to the machine in question, then the balancing valve (4) and the electrovalve (3).
- Fix the assembly with the 4 fixing screws (2). Tighten to the recommended torque (see corresponding chapter).
- Put the machine back into the operational configuration.
- Make several movements using the replaced double flow limiter to purge the circuit.
- Adjust compensation up and down speeds (see corresponding chapter).
- Check that the corresponding movement is made correctly.

Sheet C085	CORRECTIVE MAINTENANCE SHEET	Folio 1/2
	CHANGING A STEERING PIVOT ON A NON-DRIVE WHEEL	



Caution!

Ensure that the oil is not too hot.



Caution!

Use a container to collect oil to prevent pollution of the environment.



Caution!

It is essential to put the component in slings before dismantling/re-assembling it.

1 - Preliminary operations

- Put the machine in the maintenance configuration (see § 6.3 -).
- Switch off electric power (see § 6.4 -).
- Remove the wheel corresponding to the element to be removed (see corresponding sheet).

2 - Removing the bearings (if necessary)

- Remove the cap (10).
- Remove the counter-nut (11), brake washer (12) and nut (13).
- Remove the hub (14) of the pivot (1).
- Remove the bearings (16).
- Remove the seal (15).

3 - Removing a pivot (see figure 1)

- Place a wedge under the steering pivot (1).
- Remove the fixing screw (2) from the steering clevis pin.
- Remove the steering clevis pin (3).
- Remove the two screws (4) from the two caps on the pivot pin and remove the two caps (5).
- Take the Mécanindus pin from each pivot pin (6), and remove the pivot pin and support washer (7).
- Remove the steering pivot (1).

4 - Installing a pivot

- Put the steering pivot into place.
- Replace pins, lubricators and support washers if necessary.
- Put back the support washers and pivot pins, and block using new Mécanindus pins.
- Put back the pivot pin caps and fix using fixing screws and washers.
- Adjust wheel alignment if necessary:
 - slacken the counter-nut (8),
 - screw or unscrew the clevis (9) to adjust the length of the steering bar.
 - tighten the counter-nut (8).
- Put back the steering clevis pin and fix using the screw equipped with a new grower washer.

NB: *When re-installing the pins, take the measures necessary to avoid damaging the pins, rings and bores.*

5 - Installing the bearings (if applicable)

- Lubricate the bearings and pivot pin.

NB: *Only use lubricants recommended by the manufacturer.*

- Install a new seal (15).
- Install the bearings (16) on the hub (14).
- Install the hub (14) on the pivot (1).
- Install the nut (13).
- Block the nut (13) until the wheel turns with difficulty and turn back one quarter turn.
- Install the brake washer (12) and counter-nut (11).
- Block the counter-nut (11), then raise the wings of the brake washer.
- Put back the cap (10).

6 - Additional operations

- Put back the wheel (see corresponding sheet).
- Put the machine back in the operational configuration.
- Make several travel movements to check correct operation.
- Lubricate the pins with the lubricators.

Sheet C085	CORRECTIVE MAINTENANCE SHEET	Folio 2/2
	CHANGING A STEERING PIVOT ON A NON-DRIVE WHEEL	



A - A

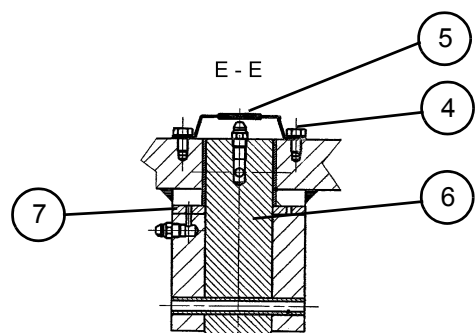
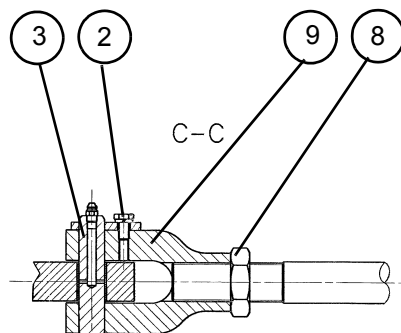
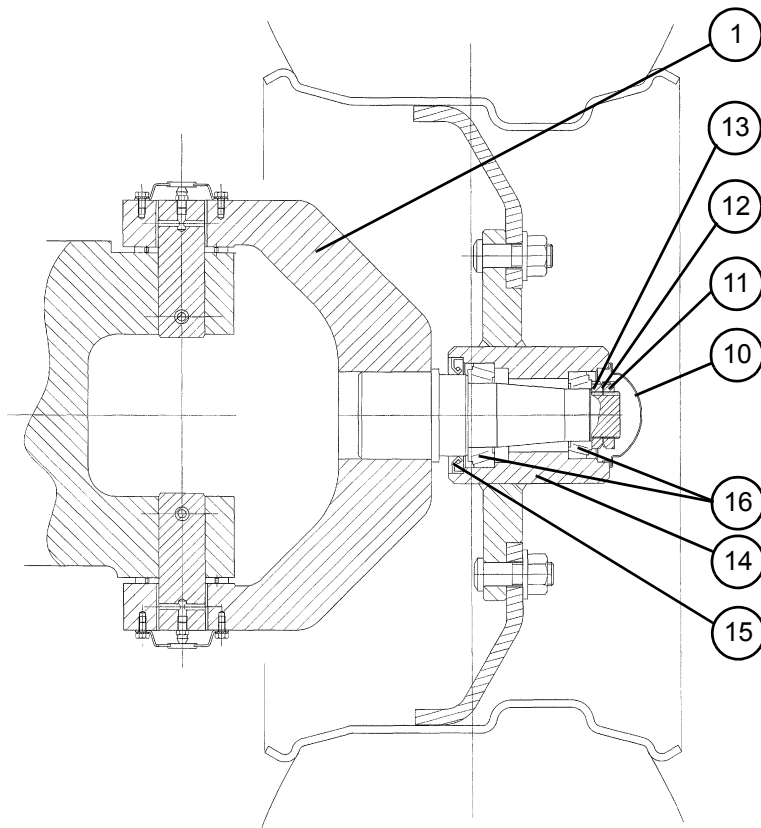

Sheet C086	CORRECTIVE MAINTENANCE SHEET	Folio 1/2
	DISMANTLING AND RE-ASSEMBLING THE STEERING SYSTEM	

 **Caution!**
Ensure that the oil is not too hot.

 **Caution!**
Use a container to collect oil to prevent pollution of the environment.

 **Caution!**
It is essential to put the component in slings before dismantling/re-assembling it.

1 - Preliminary operations

- Put the machine in the maintenance configuration (see § 6.3 -).
- Switch off electric power (see § 6.4 -).

2 - Removing a steering bar

- Remove the fixing screw (1) from the two steering clevis pins (2).
- Remove the two steering clevis pins (2).
- Unscrew the counter-nut (11).
- Remove the steering bar (3).

NB: Repeat the operation (2) for the other side.

3 - Removing the steering lever (section B-B)

- Remove the Nylstop nut (4) and the washer (5) from the cylinder fastening pin.
- Remove the cylinder fastening pin (6).
- Remove the male clevis (12).
- Remove the screws and washers (13/14) then the central steering pin (8).
- Remove the steering lever (9).

4 - Installing the steering lever

NB: When re-installing the pins, take the measures necessary to avoid damaging the pins, rings and bores.

- Replace the pins and lubricators if necessary.
- Put the steering lever into place.
- Put back the central steering pin, then the screws and new washers (13/14)
- Put back the male clevis and fix with its fixing screw equipped with a new washer.
- Put back the cylinder fastening pin and fix with a new Nylstop nut and its washer.

5 - Installing a steering bar

- Replace the pins and lubricators if necessary.
- Put the steering bar into place, performing the removal operations in reverse order.
- Adjust wheel alignment if necessary:
 - slacken the counter-nut (10) on the steering bar,
 - screw or unscrew the clevis (11) to adjust the length of the steering bar.
 - tighten the counter-nut (10).
- Put back the two steering clevis pins.
- Put back the fixing screws of the two steering clevis pins.

6 - Additional operations

- Put the machine back in the operational configuration.
- Lubricate the pins with lubricators.

Sheet C086	CORRECTIVE MAINTENANCE SHEET	Folio 2/2
	DISMANTLING AND RE-ASSEMBLING THE STEERING SYSTEM	

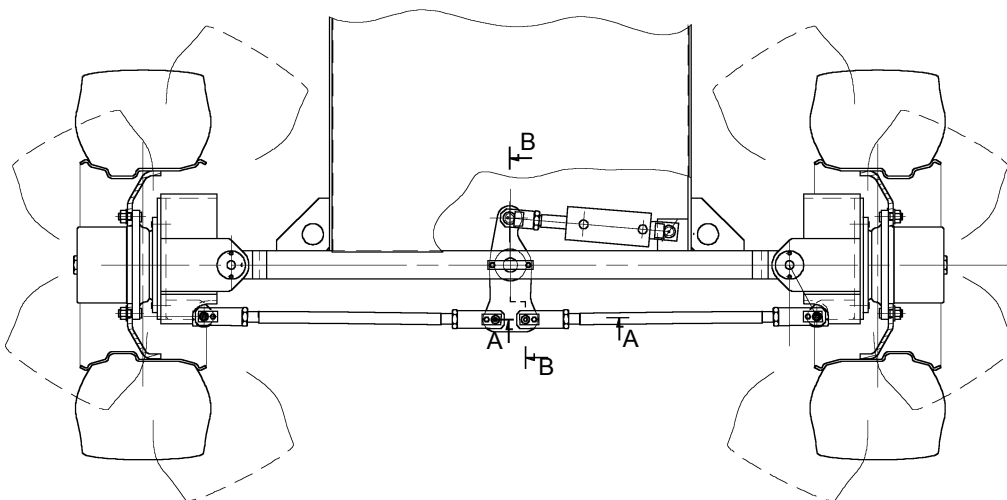
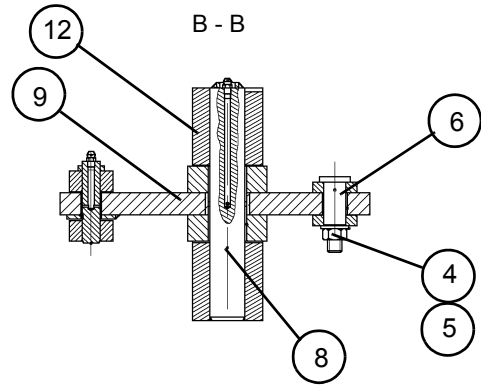
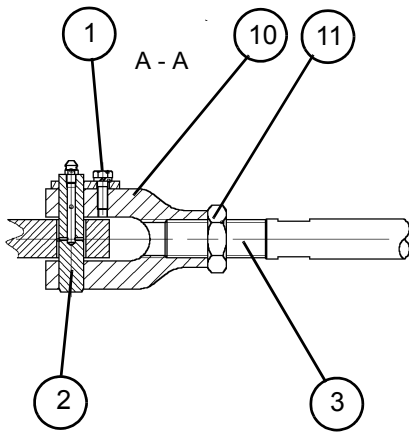
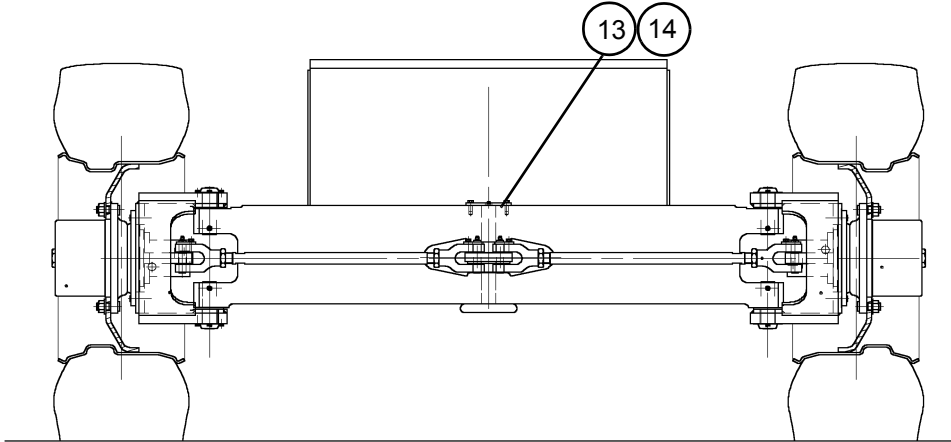

Sheet C087	CORRECTIVE MAINTENANCE SHEET	Folio 1/1
	CHANGING THE STEERING CYLINDER	



Caution!

Ensure that the oil is not too hot.



Caution!

Use a container to collect oil to prevent pollution of the environment.



Caution!

It is essential to put the component in slings before dismantling/re-assembling it..

1 - Preliminary operations

- Put the machine in the maintenance configuration (see § 6.3 -).
- Switch off electric power (see § 6.4 -).

2 - Removing the steering cylinder

- Open the upper cover of the chassis.
- Mark and disconnect the two hoses (2) of the steering cylinder (1).

NB: *Unscrew the hoses slowly to release residual hydraulic pressure.*

- Put caps on the hoses.
- Put the cylinder in slings.
- Remove the Nylstop nuts (4) then remove the two fastening pins (3) from the steering cylinder.
- Remove the steering cylinder.

3 - Installing the steering cylinder

- Put a new steering cylinder into place.
- Put back the fastening pins and fix using new Nylstop nuts and washers.
- Reconnect the hydraulic hoses, according to the marks made during dismantling.
- Check that there is sufficient oil in the hydraulic tank.
- Put the machine back into the operational configuration.
- Make several steering movements to purge the hydraulic circuit.
- Check the level of the hydraulic oil tank.

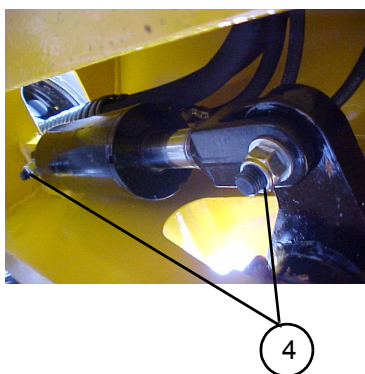
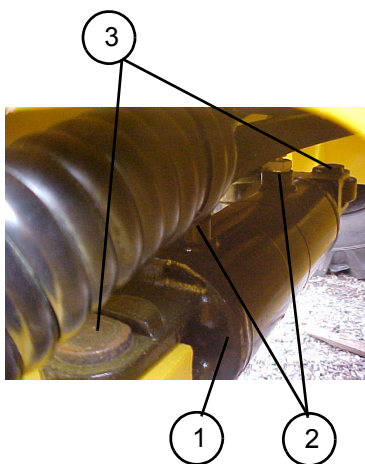

Sheet C087	CORRECTIVE MAINTENANCE SHEET	Folio 2/2
	CHANGING THE STEERING CYLINDER	

Sheet C091	CORRECTIVE MAINTENANCE SHEET	Folio 1/2
	CHANGING THE HYDRAULIC PUMP	



Caution!

Ensure that the oil is not too hot.



Caution!

Close the shut-off valve if any, otherwise, empty the hydraulic oil tank.



Caution!

Use a container to collect oil to prevent pollution of the environment.



Caution!

It is essential to put the component in slings before dismantling/re-assembling it.

1 - Preliminary operations

- Put the machine in the maintenance configuration (see § 6.3 -).
- Switch off electric power (see § 6.4 -).
- Close the shut-off valve if any, otherwise, empty the hydraulic oil tank.

2 - Removing the hydraulic pump

- Mark and disconnect the pump hoses (1).

NB: Unscrew the hoses slowly to release residual hydraulic pressure.

- Put caps on the hoses.
- Remove the hydraulic unions (4) screwed on the pump.
- Remove the screws and washers (2) fixing the pump to the motor flange (3), then remove the pump (5).
- Remove the split spined hub (6) by unscrewing its tightening screw (7).
- Discard the O-rings.

3 - Installing the hydraulic pump

- Equip the unions with new O-rings.
- Screw the hydraulic unions on the pump.
- Check that the circlips and spacer are in good condition and in position inside the split spined hub.
- Lubricate then fit the split spined hub onto a new pump, until the pump shaft comes up against the spacer. Tighten to a torque of 83 N.m (61.21 lb.ft).
- Coat the hub's tightening screws with normal blue loctite 243
- Install the pump on the flange and fix using fixing screws previously coated with normal blue loctite 243 and equipped with new grower washers. Tighten to a torque of 86 N.m (63.43 lb.ft).
- Reconnect the hydraulic hoses according to the marks made during dismantling.
- Open the shut-off valve, if any.
- Check the level of the hydraulic tank and fill if necessary.
- Before starting, fill the pump pan with hydraulic oil (hole L engraved on the pump).

4 - Additional operations

- Put the machine back in the operational configuration.
- Make several extension movements to purge the hydraulic circuit.
- Check the level of the hydraulic oil tank.
- Adjust pump flow, the load sensing pressure limiter and the main pressure limiter (see corresponding sheet).

Sheet C091	CORRECTIVE MAINTENANCE SHEET	Folio 2/2
	CHANGING THE HYDRAULIC PUMP	

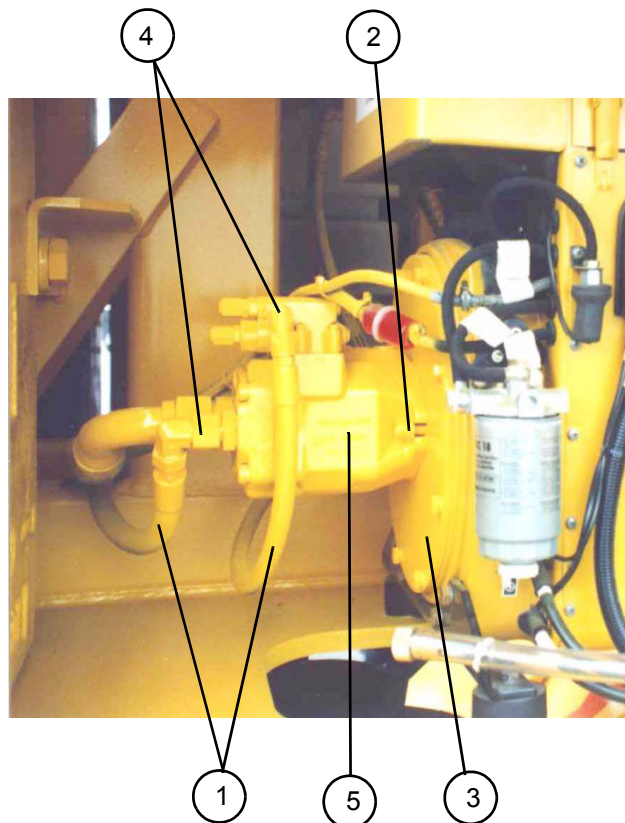
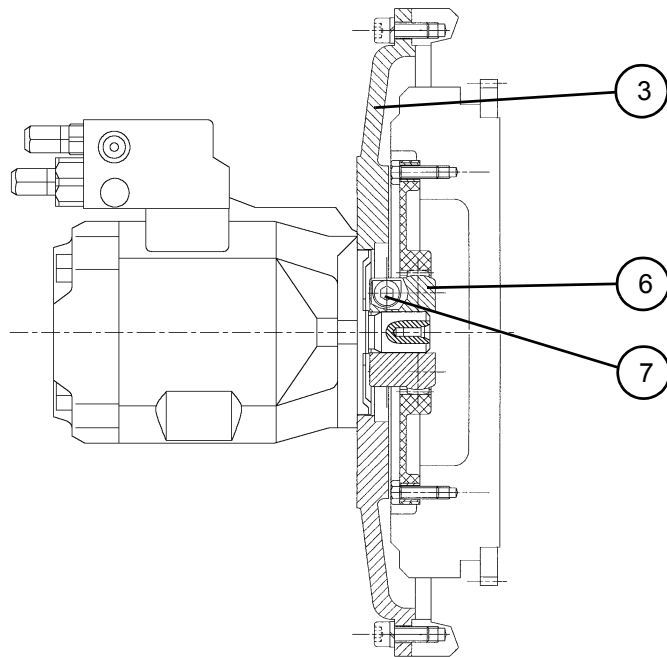

Sheet C092	CORRECTIVE MAINTENANCE SHEET	Folio 1/2
	CHANGING THE HYDRAULIC BLOCK (TRAVEL / ON-OFF MOVEMENT / STEERING)	

 **Caution!**
Ensure that the oil is not too hot.

 **Caution!**
Use a container to collect oil to prevent pollution of the environment.

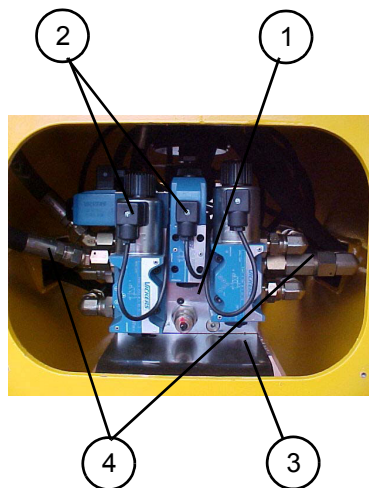

1 - Preliminary operations

- Put the machine in the maintenance configuration (see § 6.3 -).
- Switch off electric power (see § 6.4 -).

2 - Removing the hydraulic block

- Remove the chassis inspection flap enabling access to the hydraulic block.
- Mark and disconnect the electric connections (2) of the hydraulic block (1).
- Mark and disconnect the block's hoses (4).

NB: *Unscrew the hoses slowly to release residual hydraulic pressure.*

- Put caps on the hoses.
- Place a wedge under the hydraulic block if necessary.
- Remove the hydraulic block by removing the fixing screws and washers (3).

3 - Installing the hydraulic block

- Put the hydraulic block into place and fix using screws equipped with new toothed washers.
- Reconnect the hydraulic hoses according to the marks made during dismantling.
- Reconnect the electric connections of the hydraulic block, according to the marks made during dismantling.
- Put the machine back in the operational configuration.
- Make several movements using the replaced hydraulic block to purge the hydraulic circuit.
- Check the level of the hydraulic oil tank.

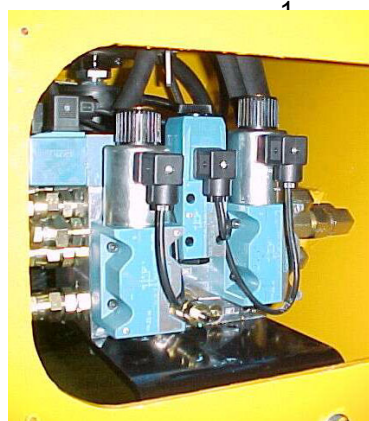

Travel



On/off movement

Sheet C092	CORRECTIVE MAINTENANCE SHEET	Folio 2/2
	CHANGING THE HYDRAULIC BLOCK (TRAVEL / ON-OFF MOVEMENT / STEERING)	

Sheet C093	CORRECTIVE MAINTENANCE SHEET	Folio 1/2
	CHANGING THE DISTRIBUTION HYDRAULIC BLOCK	

 **Caution!**
Ensure that the oil is not too hot.

 **Caution!**
Use a container to collect oil to prevent pollution of the environment.

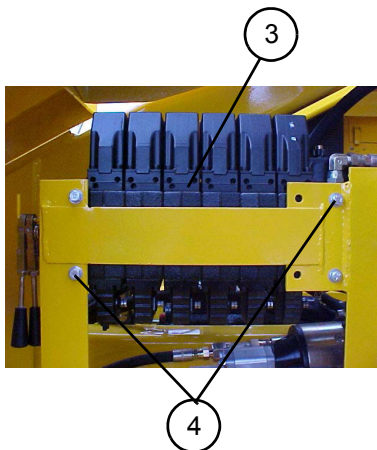

1 - Preliminary operations

- Put the machine in the maintenance configuration (see § 6.3 -).
- Switch off electric power (see § 6.4 -).

2 - Removing the distribution hydraulic block

- Mark and disconnect the electric connections (1) of the hydraulic block (3).
- Mark and disconnect the block's hoses (2).

NB: *Unscrew the hoses slowly to release residual hydraulic pressure.*

- Put caps on the hoses.
- Put the hydraulic block in slings.
- Remove the fixing screws and washers (4) from the hydraulic block.
- Take out the block from the top of the turntable.
- Dismantle the hydraulic block to change one of its elements, if necessary (see corresponding sheet).

3 - Installing the distribution hydraulic block

- If the distribution block installed is new, fit the new block with the unions retained from the old one but replace the O-rings. Tighten to the recommended torque (see concerned chapter).
- Put the hydraulic block into place and fix with screws, equipped with new grower washers.
- Reconnect the hydraulic hoses according to the marks made during dismantling. Tighten to the recommended torque (see chapter concerned).
- Reconnect the hydraulic block's electric connections, according to the marks made during dismantling.
- Put the machine back in the operational configuration.
- Check that there is sufficient oil in the hydraulic tank.
- Make several lifting, travel, steering and turntable rotation movements to purge the hydraulic circuit and test block operation.
- Check the level of the hydraulic oil tank.

Sheet C093	CORRECTIVE MAINTENANCE SHEET	Folio 2/2
	CHANGING THE DISTRIBUTION HYDRAULIC BLOCK	

Sheet C094	CORRECTIVE MAINTENANCE SHEET	Folio 1/1
	INTRINSIC DISMANTLING / RE-ASSEMBLY OF THE DISTRIBUTION HYDRAULIC BLOCK	



Caution!

Ensure that the oil is not too hot.



Caution!

Use a container to collect oil to prevent pollution of the environment.

1 - Preliminary operations

- Remove the distribution hydraulic block (see corresponding sheet).

2 - Dismantling the distribution hydraulic block (1)

- Mark the assembly position of the input plate, input module, distribution elements and closing plate.
- If necessary, remove the control units (see corresponding sheet).
- Remove the fixing nuts and 3 tie rods (2) then separate the elements.

3 - Re-assembling the distribution hydraulic block

- Replace the O-ring seals.
- If necessary, put back the control units (see corresponding sheet).
- Remount the input plate, input module, distribution elements and closing plate.
- Put back the fixing nuts and 3 tie rods (2). Tighten to 2.2 daN.m (15.91 lb.ft).
- Put back the distribution hydraulic block (see corresponding sheet).
- Check that there is sufficient oil in the hydraulic tank.
- Put the machine back in the operational configuration.
- Make several lifting, travel, steering and turntable rotation movements to purge the hydraulic circuit.
- Check the level of the hydraulic oil tank.

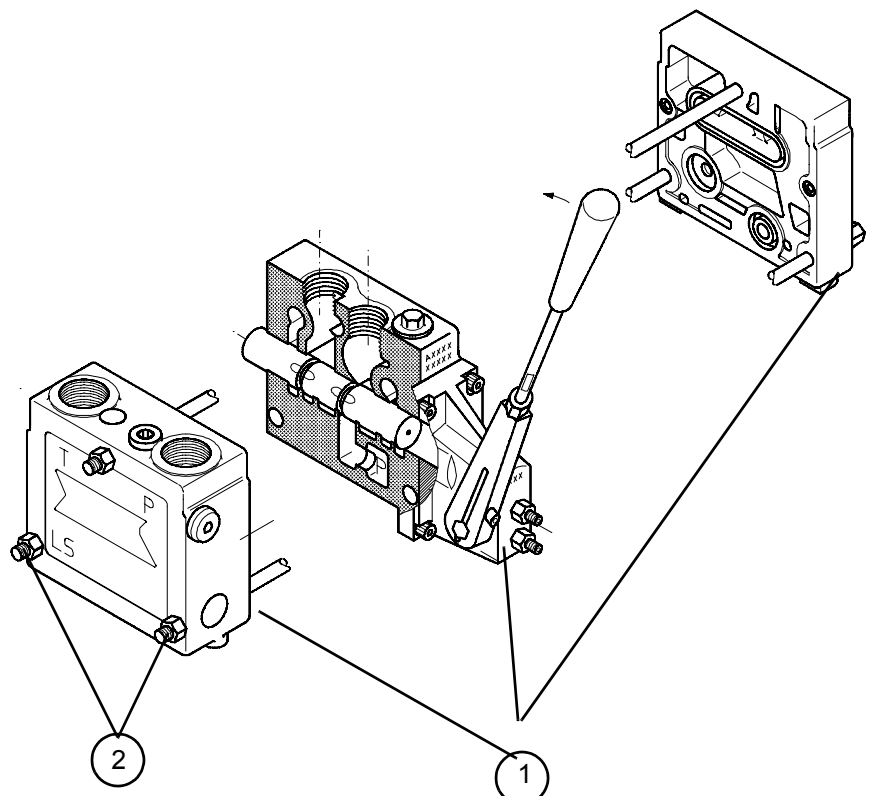

Sheet C097	CORRECTIVE MAINTENANCE SHEET	Folio 1/1
	CHANGING A TURNTABLE COVER	

 **Caution!**
Do not use the machine during maintenance operations.

1 - Preliminary operations

- Put the machine in the maintenance configuration (see § 6.3 -).
- Switch off electric power (see § 6.4 -).

2 - Removing a cover

- Open the relevant cover (1).
- Put the cover in slings.
- Remove the nuts and washers (3) fixing the gas springs to the connecting rods (2) supporting the cover.
- Remove the bolts (5) and (6) fixing the cover (1) to the two hinges (4).
- Retain the cover support connecting rods (2).
- Remove the cover.

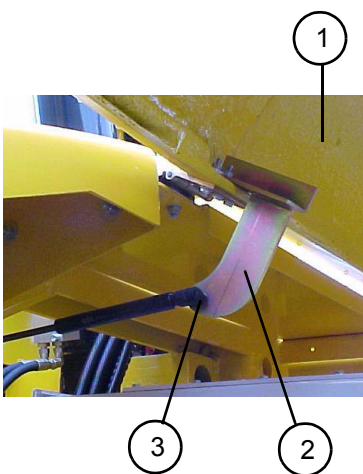

3 - Installing a cover

- Position a new cover, and fix to the hinges (4) with screws (5).
- Put back the cover support connecting rods using their fixing screws (6).
- Fix the gas springs to the cover connecting rods (2) using nuts and washers (3).
- Check that the cover opens and closes properly.
- If necessary, adjust the cover using screws (4) and (5).
- Put the machine back in the operational configuration.

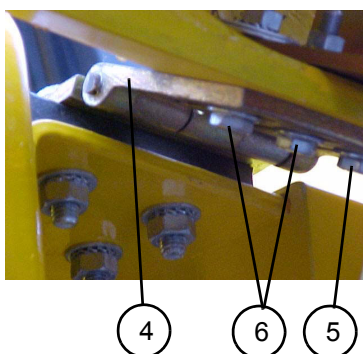

Sheet C098	CORRECTIVE MAINTENANCE SHEET	Folio 1/2
	CHANGING THE THERMAL MOTOR	

 **Caution!**
Leave the motor and exhaust to cool sufficiently before performing any maintenance operation on these elements.

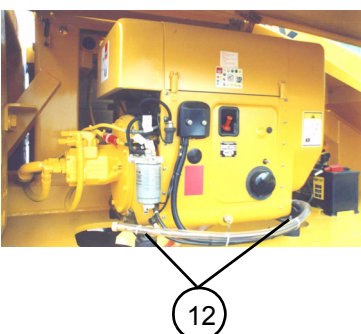
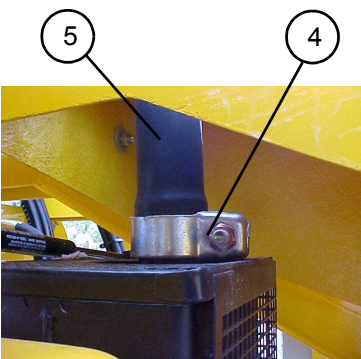

1 - Preliminary operations

- Put the machine in the maintenance configuration (see § 6.3 -).
- Switch off electric power (see § 6.4 -).
- Disconnect the « - » then « + » terminals of the starter battery.
- Remove the cover on the motor side (see corresponding sheet).

2 - Removing the connections

- On the motor, disconnect the battery connection wires (1).
- Disconnect the motor's electric connections (2) and free the trunking from its plastic collars.
- Disconnect the fuel incoming (3) and outgoing pipes.
- Remove the fixing collar (4) on the exhaust.
- Remove the extension tube at exhaust exit (5).
- Remove the motor backflow duct (6).

3 - Removing the coupling

- Remove the hydraulic pump (7) (see corresponding sheet).
- Remove the screws (8) fixing the motor flap flange (9) and remove the flange.
- Remove the fixing screws (10) from the coupling plate (11) and remove the plate.

4 - Removing the thermal motor

- Put the motor in slings according to the instructions in the motor manufacturer's manual.
- Remove the motor's 4 fixing screws and nuts (12) and remove the motor.

5 - Installing the thermal motor

- Check the condition of the 4 silent blocks, and replace if necessary.
- Put the thermal motor into place and fix with the 4 fixing screws and new nylstop nuts.

6 - Installing the coupling

- Put the coupling plate (11) into place and fix with the fixing screws, previously coated with normal blue loctite 243. Tighten to a torque of 25 N.m (18.43 lb.ft).
- Put the motor flap flange into place and fix with the screws equipped with new grower washers. Tighten to a torque of 49 N.m (36.14 lb.ft).
- Put back the hydraulic pump (see corresponding sheet).

7 - Connections

- Put into place the extension tube at exhaust exit (5) and fix using the fixing collar (4).
- Put back the motor backflow duct (6).
- Reconnect the fuel incoming and outgoing pipes (3).
- On the motor, reconnect the electric connections (2) then fix the trunking using plastic collars.
- On the motor, reconnect the battery connection wires (1).

8 - Additional operations

- Put back the cover (see corresponding sheet).
- Reconnect the « + » then « - » terminals of the starter battery.
- Put the machine back in the operational configuration.
- Start the motor and check that it works properly.

Sheet C098	CORRECTIVE MAINTENANCE SHEET	Folio 2/2
	CHANGING THE THERMAL MOTOR	

⚠ Caution!
 If the motor installed is new,
 follow the first
 commissioning instructions
 (see motor manufacturer's
 manual).

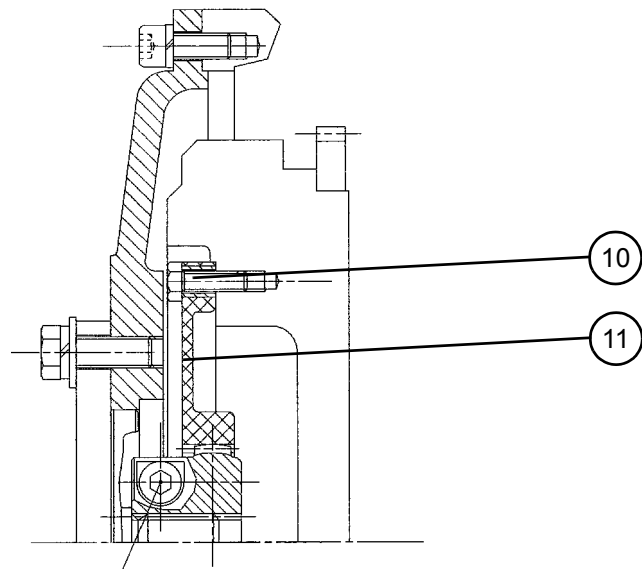
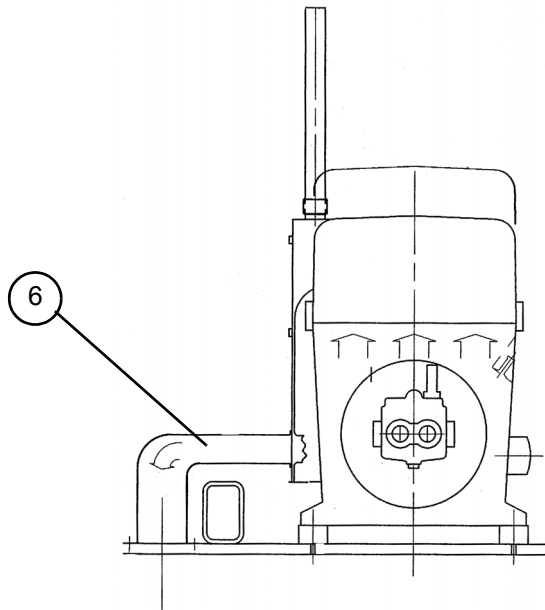

COUPLE DE
 SERRAGE 83 Nm

Sheet C099	CORRECTIVE MAINTENANCE SHEET	Folio 1/2
	CHANGING THE TURNTABLE ROTATION HYDRAULIC MOTOR	



Caution!
Put the turntable rotation blocking pin into place.



Caution!
It is essential to put the component in slings before dismantling/re-assembling it.



Caution!
Ensure that the oil is not too hot.



Caution!
Use a container to collect oil to prevent pollution of the environment.

1 - Preliminary operations

- Lift the boom sufficiently to enable access to the turntable rotation hydraulic motor.
- Place wedges under the boom to bear its weight.
- Put the machine in the maintenance configuration (see § 6.3 -).
- Switch off electric power (see § 6.4 -).
- If necessary, close the shut-off valve or empty the hydraulic tank.

2 - Removing the hydraulic motor

- Mark and disconnect the two hoses (1) of the hydraulic motor (3).

NB: *Unscrew the hoses slowly to release residual hydraulic pressure.*

- Put caps on the hoses.
- Place a wedge under the hydraulic motor.
- Remove its two fixing screws (2)
- Remove the hydraulic motor.
- Remove the blocking screws from the keyed sleeve at the end of the motor shaft.
- Remove and retain the keyed sleeve.

3 - Installing the hydraulic motor

- Put the keyed sleeve back at the end of the motor shaft (coat the blocking screw with blue loctite).
- Put a new hydraulic motor into place.
- Fix the hydraulic motor with the two fixing screws equipped with new spring washers.
- Reconnect the hydraulic hoses according to the marks made during dismantling.

4 - Additional operations

- Remove the boom wedge.
- Put the machine back in the operational configuration.
- Make several turntable rotation movements to purge the hydraulic circuit.
- Check the level of the hydraulic oil tank.

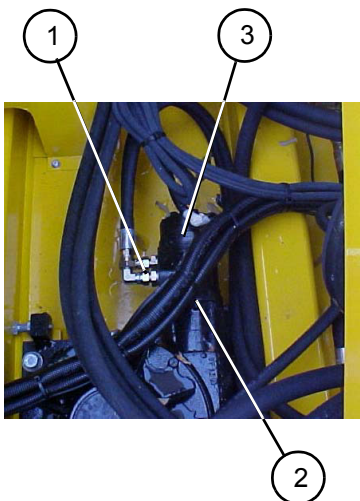

Sheet C099	CORRECTIVE MAINTENANCE SHEET	Folio 2/2
	CHANGING THE TURNTABLE ROTATION HYDRAULIC MOTOR	

Sheet C100	CORRECTIVE MAINTENANCE SHEET	Folio 1/2
	CHANGING THE SWING JOINT ASSEMBLY	

 **Caution!**
Put the turntable rotation blocking pin into place.

 **Caution!**
It is essential to put the component in slings before dismantling/re-assembling it.

 **Caution!**
Ensure that the oil is not too hot.

 **Caution!**
Use a container to collect oil to prevent pollution of the environment.

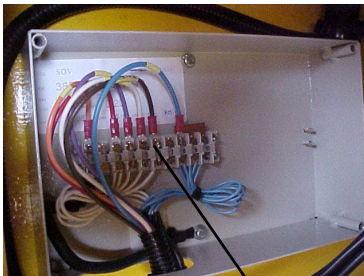

5

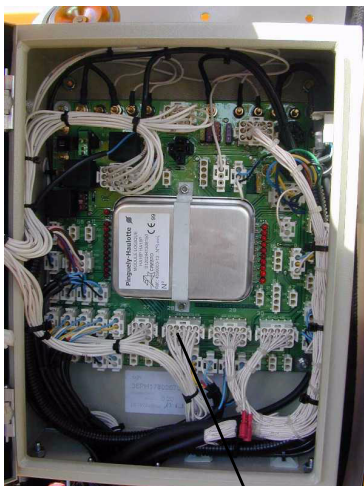

6

1 - Preliminary operations

- Lift the boom sufficiently to enable access to the swing joint.
- Place wedges under the boom to bear its weight.
- Put the machine in the maintenance configuration (see § 6.3 -).
- Switch off electric power (see § 6.4 -).
- If necessary, close the shut-off valve or empty the hydraulic tank.

2 - Removing the swing joint

- Open the chassis box, mark and disconnect all electric connectors (5).
- Open the turntable box, mark and disconnect all electric connectors (6) from the swing joint wiring harness.
- Free the two electric wiring harnesses (2) of the swing joint after marking their respective paths.
- Mark and disconnect the hydraulic caps and hoses (1) of the swing joint (3), on the turntable and below the chassis.

NB: *Unscrew hoses slowly to release residual hydraulic pressure.*

- Put caps on the hoses.
- Put the swing joint in slings.
- Remove the swing joint's stop screw (4).
- Remove the screws (7) fixing the swing joint to the chassis.
- Remove the swing joint from underneath the chassis.

3 - Installing the swing joint assembly

- Put the swing joint into place from underneath the chassis, and fix with fixing screws equipped with new nylstop nuts.
- Put back the swing joint rotation stop screw (4).
- Reconnect the hydraulic hoses and caps on the swing joint according to the marks made during dismantling.
- Pass the wiring harnesses in the machine along their original paths.
- Reconnect the electric connections in the chassis box and turntable box according to the marks made during dismantling.

4 - Additional operations

- Put the machine back in the operational configuration.
- Remove the wedges from under the boom.
- Make several steering and travel movements using all possible travel speeds to purge the hydraulic circuit.
- Check that the electric controls work properly.
- Check the level of the hydraulic oil tank.

Sheet C100	CORRECTIVE MAINTENANCE SHEET	Folio 2/2
	CHANGING THE SWING JOINT ASSEMBLY	

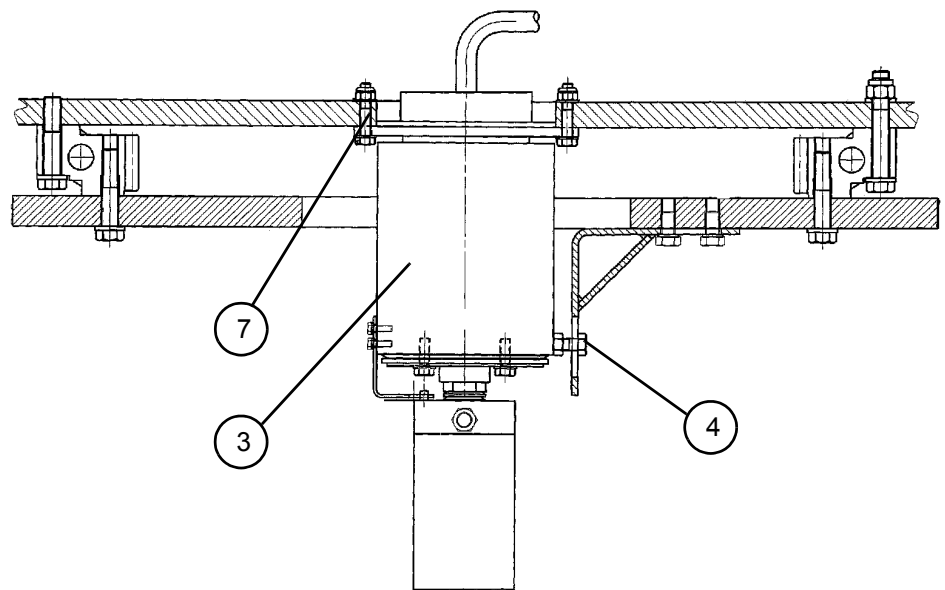
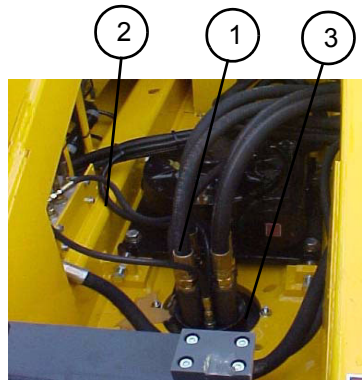

Figure 1

Sheet C101	CORRECTIVE MAINTENANCE SHEET	Folio 1/1
	CHANGING A COUNTERWEIGHT	

1 - Preliminary operations

- Put the machine in the maintenance configuration (see § 6.3 -).
- Switch off electric power (see § 6.4 -).
- Put the boom in slings (1) to prevent tipping when the counterweight(s) is(are) removed.
- Screw the lifting rings on the counterweight and secure a lifting beam to them.
- Fix a vehicle lift to the lifting beam and apply tension to the vehicle lift.



2 - Removing the counterweight

- Remove the 3 fixing screws and washers (3).
- Remove the counterweight (2).

3 - Removing the small counterweight (H23TPX, H25TPX, HB68J, HB76J)

- Remove the fixing screw from the small counterweight (4) and (6).
- Remove the small counterweight (5).

4 - Installing the small counterweight (H23TPX, H25TPX, HB68J, HB76J)

- Place the small counterweight (5) on the turntable and secure with the screws (4) and washers provided (see table of tightening torque values).

5 - Installing the counterweight

- Put the counterweight (2) on the turntable.
- Put back the 3 fixing screws and washers (see table of tightening torque values).

6 - Additional operations

- Check that the counterweight is properly secured to the machine.
- Remove the lifting rings from the counterweight.
- Remove the sling from the boom.
- Put the machine back in the operational configuration.

⚠ Caution!
Ensure that the lifting equipment is in good condition and of sufficient capacity.

⚠ Caution!
It is essential to put the component in slings before dismantling/re-assembling it.

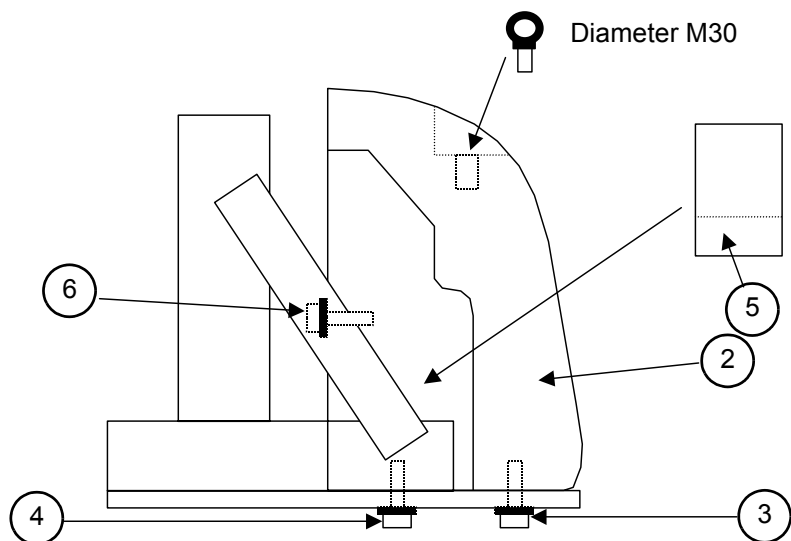

Figure 1

Sheet C103	CORRECTIVE MAINTENANCE SHEET	Folio 1/2
	DISMANTLING / RE-ASSEMBLING THE JIB	

 **Caution!**
Ensure that the oil is not too hot.

 **Caution!**
Use a container to collect oil to prevent pollution of the environment.

 **Caution!**
Ensure that the lifting equipment is in good condition and of sufficient capacity.

 **Caution!**
It is essential to put the component in slings before dismantling/re-assembling it.

1 - Preliminary operations

- Put the machine in the maintenance configuration (see § 6.3 -).
- Switch off electric power (see § 6.4 -).
- Remove contactor (7) (see corresponding sheet).

2 - Removing the platform+support assembly

- Mark and disconnect the electric connections at the platform box.
- Mark and disconnect the hydraulic hoses of the platform rotation motor and the jib cylinder hoses (1).

NB: *Unscrew the hoses slowly to release residual hydraulic pressure.*

- Put caps on the hoses.
- Open the cable passage collars on the platform and along the jib.
- Mark the path of electric cables and hoses and remove all cables passing along the jib.
- Put the platform in slings.
- Put the jib cylinder (1) and vertical elements (2) and (3) in slings.
- Remove the caps, lower pin stop rings (5), screw and stop clevis from the upper pin (5) fixing the platform assembly (4).
- Remove the screw and pin stop clevis (6).
- Remove the pin (6).
- Remove the two pins (5) and remove the platform assembly.

3 - Removing the jib

- Remove the two pins (8) fixing the jib to the jib link part, as described above, then remove the jib's vertical elements (2) and (3) and the cylinder (1).

4 - Removing the jib link part (9)

- Put the jib link part in slings (9).
- Put the receiver compensation cylinder in slings (10).
- Remove the screw and pin stop clevis (11), then remove the pin (11) from the receiver compensation cylinder (10).
- Remove the screw and rotation pin stop clevis (12) from the link part.
- Remove the rotation pin (12) then remove the jib link part (9).

5 - Installing the jib link part

NB: *Lubricate all bores before re-installing the pins.
Only use lubricants recommended by the manufacturer.*

- Check the condition of the rings of the various jib pins and replace if necessary.
- Put the jib link part back into place.
- Put back the link part rotation pin (12).
- Put back the pin stop clevis and block with its screw, previously coated in normal blue loctite 243.
- Put back the receiver compensation cylinder pin and block with the stop clevis.

Sheet C103	CORRECTIVE MAINTENANCE SHEET	Folio 2/2
	DISMANTLING / RE-ASSEMBLING THE JIB	

6 - Installing the jib

- Put the jib and its cylinder into place and put back the articulation pins.
- Put back the upper pin stop clevis (8).
- Put back the two lower pin stop rings (8), and fix with their bolts.

7 - Installing the platform+support assembly

- Put the platform+support assembly back into place and put back the 2 articulation pins (5).
- Put back the upper pin stop clevis.
- Put back the two lower pin stop rings and fix with their fixing bolts.
- Put back the pin (6) and its stop clevis.
- Pass the hydraulic hoses and electric cables along the jib, according to the marks made during dismantling, and reconnect.
- Put the cable passage collars back on the platform and along the jib.
- Put back and adjust the contactor (7) (see corresponding sheet)
- Put the machine back in the operational configuration.
- Make several jib lifting, boom lifting and turntable rotation movements to purge the hydraulic circuit.
- Check the level of the hydraulic oil tank.

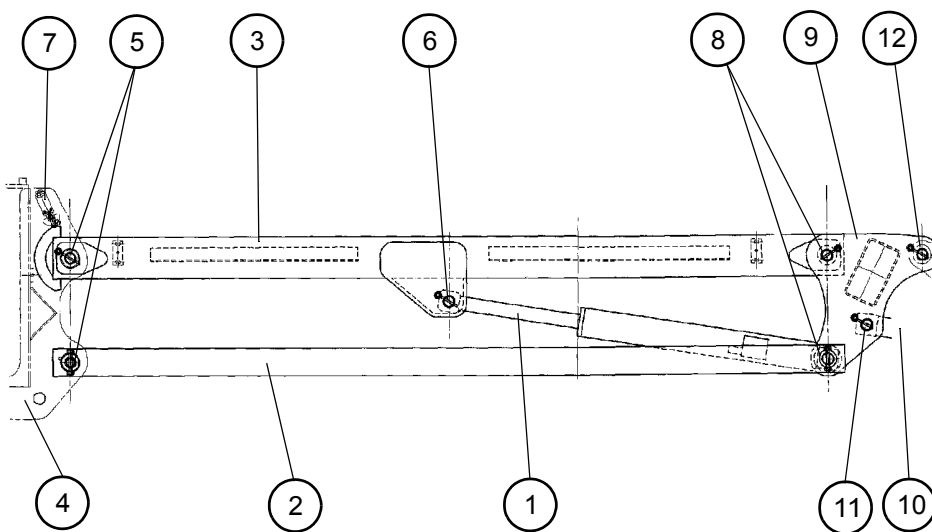

Sheet C104	CORRECTIVE MAINTENANCE SHEET	Folio 1/2
	CHANGING THE BASKET ROTATION GEARING	

1 - Preliminary operations

- Put the machine in the maintenance configuration (see § 6.3 -).
- Switch off electric power (see § 6.4 -).
- Remove the basket (see corresponding sheet).
- Remove the basket rotation hydraulic motor (see corresponding sheet).

2 - Removing the gearing

- Remove the motor fixing flange (1).
- Remove the endless screw (2) and the adjusting washers (3), if any.
- Remove the screw (4) and the toothed washer (5).
- Remove the end cap (8), then the platform link part (9) and the Nylatron washer (10).
- Remove the nylstop nut (11), bushing (12), elastic washers (13), plate (14).
- Remove the articulation pin assembly (15) then the disk (16) and pad (17).
- Remove the screws and washers (18) and (19) and remove the pin (15), wormwheel (6), keys (21), hub (20), key (7),

3 - Installing the gearing

- Change the rings, pads and keys if necessary.
- Put into place on the articulation pin (15) the key (7), hub (20) keys (21), wormwheel (6), and put back the screws and washers (18) and (19).
- Put into place the disk (16) and pad (17), then the articulation pin assembly (15).
- Put into place the plate (14), elastic washers (13), bushing (12), then a new nylstop nut (11).
- Put into place the Nylatron washer (10), platform link part (9), end cap (8) and Stauff collar.
- Fix the assembly with the screw (4) equipped with a new toothed washer (5).
- Put back the endless screw (2) and the adjusting washers (3) if necessary.
- Put back the motor fixing flange (1).
- Put back the basket rotation hydraulic motor (see corresponding sheet).
- Put back the basket (see corresponding sheet).
- Lubricate the gearing.

NB: *Only use lubricants recommended by the manufacturer.*

- Put the machine back in the operational configuration.



Caution!

It is essential to put the component in slings before dismantling/re-assembling it.

Sheet C104	CORRECTIVE MAINTENANCE SHEET	Folio 2/2
	CHANGING THE BASKET ROTATION GEARING	

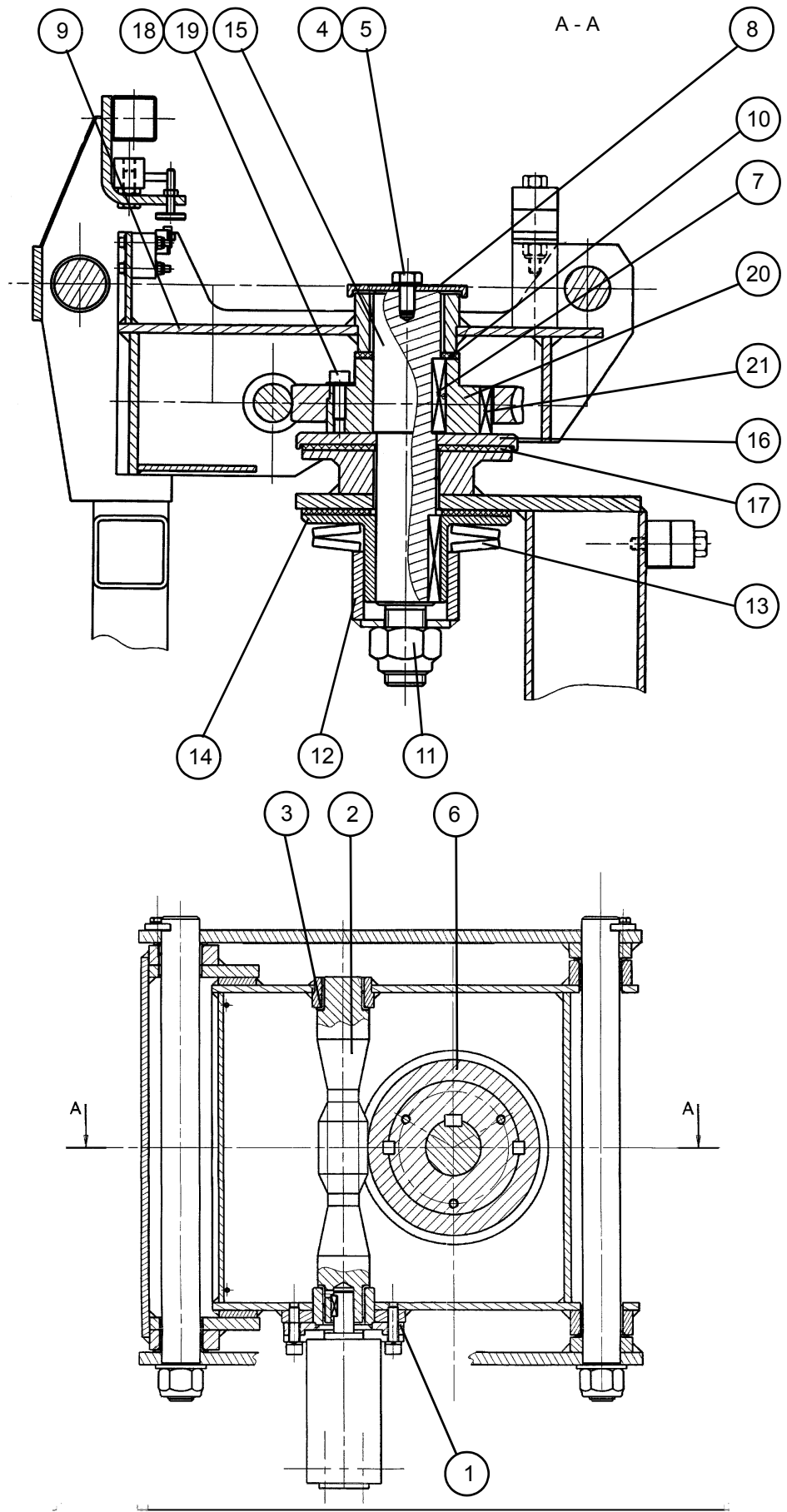

Sheet C106	CORRECTIVE MAINTENANCE SHEET	Folio 1/3
	CHANGING THE SLEW RING	

 **Caution!**
Ensure that the oil is not too hot.

 **Caution!**
Ensure that the lifting equipment is in good condition and of sufficient capacity.

 **Caution!**
Use a container to collect oil to prevent pollution of the environment.

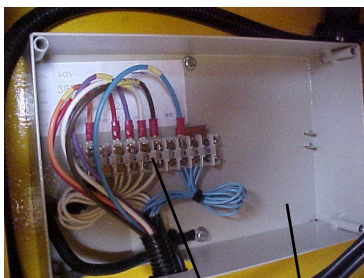

2

1

1 - Preliminary operations

- Move the turntable to the locking position.
- Put the machine in the maintenance configuration (see § 6.3 -).
- Switch off electric power (see § 6.4 -).

2 - Removing the slew ring

- Open the chassis box (1), mark and disconnect all electric connectors (2).
- Free the electric wiring harness (3) of the swing joint (4) after marking its path.
- Mark and disconnect the hoses of the swing joint (4) under the chassis (travel motor oil supply and return).

NB: *Unscrew the hoses slowly to release residual hydraulic pressure.*

- Put caps on the hoses.
- Remove the swing joint's rotation stop screw (5).
- Put the turntable in slings and unlock the turntable rotation blocking pin.
- Remove the 24 screws (6) and washers fixing the slew ring to the lower part (7) of the machine.
- Remove the turntable carefully, avoiding damage to the swing joint (4).
- Wedge the ring (8), mark its position in relation to the turntable.
- Remove the 24 screws (9), bolts (10) and washers fixing the slew ring (8) to the turntable.
- Free the turntable.

3 - Installing the slew ring

- Put the slew ring (8) into place on suitable supports in the position marked during dismantling.
- Position the turntable on the ring.
- Fix the ring with the 24 screws (9), bolts (10) and washers without pre-stressing.
- Tighten in a star pattern (see figure 2) to a torque of 27 m.daN (199 lb.ft).
- Place the turntable + ring assembly on the chassis in the locking position.
- Fix the ring (8) to the chassis (7) using the 24 screws (6) and washers without pre-stressing.
- Tighten in a star pattern (see figure 2) to a torque of 27 m.daN (199 lb.ft).
- Remove the slings from the turntable.
- Put back the rotation stop screw (5) of the swing joint (4).
- Reconnect the hoses of the swing joint (4) according to the marks made during dismantling.
- Reconnect the electric connectors (2) of the chassis box (1) according to the marks made during dismantling.
- Adjust the position of the reducing gear (11) using the adjusting screws (12) and (13):
 - Turn the reducing gear to position the ring teeth marked with a colour opposite the reducing gear pinion (this coloured mark corresponds to the most eccentric point of the ring).
 - Adjust the gap between the teeth to 300µm with a set of flakes.
 - When the gap is set, block the counter-nuts of the adjustment screws (12) and (13).

4 - Additional operations

- Put the machine back in the operational configuration.
- Lubricate the ring.

NB: *Only use lubricants recommended by the manufacturer.*

Fiche C106	CORRECTIVE MAINTENANCE SHEET	Folio 2/3
	CHANGING THE SLEW RING	

- Make several turntable rotation, steering and travel movements using all possible travel speeds to purge the hydraulic circuit.
- Check that the electric controls work properly.
- Check the level of the hydraulic oil tank.

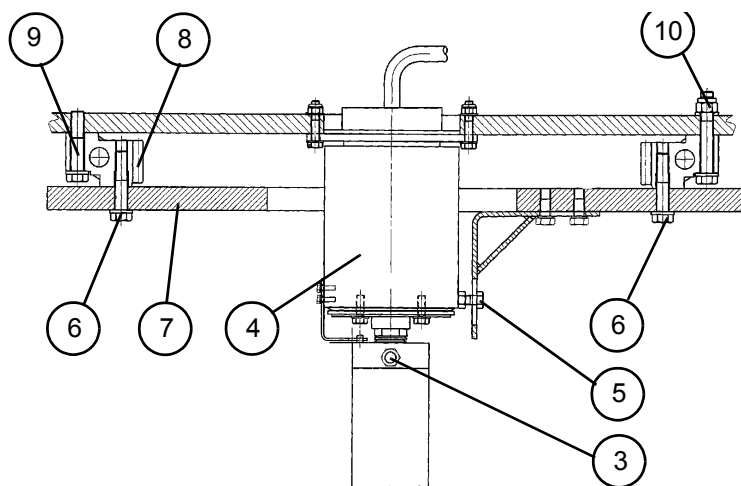

Figure 1

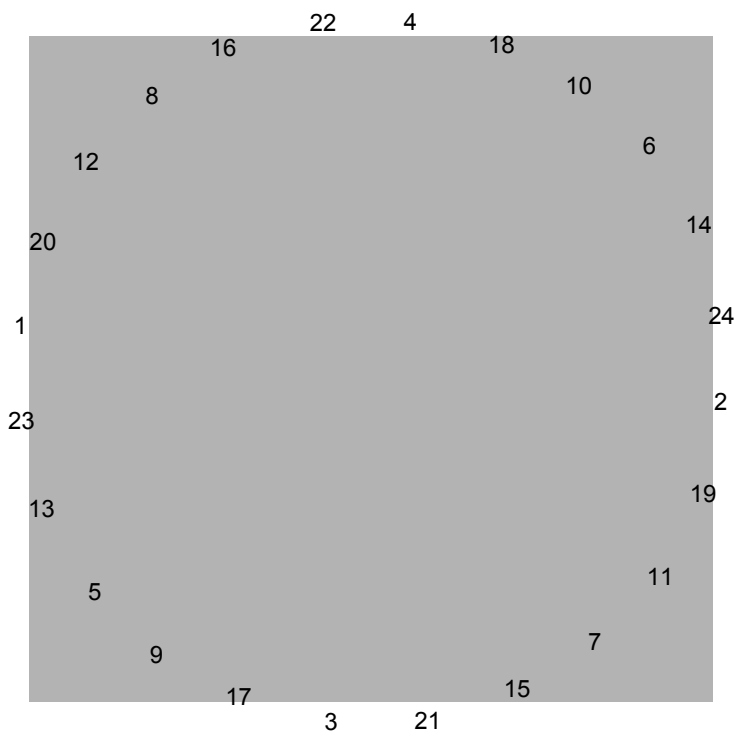
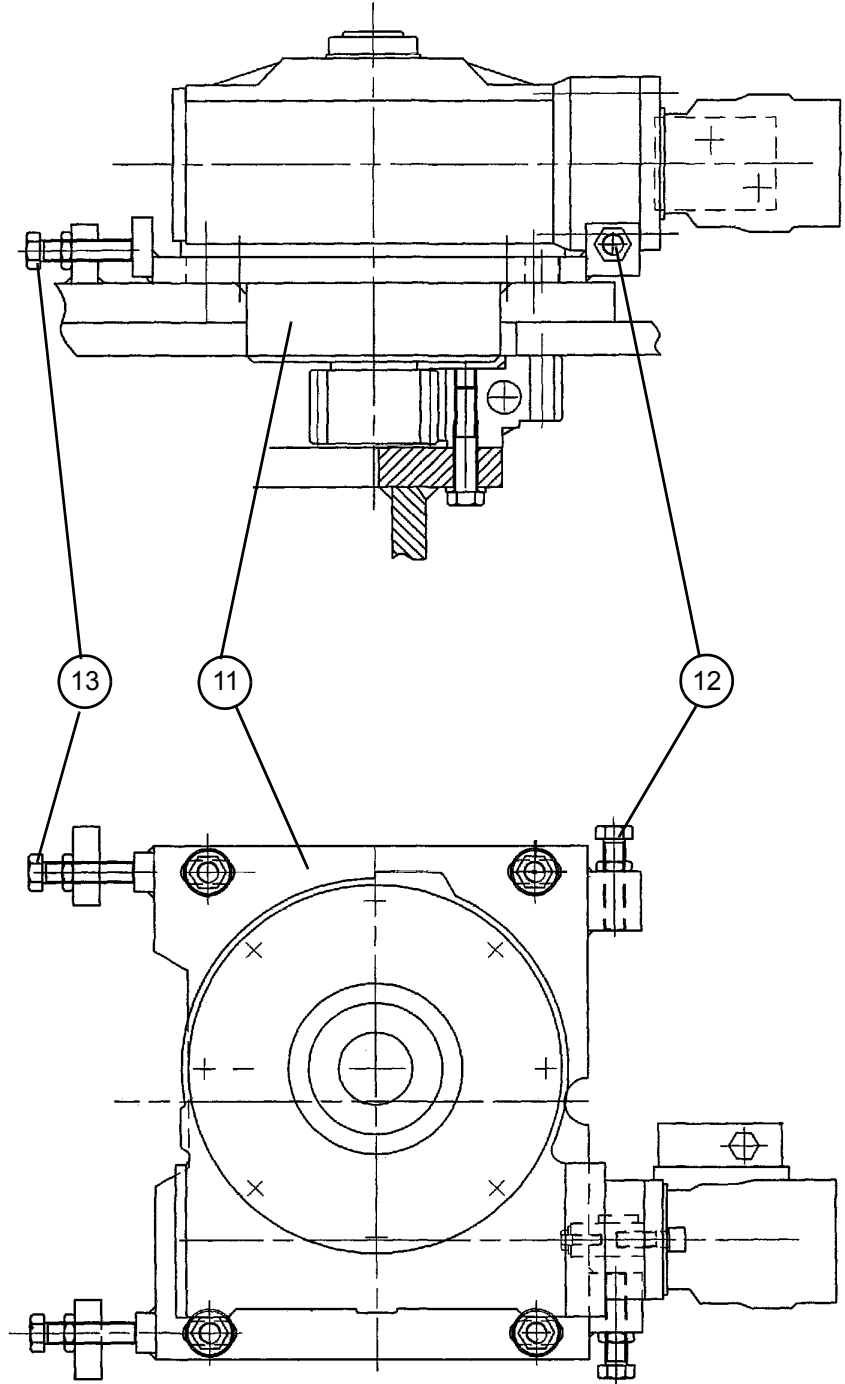
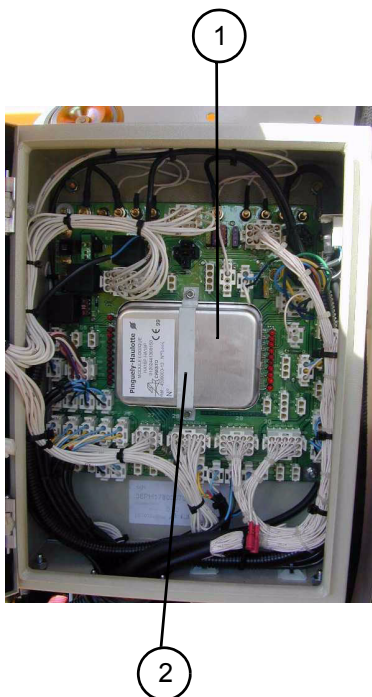

Figure 2

Sheet C106	CORRECTIVE MAINTENANCE SHEET	Folio 3/3
	CHANGING THE SLEW RING	



Sheet C107	CORRECTIVE MAINTENANCE SHEET	Folio 1/2
	CHANGING THE U1 ELECTRONIC MODULE	



1 - Preliminary operations

- Put the machine in the maintenance configuration (see § 6.3 -).
- Switch off electric power (see § 6.4 -).
- Disconnect the « - » then « + » terminals of the starter battery to isolate the electric circuit.

2 - Removing the U1 electronic module

- Open the electric box in the turntable.
- Remove the fixing flange (2) of the U1 electronic module.
- Remove the U1 electronic module.

3 - Installing the U1 electronic module

- Put into place a new U1 electronic module, previously programmed by the manufacturer.
- Put back the fixing flange.
- Close the electric box.
- Reconnect the « + » then « - » terminals of the starter battery.
- Put the machine back in the operational configuration.
- Check full operation of the U1 electronic module, using the checklist for the relevant machine.

4 - Testing the U1 electronic module

- Make all movements from the bottom control panel for two seconds.
- Make all movements from the top control panel for two seconds.
- Lift the jib (> 0°).
- Make a travel movement with the selector on high speed and check that the movement is made in micro-speed.
- Lower the jib.
- Lift the boom.
- Make a travel movement with the selector on high speed and check that the movement is made in micro-speed.
- Lower the boom.



Caution!

Computers may not be interchanged. They have a serial number corresponding to a given machine. Non-respect of this rule may result in dangerous malfunction.

Sheet C107	CORRECTIVE MAINTENANCE SHEET	Folio 2/2
	CHANGING THE U1 ELECTRONIC MODULE	

Sheet C108	CORRECTIVE MAINTENANCE SHEET	Folio 1/1
	CHANGING A CONTROL UNIT OF THE DISTRIBUTION BLOCK	

 **Caution!**
Ensure that the oil is not too hot.

 **Caution!**
Use a container to collect oil to prevent pollution of the environment.

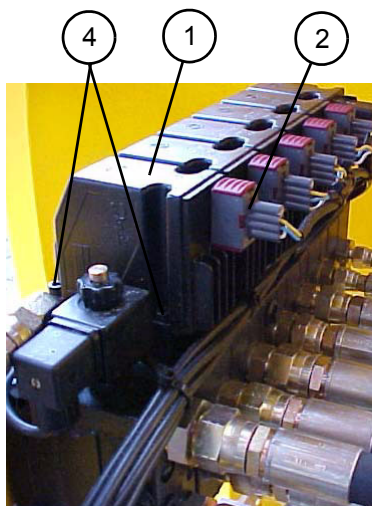

1 - Preliminary operations

- Put the machine in the maintenance configuration (see § 6.3 -).
- Switch off electric power (see § 6.4 -).

2 - Removing the coil

- Mark and disconnect the electric connections (2) of the coil (1).
- Remove the coil by removing the fixing screws (4).
- Discard the O-rings (3).

3 - Installing the coil

- Replace the O-rings.
- Put back the coil and fix using fixing screws. Tighten the screws to a torque between 7.5 and 8.5 N.m. (5.53 and 6.26 lb.ft)
- Reconnect the coil's electric connections.
- Check that there is sufficient oil in the hydraulic circuit tank.
- Put the machine back in the operational configuration.
- Test the movement corresponding to the replaced coil. Make several movements to purge the hydraulic circuit.
- Check the level of the hydraulic tank.

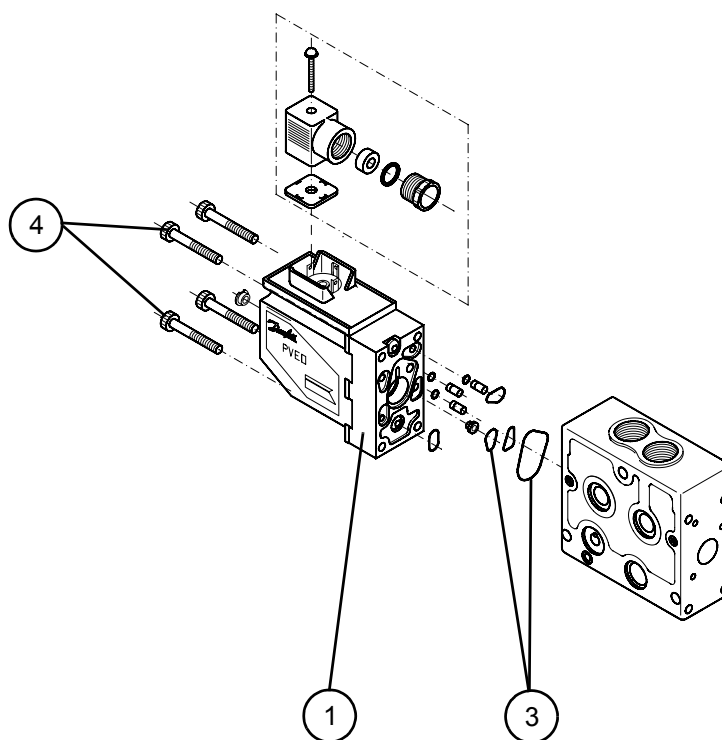

Sheet C109	CORRECTIVE MAINTENANCE SHEET	Folio 1/2
	CHANGING THE EMERGENCY ELECTROPUMP UNIT	

 **Caution!**
Ensure that the oil is not too hot.

 **Caution!**
Use a container to collect oil to prevent pollution of the environment.

1 - Preliminary operations

- Put the machine in the maintenance configuration (see § 6.3 -).
- Switch off electric power (see § 6.4 -).
- Disconnect the « - » then « + » terminals of the starter battery.

2 - Removing the emergency electropump unit

- Mark the connections and path of the electric wires (1) of the electropump unit (2).
- Disconnect the electropump unit's electric connections.
- Disconnect the electropump unit's hydraulic hoses (3).

NB: *Unscrew the hoses slowly to release residual hydraulic pressure.*

- Put caps on the hoses.
- Remove the pressure limiter (4) of the emergency hydraulic circuit (see corresponding sheet).
- Unscrew the fixing screws and remove the electropump unit.
- Mark and retain the hydraulic connectors and unions (5) screwed on the electropump unit.

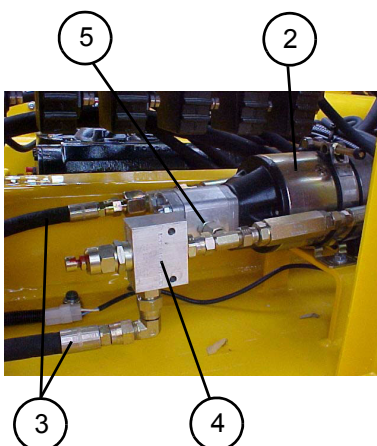

3 - Installing the electropump unit

- Put the hydraulic unions and connectors retained from the removal operation in the same places on a new electropump unit.
- Put back the pressure limiter (see corresponding sheet).
- Put the electropump back into place using the fixing screws.
- Reconnect the hydraulic hoses.
- Reconnect the electric wires according to the marks made during dismantling.
- Reconnect the « + » then « - » terminals of the starter battery.
- Put the machine back in the operational configuration.
- Do not start the thermal motor and trip the emergency electropump unit.
- Make several movements to purge the hydraulic circuit.
- Put the machine back in the operational configuration.
- Check the level of the hydraulic oil tank.

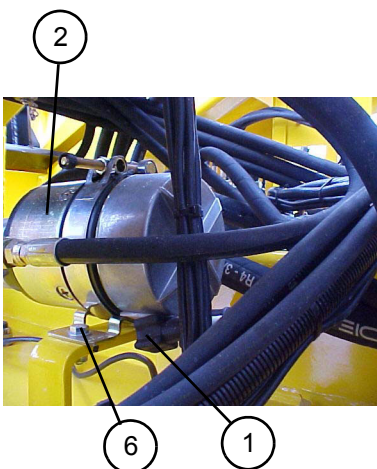

Sheet C109	CORRECTIVE MAINTENANCE SHEET	Folio 2/2
	CHANGING THE EMERGENCY ELECTROPUMP UNIT	

Sheet C110	CORRECTIVE MAINTENANCE SHEET	Folio 1/2
	CHANGING A LIMIT CONTACT	

1 - Preliminary operations

- Put the machine in the maintenance configuration (see § 6.3 -).
- Switch off electric power (see § 6.4 -).

2 - Removing a limit contact

- If necessary, remove the protective plate (4) and its fixing screws (5).
- Mark the position of the limit contact (1) and its lever (2).
- Remove the limit contact.
- Open the limit contact, mark and disconnect the electric connections.

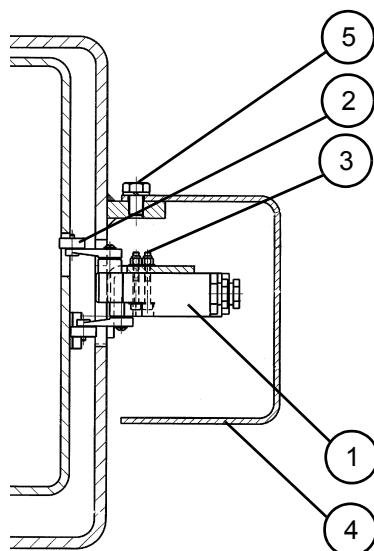

Figure 1

3 - Installing a limit contact

- Open the new limit contact, reconnect the electric connections according to the marks made during dismantling of the defective contact, then close the limit contact.
- If necessary, put the limit contact lever (2) back in the same position as that marked during dismantling.
- Put back the limit contact in the position marked during dismantling and fix using bolts (3).
- Adjust and test the contact (see paragraphs below).
- If necessary, put back the protective plate (4) and its fixing screws (5).

4 - Adjusting and testing SQ2, SQ3 and SQ9 (see chapter on positioning the safety elements)

- Put the machine back in the operational configuration.
- Make the movement corresponding to the replaced contact (see table) and check that it works.
- Adjust the position of the contact if necessary and tighten its fixing bolts.

CONTACT	MOVEMENT	CHECK
Jib 0 to 90° (SQ2)	<ul style="list-style-type: none"> • Tilt the tilt sensor 	<ul style="list-style-type: none"> • The tilt buzzer sounds if the jib is above the horizontal position. • The tilt buzzer does not sound if the jib is below the horizontal position and the machine is completely folded.
Tilt reset if machine folded (boom) (SQ3)	<ul style="list-style-type: none"> • Tilt the tilt sensor 	<ul style="list-style-type: none"> • The tilt buzzer sounds if the boom is lifted. • The tilt buzzer does not sound if the machine is completely folded.
Telescope out (SQ9)	<ul style="list-style-type: none"> • Tilt the tilt sensor 	<ul style="list-style-type: none"> • The tilt sensor sounds if the telescope is out. • The tilt sensor does not sound if the machine is completely folded.

Sheet C110	CORRECTIVE MAINTENANCE SHEET	Folio 2/2
	CHANGING A LIMIT CONTACT	

5 - Adjusting and testing SQ7 (see chapter on positioning the safety elements)

- In the telescope in position, check that there is 2 mm between the contact lever and the telescope tube as shown in figure 2.
- Remove contact SQ10 (see § 2 -).
- Put the machine back in the operational configuration.
- Lift the boom between 0° and 40°.
- Extend the telescope until SQ7 is activated. Check that the motor stops.
- Put SQ10 back (see § 3 -).

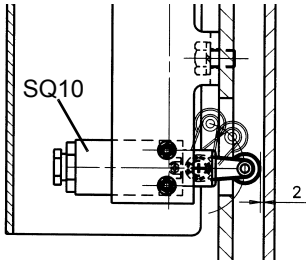

Figure 2

6 - Adjusting and testing SQ10 (see chapter on positioning the safety elements)

- In the telescope in position, check that there is 2 mm between the contact lever and the telescope tube as shown in figure 2.
- Put the machine back in the operational configuration.
- Lift the boom between 0° and 40°.
- Extend the telescope until SQ10 is activated. Check that telescope extension is stopped and that only telescope retraction is possible.

7 - Adjusting and testing SQ8 (see chapter on positioning the safety elements)

- Remove contact SQ11 (see § 2 -).
- Put the machine back in the operational configuration.
- Lift the boom above 40°.
- Extend the telescope as far as possible
- Lower the boom and check that **SQ8 is activated at 40° and that it stops the motor.**
- Put SQ11 back (see § 3 -).

8 - Adjusting and testing SQ11 (see chapter on positioning the safety elements)

- Put the machine back in the operational configuration.
- Lift the boom above 43°.
- Extend the telescope as far as possible.
- Lower the boom and check that **SQ11 is activated at 43° and that boom lowering is stopped.**

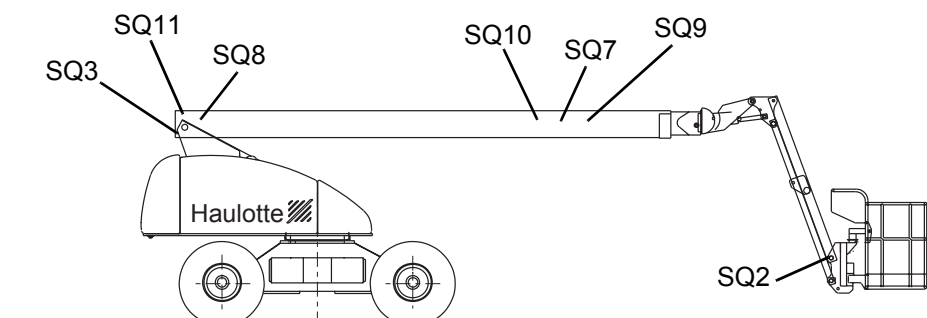

Figure 3
Position of contacts

Sheet C111	CORRECTIVE MAINTENANCE SHEET	Folio 1/2
	ADJUSTING A PRESSURE LIMITER	

 **Caution!**
Ensure that the oil is not too hot.

 **Caution!**
Use a container to collect oil to prevent pollution of the environment.

NB: Before an adjustment operation, operate the machine so that the oil in the tank is at a temperature of around 50°.

1 - Adjusting the load sensing pressure (2 - fig. 1) (standby pressure)

- Put the machine in the maintenance configuration (see § 6.3 -).
- Switch off electric power (see § 6.4 -).
- Unscrew the minimess hydraulic pressure tapping cap (3) on the distribution block and connect a pressure gauge of at least 0 to 300 bar.
- Switch electric power on again (see § 6.4 -) and start the motor.
- Without activating a movement, measure pressure on the gauge.
- Adjust the cup point hexagonal screw on the pressure limiter (2) of the hydraulic pump if necessary until the pressure gauge shows the pressure indicated in § 5.
- Put the machine in the maintenance configuration (see § 6.3 -).
- Switch off electric power (see § 6.4 -).
- Unscrew the pressure gauge and put back the hydraulic pressure tapping cap.
- Put the machine back in the operational configuration.
- Make several machine extension movements to check operation.

Figure 1

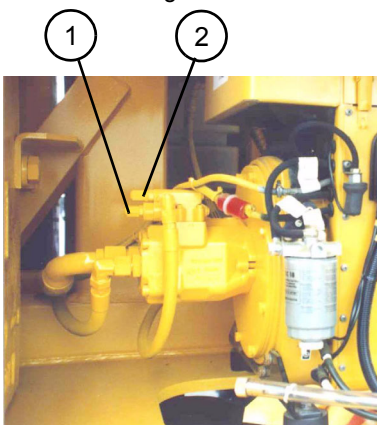

2 - Adjusting the main pressure limiter (1 - fig. 1) (flow cancellation)

- Put the machine in the maintenance configuration (see § 6.3 -).
- Switch off electric power (see § 6.4 -).
- Unscrew the minimess hydraulic pressure tapping cap (3) on the distribution block and connect a pressure gauge of at least 0 to 300 bar.
- Switch electric power on again (see § 6.4 -).
- Extend the boom lifting cylinder fully (to its stop) to block the movement.
- Activate boom lifting and measure pressure on the pressure gauge.
- Adjust the cup point hexagonal screw on the main pressure limiter (1) of the hydraulic pump if necessary so that movement is disabled at the pressure indicated in § 5.
- Put the machine in the maintenance configuration (see § 6.3 -).
- Switch off electric power (see § 6.4 -).
- Unscrew the pressure gauge and put back the hydraulic pressure tapping cap.
- Put the machine back in the operational configuration.
- Make several boom lifting movements to check operation of the machine.

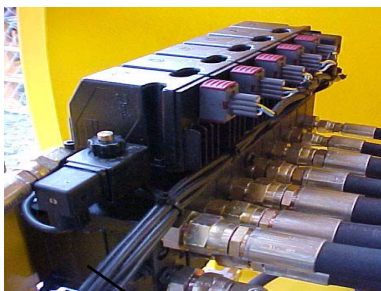

Figure 2

3 - Checking the turntable rotation pressure limiter (4 - fig. 3)

NB: Turntable rotation pressure is pre-set and must not be modified.

- Put the machine in the maintenance configuration (see § 6.3 -).
- Switch off electric power (see § 6.4 -).
- Unscrew the minimess hydraulic pressure tapping cap (3) on the distribution block and connect a pressure gauge of at least 0 to 300 bar (0 to 4351 PSI).
- Switch electric power on again (see § 6.4 -).
- Put the turntable rotation pin into place to block movement.
- Activate turntable rotation and measure pressure on the gauge.

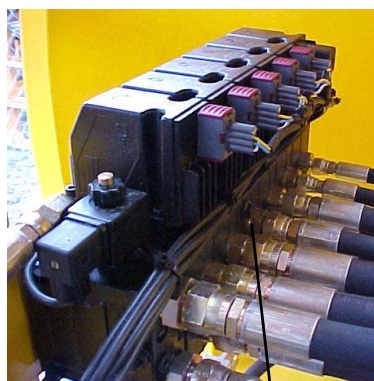

Figure 3

NB: Check both rotation directions. If measured pressure is not conform to the value in the table, replace the pressure limiter.

- Switch off electric power (see § 6.4 -).
- Unscrew the pressure gauge and put back the hydraulic pressure tapping cap.

Sheet C111	CORRECTIVE MAINTENANCE SHEET	Folio 2/2
	ADJUSTING A PRESSURE LIMITER	

- Put the machine back in the operational configuration.
- Make several turntable rotation movements to check machine operation.

4 - Adjusting the emergency unit pressure limiter (5 - fig. 4)

- Put the machine in the maintenance configuration (see § 6.3 -).
- Switch off electric power (see § 6.4 -).
- Unscrew the minimes hydraulic pressure tapping cap (3) on the distribution block and connect a pressure gauge of sufficient range to measure the pressure of the emergency unit.
- Switch electric power on again (see § 6.4 -).
- Stop the thermal motor.
- Trip the emergency electropump unit from the bottom control panel.
- Measure pressure on the gauge.
- Adjust the cup point hexagonal screw on the emergency motorpump unit pressure limiter (5) if necessary, so that movement is disabled at the pressure indicated in § 5.
- Switch off the emergency electropump unit.
- Switch off electric power (see § 6.4 -).
- Unscrew the pressure gauge and put back the hydraulic pressure tapping cap.
- Put the machine back in the operational configuration.

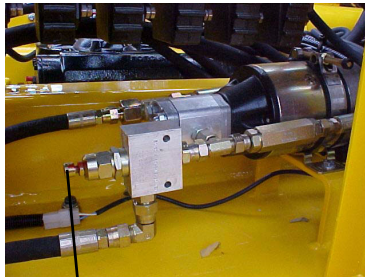

5

Figure 4

5 - Calibration pressure (in bar and PSI)

- Pump:
 - flow cancellation: 240 b (3480 PSI)
 - load sensing, standby pressure: 30b (435 PSI)
- PVG Danfoss distributor:
 - input pressure protection: 270 b (3916 PSI)
 - rotation pressure limiter: 100 b (1450 PSI)
- Telescoping:
 - extension pressure: 100 b (1450 PSI)
 - large chamber braking valve: 210 b (3045 PSI)
 - small chamber braking valve: 210 b (3045 PSI)
- Lifting:
 - lowering pressure: 100 b (1450 PSI)
 - large chamber braking valve: 210 b (3045 PSI)
- Compensation:
 - up/down braking valve: 210 b (3045 PSI)
- Jib:
 - large chamber braking valve: 210 b (3045 PSI)
- Emergency unit: 130 b (1885 PSI)

Sheet C112	CORRECTIVE MAINTENANCE SHEET	Folio 1/1
	CHANGING A BALANCING BLOCK BOOM LIFTING FUNCTION	



Caution!

The boom MUST be wedged (support the boom on wedges)



Caution!

Ensure that the oil is not too hot.



Caution!

Use a container to collect oil to prevent pollution of the environment.



Caution!

Balancing valves are safety elements. They are calibrated in the plant and must not be modified.

1 - Preliminary operations

- Lift the boom and wedge it.
- Switch off electric power (see § 6.4 -).

2 - Removing the balancing block

- Disconnect the cylinder hoses (1).
- Disconnect the rigid pipe (4).

NB: *Unscrew the hoses slowly to release residual hydraulic pressure.*

- Put caps on the hoses.
- Unscrew the fixing screws (2) and remove the balancing block (3).
- Remove the rigid pipe connector.

3 - Installing the balancing block

- Check the condition and cleanliness of the cylinder bored block.
- Put back the rigid pipe connector on the new balancing block.
- Install the new balancing block (with new seals) on the cylinder body using the fixing screws and new grower washers.
- Reconnect the rigid pipe.
- Reconnect the hydraulic hoses.
- Put the machine back in the operational configuration.
- Make several movements using the cylinder concerned to purge the hydraulic circuit.

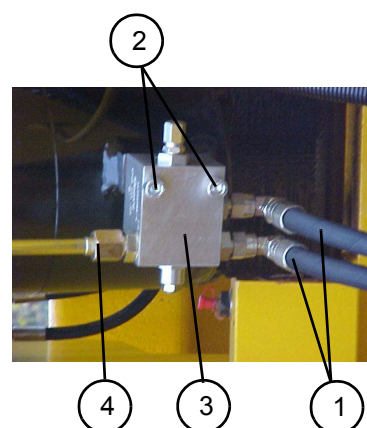

Sheet C114	CORRECTIVE MAINTENANCE SHEET	Folio 1/2
	CHANGING THE EMERGENCY HYDRAULIC CIRCUIT PRESSURE LIMITER	

 **Attention !**
Ensure that the oil is not too hot.

1 - Preliminary operations

- Put the machine in the maintenance configuration (see § 6.3 -).
- Switch off electric power (see § 6.4 -).

2 - Removing the emergency circuit pressure limiter

- Disconnect the return hose (1) of the emergency circuit at the pressure limiter (2).

 **Attention !**
Use a container to collect oil to prevent pollution of the environment.

NB: *Unscrew the hoses slowly to release residual hydraulic pressure.*

- Put a cap on the hose.
- Remove the pressure limiter (2) by unscrewing the adapter (3).
- Retain the pressure limiter's union and adapter.

3 - Installing the emergency circuit pressure limiter

- Put the union and adapter on a new pressure limiter.
- Install the pressure limiter by screwing the adapter onto the rigid pipe of the emergency motor.
- Reconnect the hydraulic hose.
- Put the machine back in the operational configuration.
- Do not start the thermal motor and trip the emergency electropump unit.
- Make several movements to purge the hydraulic circuit.
- Adjust the pressure limiter if necessary (see «adjusting a pressure limiter» sheet).
- Put the machine back in the operational configuration.
- Check the level in the hydraulic oil tank.

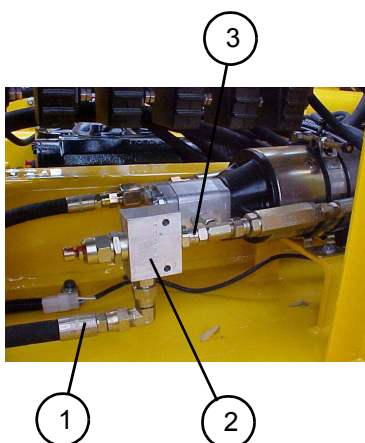

Sheet C114	CORRECTIVE MAINTENANCE SHEET	Folio 2/2
	CHANGING THE EMERGENCY HYDRAULIC CIRCUIT PRESSURE LIMITER	

Sheet C115	CORRECTIVE MAINTENANCE SHEET	Folio 1/2
	CHANGING THE JIB CYLINDER	



Caution!
Ensure that the oil is not too hot.



Caution!
Use a container to collect oil to prevent pollution of the environment.



Caution!
It is essential to put the component in slings before dismantling/re-assembling it.

1 - Preliminary operations

- Put the machine in the maintenance configuration (see § 6.3 -).
- Switch off electric power (see § 6.4 -).
- Anchor the basket on the ground.

2 - Removing the jib cylinder

- Put the cylinder (1) and jib vertical elements (2) and (3) in slings.
- Mark and disconnect the jib cylinder's two hydraulic hoses.

NB: *Unscrew the hoses slowly to release residual hydraulic pressure.*

- Put caps on the hoses.
- Remove the two bolts and pin stop rings from the cylinder pin (4) on the cylinder body side.
- Remove the pin (4).
- Remove the pin stop clevis from the cylinder pin (5) on the rod side.
- Remove the pin (5).
- Remove the jib cylinder (1).

3 - Installing the jib cylinder

NB: *Before re-installing, check the condition of all articulation pin rings and replace if necessary. Lubricate all bores before re-installing the pins. Only use lubricants recommended by the manufacturer.*

- Put the jib cylinder into place and put back the two articulation pins on the rod and body side of the cylinder.
- Put back the pin stop rings (4) and fix with their bolts.
- Put back the pin stop clevis (5).
- Remove the slings.
- Reconnect the cylinder's hydraulic hoses (1).

4 - Additional operations

- Free the basket.
- Put the machine back in the operational configuration.
- Ensure that there is oil in the hydraulic tank.
- Make several jib movements to test operation and purge the hydraulic circuit.
- Check the level of the hydraulic circuit.

Sheet C115	CORRECTIVE MAINTENANCE SHEET	Folio 2/2
	CHANGING THE JIB CYLINDER	

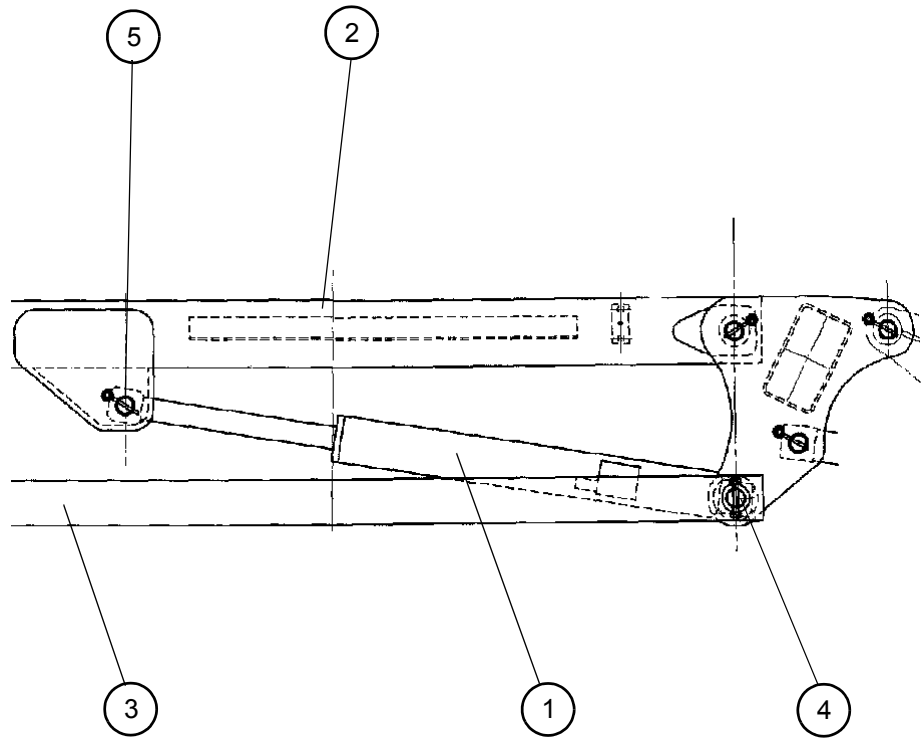

Sheet C116	CORRECTIVE MAINTENANCE SHEET	Folio 1/2
	CHANGING THE BOOM LIFTING CYLINDER	



Caution!
Ensure that the oil is not too hot.



Caution!
Use a container to collect oil to prevent pollution of the environment.



Caution!
It is essential to put the component in slings before dismantling/re-assembling it.

1 - Preliminary operations

- Position the self-propelled telescopic platform on a firm, horizontal surface.
- Put the turntable rotation blocking pin into place.
- Lift the boom to access to the boom lifting cylinder fixtures (1).
- Retract the telescope and put the jib in the low position.
- Switch off electric power (see § 6.4 -).
- Wedge the boom (place a firm support) to take its weight while the cylinder is removed (1).

2 - Removing the boom lifting cylinder

- Put the boom lifting cylinder in slings.
- Mark and disconnect the boom lifting cylinder's two hydraulic hoses.

NB: *Unscrew the hoses slowly to release residual hydraulic pressure.*

- Put caps on the hoses.
- Remove the pin stop screw (3) on the rod side of the cylinder and remove the pin (3).
- On the cylinder body side, release the counter-nuts of the pressure screws (4) then remove the pressure screws (4).
- Remove the pin (2).
- Remove the boom lifting cylinder (1).

3 - Installing the boom lifting cylinder

NB: *Before re-installing, check the condition of all the articulation pin rings and replace if necessary.
 Lubricate all bores before re-installing the pins. Only use lubricants recommended by the manufacturer.*

- Position the cylinder on the machine.
- Put back the pin on the body side (2).
- Put back the pressure screws (4) to block the pin (2). Make sure they are correctly positioned in the pin counter-bores (2).
- Block the pressure screw counter-nuts (4).
- Put back the pin (3) on the rod side, and fix with its stop screw.
- Reconnect the boom lifting cylinder's two hydraulic hoses.

4 - Additional operations

- Remove the slings from the boom.
- Ensure that there is enough oil in the hydraulic tank.
- Put the machine back in the operational configuration.
- Make several boom lifting movements to test operation and purge the hydraulic circuit.
- Check the level of the hydraulic circuit.

Sheet C116	CORRECTIVE MAINTENANCE SHEET	Folio 2/2
	CHANGING THE BOOM LIFTING CYLINDER	

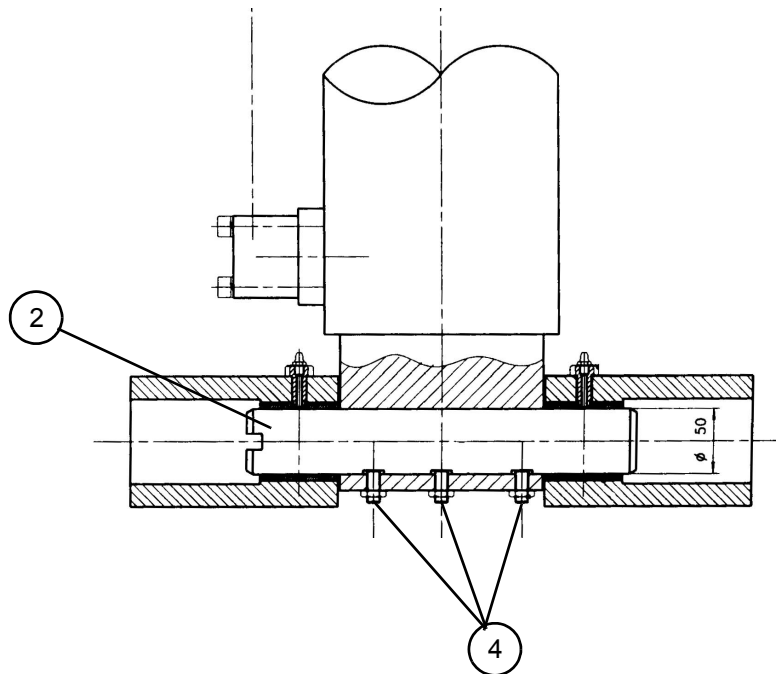
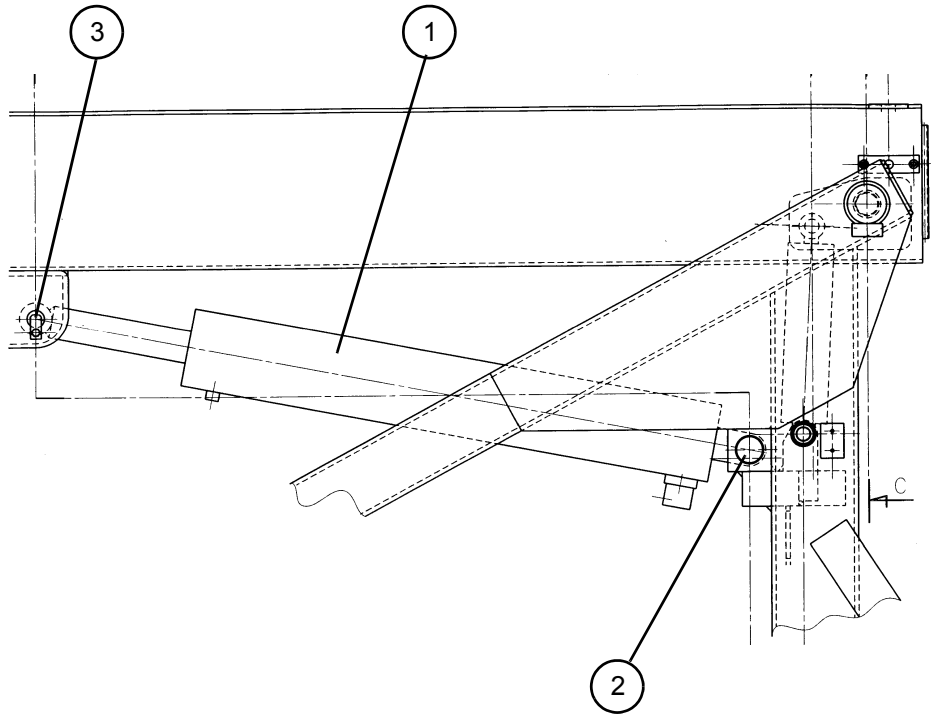

Sheet C117	CORRECTIVE MAINTENANCE SHEET	Folio 1/2
	CHANGING THE TURNTABLE ROTATION REDUCING GEAR	

1 - Preliminary operations

- Lift the boom to enable access to the turntable rotation reducing gear (1).
- Wedge the boom to take its weight (place on firm supports).
- Put the machine in the maintenance configuration (see § 6.3 -).
- Switch off electric power (see § 6.4 -).
- Remove the turntable rotation hydraulic motor (5) (see corresponding sheet).



2 - Removing the turntable rotation reducing gear

- Release then unscrew the counter-nuts and screws (2) as far as possible.
- Tighten the screws (2) as far as possible.
- Release the counter-nuts from the two screws (3).
- Unscrew the two screws (3) by a few turns, without removing them.
- Remove the four fixing screws (4) from the turntable rotation reducing gear (1).
- Put in slings then remove the turntable rotation reducing gear (1).
- Remove and retain the adjustment screws (2) with their counter-nuts.

3 - Installing the turntable rotation reducing gear

- Put back the adjustment screws (2) and (3) with their counter-nuts on the new reducing gear (without blocking them) so that the heads are as flush as possible.
- Position the new reducing gear on the turntable.
- Put back the reducing gear's four fixing screws (4) without blocking them.
- Adjust the position of the reducing gear using the adjustment screws (2) and (3):
 - Turn the reducing gear to position the ring teeth marked with a colour opposite the reducing gear pinion (this coloured mark corresponds to the most excentric point of the ring).
 - Adjust the gap between the teeth to 300µm with a set of flakes.
 - When the gap is set, block the counter-nuts of adjustment screws (2) and (3).
- Block the reducing gear's four fixing screws (4) to a torque of 196 N.m.

4 - Additional operations

- Put back the turntable rotation hydraulic motor (5) (see corresponding sheet).
- Remove the wedges from the boom.
- Put the machine back in the operational configuration.
- Make several turntable rotation movements to purge the hydraulic circuit and check reducing gear operation.
- Check the level of the hydraulic oil tank.

Sheet C117	CORRECTIVE MAINTENANCE SHEET	Folio 2/2
	CHANGING THE TURNTABLE ROTATION REDUCING GEAR	

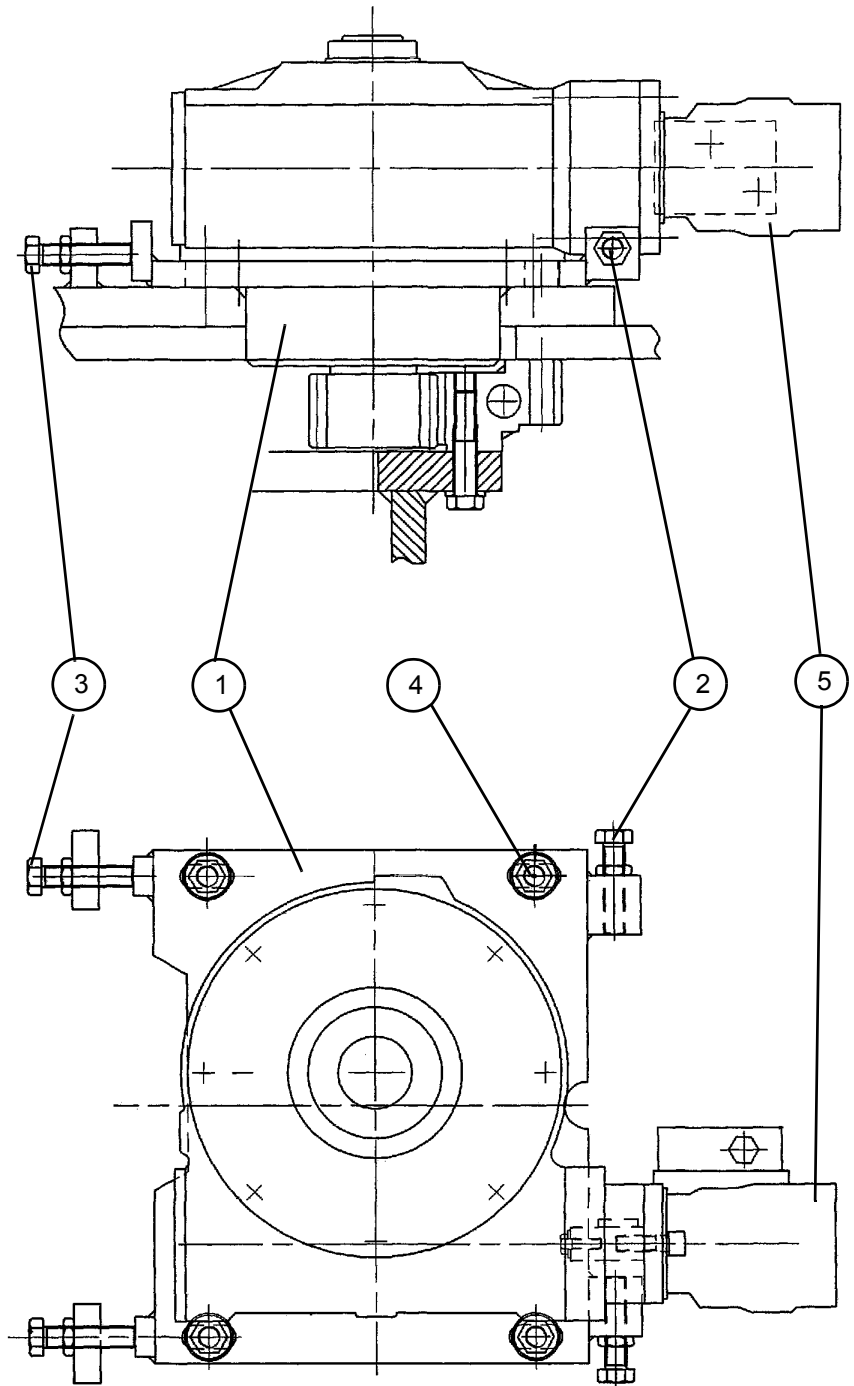

Sheet C118	CORRECTIVE MAINTENANCE SHEET	Folio 1/2
	CHANGING A CIRCUIT SELECTOR OF THE TRAVEL HYDRAULIC BLOCK	



Caution!
Ensure that the oil is not too hot.



Caution!
Use a container to collect oil to prevent pollution of the environment.

1 - Preliminary operations

- Put the machine in the maintenance configuration (see § 6.3 -).
- Switch off electric power (see § 6.4 -).

2 - Removing a circuit selector

- Remove the circuit selector (1) by unscrewing it.

3 - Installing a circuit selector

- Screw a new circuit selector whose characteristics correspond to the machine in question in the hydraulic block.
- Put the machine back in the operational configuration.
- Make several movements using the replaced circuit selector to purge the circuit.
- Check that the corresponding movement is made correctly.
- Check the level in the hydraulic oil tank.

1

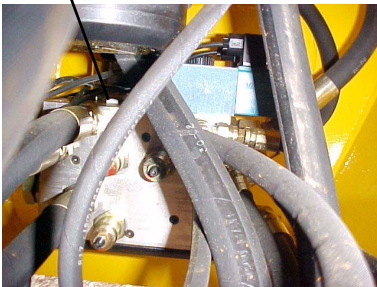

Sheet C118	CORRECTIVE MAINTENANCE SHEET	Folio 2/2
	CHANGING A CIRCUIT SELECTOR OF THE TRAVEL HYDRAULIC BLOCK	

Sheet C119	CORRECTIVE MAINTENANCE SHEET	Folio 1/13
	DISMANTLING / RE-ASSEMBLING THE BOOM	

 **Caution!**
 Ensure that the oil is not too hot.

 **Caution!**
 Ensure that the lifting equipment is in good condition and of sufficient capacity.

1 - Preliminary operations

- Put the machine in the maintenance configuration (see § 6.3 -).
- Switch off electric power (see § 6.4 -).
- Remove the platform (see corresponding sheet).
- Remove the jib (see corresponding sheet).
- Remove contactors SQ3, SQ7, SQ8, SQ9, SQ10 and SQ11 (see corresponding sheet).

2 - Remove the head element (HE) and the intermediary element (IE)

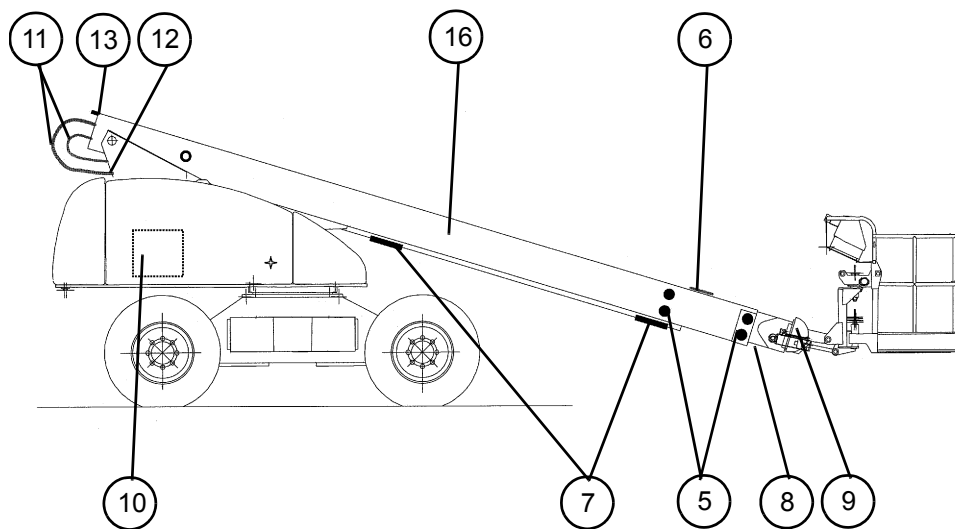

Figure 1

- With the boom lowered, marked the position of each side and top guide pad (5, Figure 1), then remove all pads, by removing their fixing screws and washers.
- Free the parachute cable (6) after noting the length of the free threaded part.

NB: *Retain the 40 cable washers.*

- Remove all flap closing plates (7) on the large drum (LD) by removing their fixing screws and washers.
- Remove the fixing screws (8) from the lower sling support pad.
- Remove the parachute half-pulley (9).
- Mark the path and connections of the wires and hoses passing in the boom.
- Disconnect all the wires of the 42-wire cable in the turntable control box (10) and remove the mains plug.
- Bind the wires together with adhesive tape (cut the wires if the cable needs replacing).
- Consult the panel's wiring diagram and make sure the necessary tools are at hand to pull out the connectors.
- Lift the boom to the horizontal position using the emergency unit.
- Free the cables and hoses fastened in the turntable by cutting the collars (replacements will be required).
- Remove the spiral protective sheaths and take the cable and hoses (11) from the turntable.
- Mark the 4 small hoses (12) and disconnect them from the connection

Sheet C119	CORRECTIVE MAINTENANCE SHEET	Folio 2/13
	DISMANTLING / RE-ASSEMBLING THE BOOM	

plate under the boom.

- Free the slings (13) after noting the length of the free threaded part.
- Take the cable and hoses from the side chutes of the large drum and allow to hang freely from the flap.
- Remove the telescope cylinder pin.
- Free the chain fixture on the large drum and pass the chain through the flap (figure below).
- Put the intermediary element (14) + head element (15) assembly into slings.
- Remove completely using lift(s), the intermediary element (14) + head element (15) assembly of the large drum (16) completely using lift(s). Stop the movement before the cable chain (17) unwinds completely (Figure 2).

NB: *Be careful of the sling support pad.*

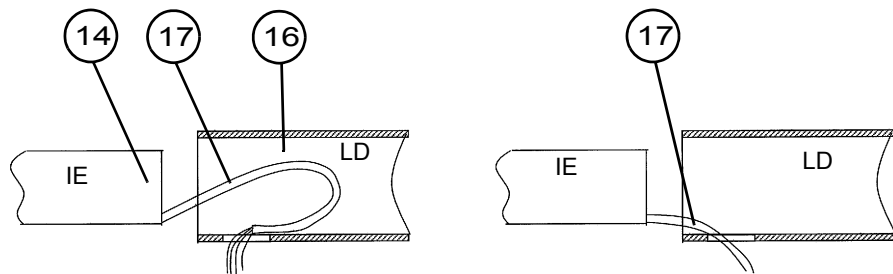

Figure 2

- Then, finish taking out the chain and the rest of the cables and hoses from the large drum.

3 - Separating the head element (15) and the intermediary element (14) (Figure 3)

- Dismantle the chain guide at the back of the intermediary element (14).
- Remove the cylinder support half-pins (19).
- Take out the cylinder (20) from the head element (15) and intermediary element (14) assembly.
- Free the slings (21) of the back pulleys by taking out the retaining Hc screws and removing the lower plate (22), then take the free strands from the outlet passages.
- Partially (~20 cm) take the head element out of the intermediary element from the front.
- After marking the positions, remove all guide pads (23) on the intermediary element (side, top and bottom).
- Take out the retaining Hc screws and remove the front pulleys (24).
- Take out the slings (25) from the front.
- Finish taking out the head element (15), assisting passage of the chain, cables and hoses.
- Replace any defective parts.
- If necessary, remove the receiver compensation cylinder.

Sheet C119	CORRECTIVE MAINTENANCE SHEET	Folio 3/13
	DISMANTLING / RE-ASSEMBLING THE BOOM	

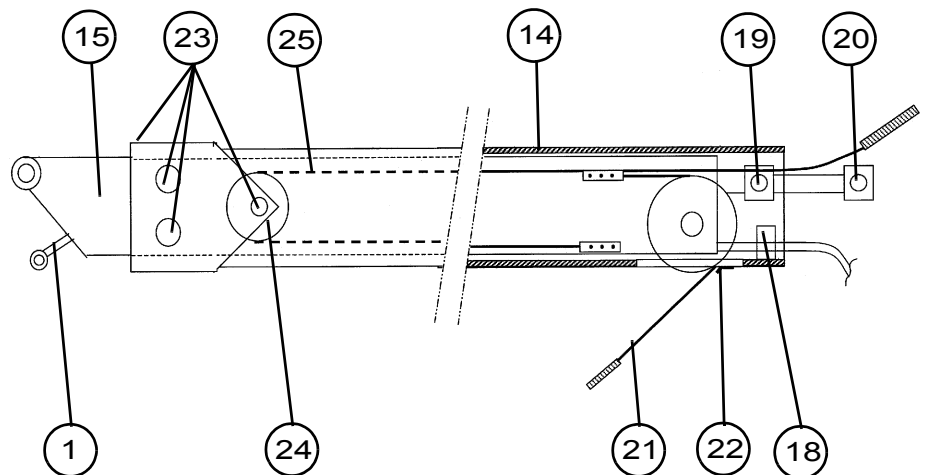

Figure 3

4 - Removing the receiver compensation cylinder (Figure 4, Figure 5)

- Put the receiver compensation cylinder in slings (1).
- Remove the top cap (2).
- Remove clevis (3) blocking the pin on the cylinder body side.
- Remove the cylinder pin (4), then take out the receiver compensation cylinder.
- Mark and disconnect the 2 hydraulic hoses of the receiver compensation cylinder (1), and remove the cylinder.
- Put caps on the hoses.

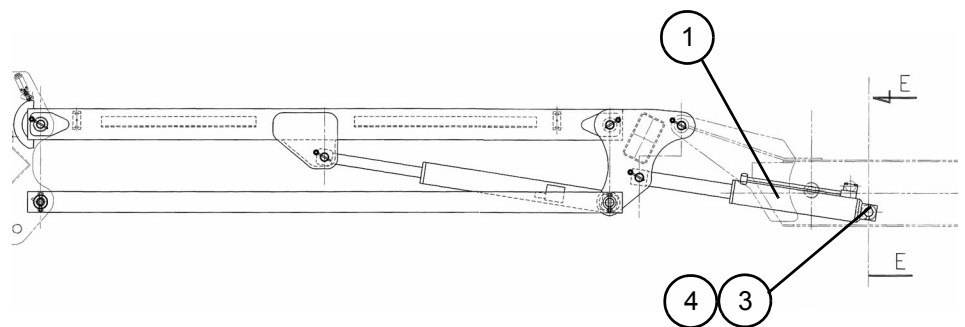

Figure 4

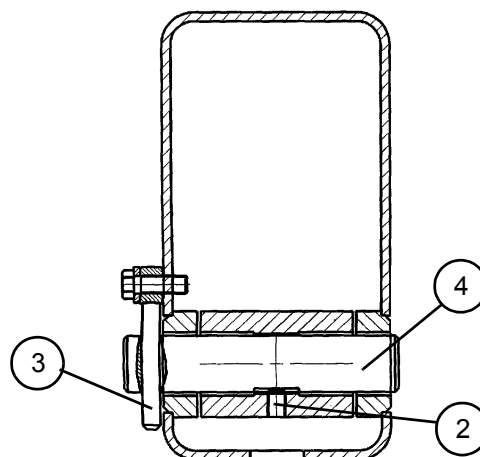

Figure 5

Sheet C119	CORRECTIVE MAINTENANCE SHEET	Folio 4/13
	DISMANTLING / RE-ASSEMBLING THE BOOM	

5 - Removing the large drum (Figure 6)

- Put the large drum (16), emitting compensation cylinder (35) and boom lifting cylinder (36) in slings.
- Mark and disconnect the hydraulic hoses of the emitting compensation cylinder and boom lifting cylinder.
- Put caps on the hoses.
- Remove the pin (37) from the boom lifting cylinder on the rod side, by removing its blocking washer and screw.
- Remove the 3 screws and nuts (39) blocking the pin (38) of the lifting cylinder on the body side, and remove the two lubricators (40).
- Remove the pin, then remove the lifting cylinder.
- Remove the pin blocking clevis (41) of the emitting compensation cylinder (35) on the rod side and remove the pin.
- Remove the pin stop plate (42) of the emitting compensation cylinder on the body side and remove the pin.
- Remove the emitting compensation cylinder.
- Remove the slotted nut (44) and washer from the boom articulation pin and remove the pin (43).
- Remove the large drum (16) and retain the 2 stop washers (45).

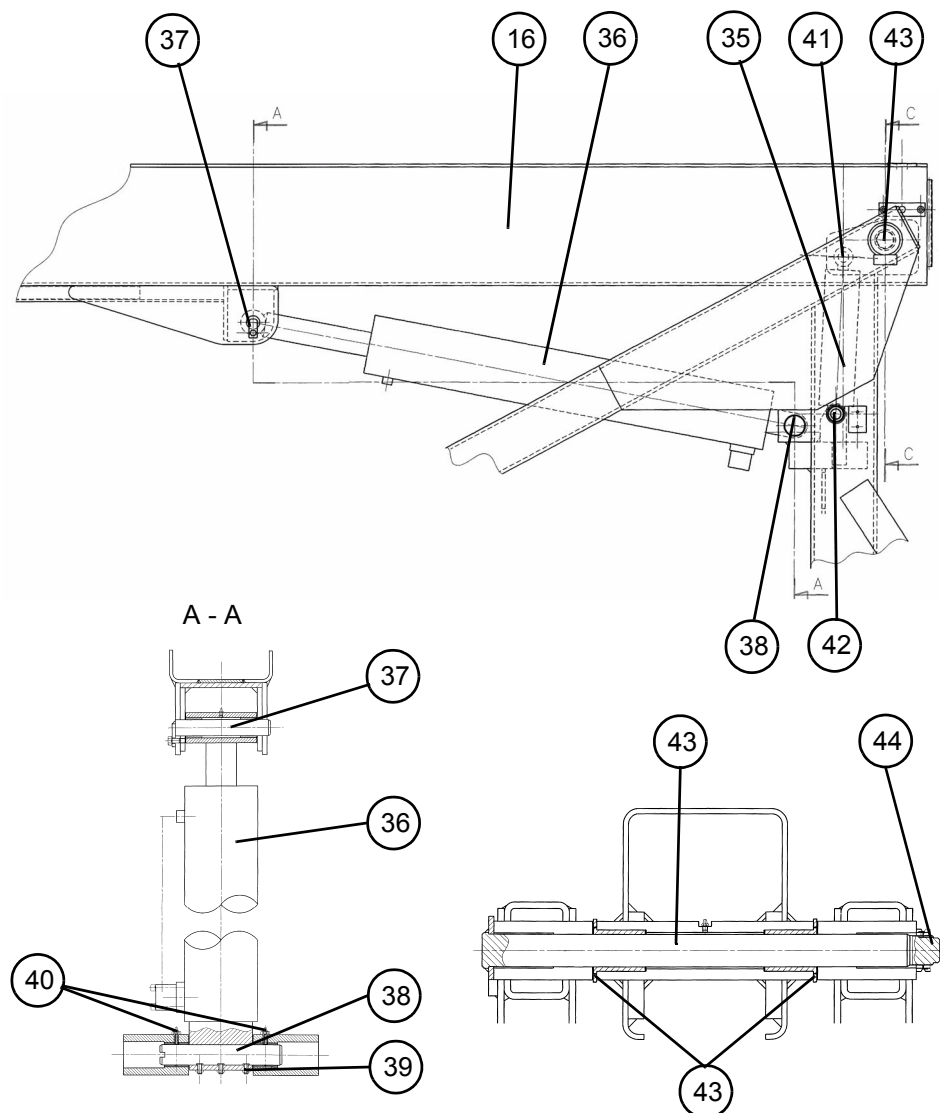

Figure 6

Sheet C119	CORRECTIVE MAINTENANCE SHEET	Folio 5/13
	DISMANTLING / RE-ASSEMBLING THE BOOM	

6 - Installing the large drum

NB: *Before re-installing, check the condition of all the articulation pin rings, and replace if necessary. Lubricate all bores before re-installing the pins. Only use lubricants recommended by the manufacturer.*

- Put the 2 stop washers into place on the large drum and install the large drum.
- Put back the boom articulation pin and block with the slotted nut equipped with a new washer.
- Put the emitting compensation cylinder into place and put back its two pins.
- Put back the pin stop plate on the cylinder body side and the blocking clevis on the rod side.
- Put the lifting cylinder into place and put back its two pins.
- Put back the 3 blocking nuts and screws of the lifting cylinder pin on the body side and the two lubricators.

NB: *Check the condition of the lubricators and replace if necessary.*

- Put back the pin blocking washer and screw of the boom lifting cylinder on the rod side.
- Reconnect the hydraulic hoses of the emitting compensation cylinder and boom lifting cylinder according to the marks made during dismantling.

NB: *Important:
Position of cables and hoses in the guide chain.
Insert the hoses and 42-wire cable in the chain, the four hoses together, arranged alternately, without the connector caps.
To make it easier, do not insert the cables and hoses in chain assemblies of more than 25 links (high friction making sliding difficult).
In cold weather, the chain is fragile and brittle.
Fasten the first link of the chain inside the head element (15); remove the upper spur on each side before assembly (see Figure 7).
Install the chain with the natural bowing downwards.
When installing the receiver compensation cylinder, connect the hoses before complete insertion in the intermediary element.
When changing the hoses, copy all the marks on the old hoses onto the new ones before installation.
Caution, most pins use a screw blocking system, either in the middle of the pin length or by an Hc screw between the two materials. Sometimes, it is necessary to grind the anti-rotation welding points, which are only used during assembly and will not need to be redone.
Before any sling movement, protect the threaded parts with the nut screwed to the end.*

Sheet C119	CORRECTIVE MAINTENANCE SHEET	Folio 6/13
	DISMANTLING / RE-ASSEMBLING THE BOOM	

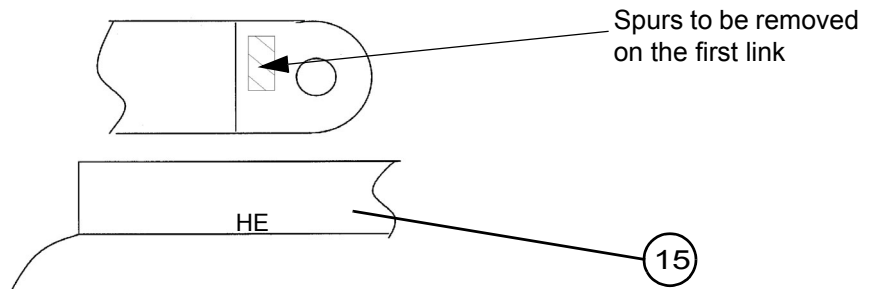

Figure 7

7 - Installing the receiver compensation cylinder

- Bring the receiver compensation cylinder to the end of the head element (1) to reconnect the two hydraulic hoses of the cylinder, according to the marks made during dismantling.
- Put back the cylinder pin (4) on the body side of the cylinder and block with the pin blocking clevis (3).
- Put back the top cap (2).

8 - Assembling the boom elements

- Put the pin into place (26).
- Prepare the slings on the head element (see Figure 8).

*NB: Hold the sling (29) in the position shown to prevent the top strand from passing under the bottom strand.
The top strand passes above the pad (27).
Leave the parachute cable (28) free.*

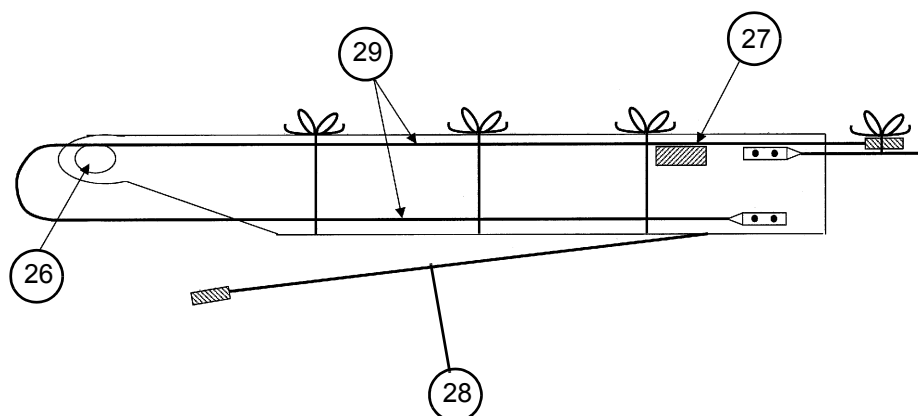

Figure 8

Head element in the intermediary (Figure 9):

- Put the isolated front pad in place (30).
- Pass the sling (25) above the pad (30) by pulling from the back.
- When passing the return slings (21) on the back pulleys, make sure they are underneath.

Sheet C119	CORRECTIVE MAINTENANCE SHEET	Folio 7/13
	DISMANTLING / RE-ASSEMBLING THE BOOM	

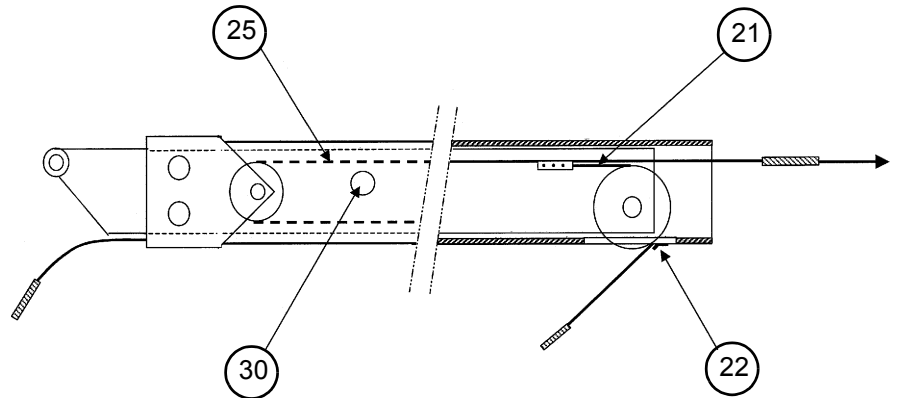

Figure 9

9 - Re-assembling and adjusting a 3-element telescopic boom

Head element equipment

- Bind together the two electric cables (31, Figure 10) with adhesive tape, on the side on which they will be inserted. Mark a length of 3m on the 42-wire cable.
- Insert the 42-wire cable via the back of the head element, passing first through a few links of the chain, then in the chute.
- Pull the cables out at the other end of the head element until the 3m mark is aligned with the collar fixing hole (fig. ?).

NB: *Align a mark (tape at 3m) with the screw hole.*

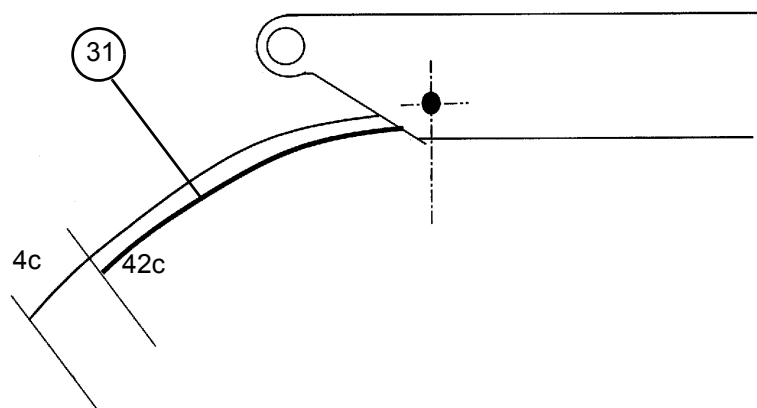

Figure 10

- Insert the 4 hoses (10) together, along the same route as the 42-wire cable (Figure 11).
- At the other end of the head element, pull the hoses through (Figure 10).

NB: *Marks on the hoses:
C1: cylinder out*

Sheet C119	CORRECTIVE MAINTENANCE SHEET	Folio 8/13
	DISMANTLING / RE-ASSEMBLING THE BOOM	

C2: cylinder in
 R1: cylinder rotation
 R2: cylinder rotation

NB: Stick the ring (31) with loctite 648.

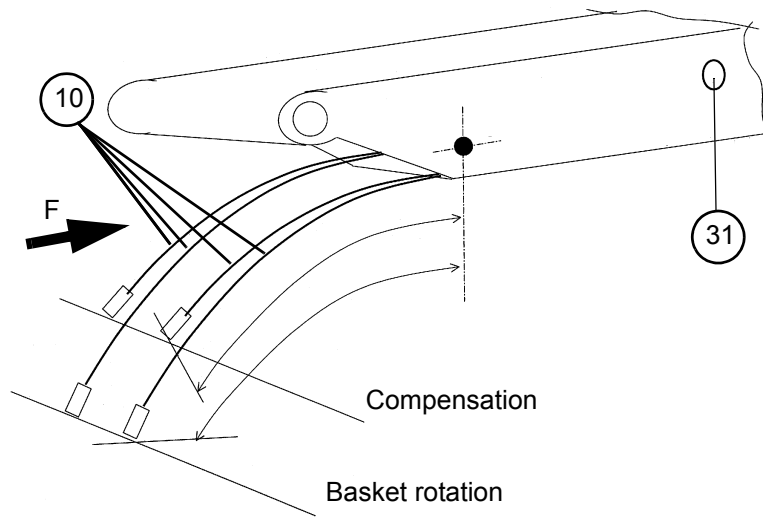

Figure 11

- Attach the cables and hoses inside the element with HB20 collars (32) for hoses C1 and R1 and HB33 collars (33) for hoses C2, R1, 4-wire and 42-wire cables (shown from F-Figure 12).

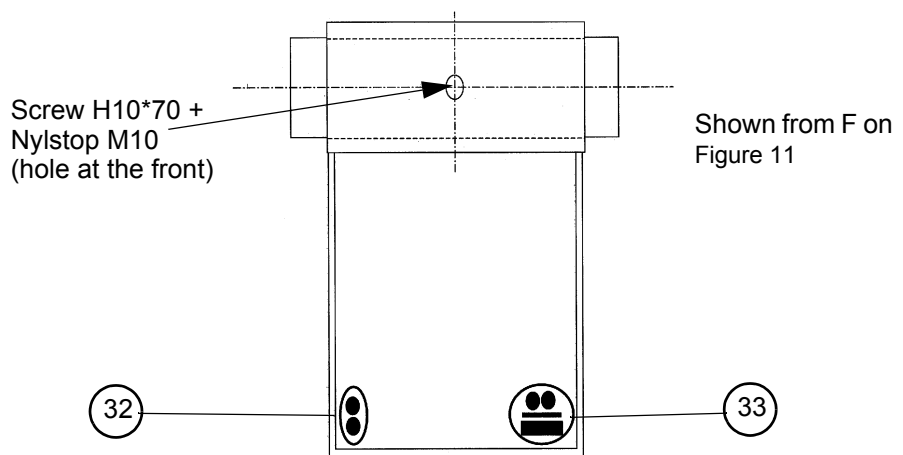

Figure 12

- Install the receiver compensation cylinder (2) after connecting the hoses (excess of 300 mm). The cylinder pin on the element is stopped by a Hc.7 screw.
- Arrange and secure the 5 slings.

10 - Assembling the equipped head element with the intermediary element

Sheet C119	CORRECTIVE MAINTENANCE SHEET	Folio 9/13
	DISMANTLING / RE-ASSEMBLING THE BOOM	

NB: 2 operators required.

Preparation of the head element before insertion:

- Attach the slings to the element with adhesive tape (such as masking tape) (Figure 13)
- Prepare the slings on the head element.
- Put the pin into place (26).

NB: Hold the out sling (29) securely in the position shown to prevent the top strand passing under the bottom strand. The top strand must pass above the pad (27). Leave the parachute cable (28) free.

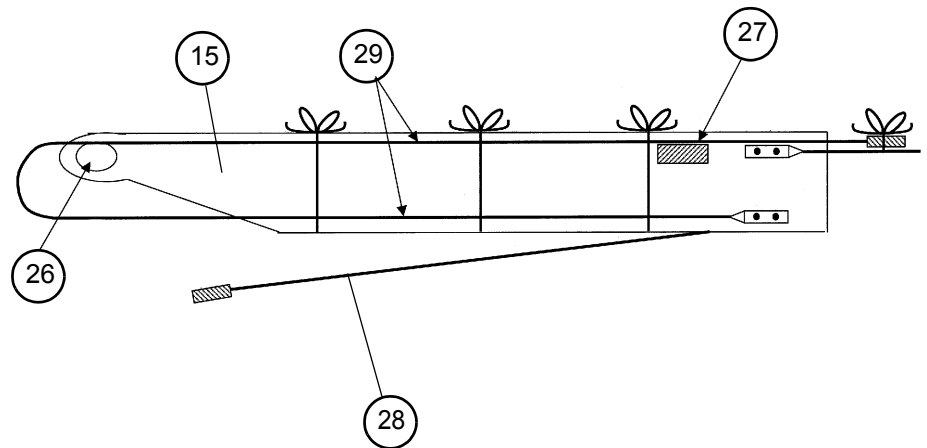

Figure 13

- Insert the cable and hoses in the intermediary element, previously aligned with the head element.
- Insert the head element in the intermediary element, assisting cables, hoses and slings in their movement. Stop movement before the head element covers the back pulleys.
- Place the in slings in the back pulley grooves and pass the strands through the outlet passages.

NB: When passing the in slings (21) on the back pulleys, make sure they are underneath.

- Bring the Hc screws forward and install the lower plate to keep the slings in the grooves. (Figure 14). Check that the back pulleys turn freely.

Sheet C119	CORRECTIVE MAINTENANCE SHEET	Folio 10/13
	DISMANTLING / RE-ASSEMBLING THE BOOM	

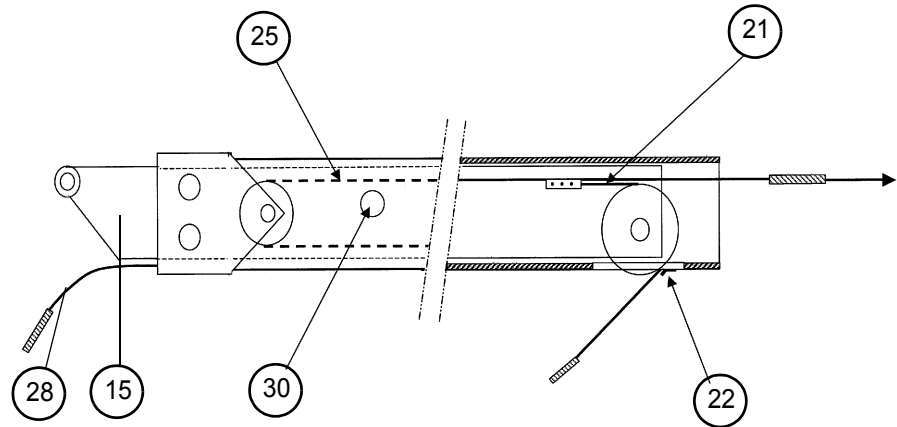

Figure 14

- Assemble the front pulleys from inside the element.
- Finish inserting the head element to its mechanical stop.
- Pull the out slings taut to place them in the front pulley groove, then put in the Hc screws to keep them in place.
- Install the side (3 on each side), top and bottom guide pads.
- Adjust the pads by balancing the lateral gap between the elements with the pad adjustment screws.
- Push all the pads against the head element, without forcing, then slacken each pressure screw by one half-turn and block the counter-nuts; do the same for the top pads, slackening each screw by one half-turn.
- Insert the telescoping cylinder in the head element.
- Install the cylinder half-pins and block them in position with Hc screws between the two materials (using threaded holes, if necessary).
- Re-install the chain guide at the back of the intermediary element.
- Complete the chain to replace missing links.

11 - Assembling the intermediary element + head element assembly in the large drum

- Put the sling support at the end of the two in slings (Figure 15).

NB: *Curve the chain before inserting the elements.
Ensure that the hoses do not fall into the chute.*

Sheet C119	CORRECTIVE MAINTENANCE SHEET	Folio 11/13
	DISMANTLING / RE-ASSEMBLING THE BOOM	

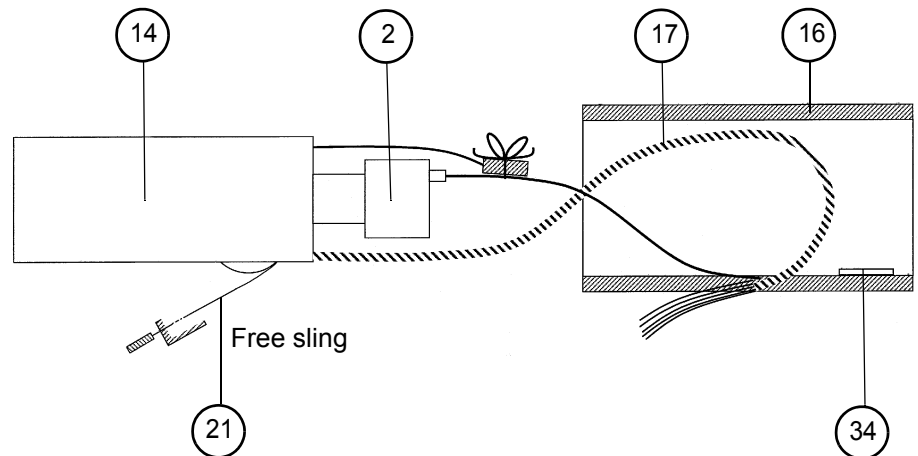

Figure 15

- Bring the head element + intermediary element assembly into alignment with the large drum.
- Insert the cables, hoses and chain in the large drum, bringing them out through the flap.
- Curve the chain (17) inside the large drum (16).
- Insert the head element + intermediary element assembly in the large drum until the cylinder clevis (2) comes opposite the pin bearing on the large drum.
- Assemble the telescope cylinder on the drum with the crossing pin, if necessary, adjusting alignment with excentric rings, and install the lateral blocking flanges.
- Insert cables and hoses in the chutes (34) inside the large drum, the 4 hoses in one and the cables in the other, then pull up all slack inside the large drum from the back.
- Fix the out slings on the large drum lifting beam and screw the nuts to the value of the free threads noted during dismantling (if the slings have not been replaced, otherwise, see «sling adjustment» on the next page).
- Connect the 4 small hoses (12) on the connection plate.
- Connect the hoses of the telescoping cylinder to the cylinder and cover the parts of the cables and hoses outside the turntable or exposed to friction with a spiral sheath.
- Fix the lower sling support pad and adjust sling tension.
- Attach the cables and hoses in the turntable with sliding nylon collars.
- Connect the 42-wire cable in the turntable control box and install the mains plug.
- Install the parachute cable half-pulley.
- Close the flaps with the appropriate plates (7).
- Install the upper and side guide pads (5) as described for the dismantling operation (§ 10, page 8).

NB: *Take care to pass slings above the pads.*

- Reconnect the parachute cable by passing through the 40 washers.

NB: *To obtain the safety elastic system, arrange the washers in opposition.*

Sheet C119	CORRECTIVE MAINTENANCE SHEET	Folio 12/13
	DISMANTLING / RE-ASSEMBLING THE BOOM	

12 - Finishing

- Put back contactors SQ3, SQ7, SQ8, SQ9, SQ10 and SQ11 (see corresponding sheet).
- Put back the jib, if applicable (see corresponding sheet).
- Put back the platform (see corresponding sheet).
- Fill the compensation hydraulic circuit by moving the platform with the manual control.
- Put the machine back in the operational configuration.

13 - Adjustments and checks before operation

- Make 2 or 3 full telescoping movements using the turntable controls.
- Set max. telescope out pressure at 100 bars if the telescope cylinder has been replaced.
- If necessary, re-adjust the guide pads, bring into contact then slacken the screws by one quarter turn for the side pads and one half-turn for the top pads.
- If necessary, re-adjust the slings (see § 14, page 12).
- Move the machine from the basket, to check all movement controls, emergency stop and motor control.
- Check the level of the hydraulic circuit.

14 - Adjusting sling tension

- Pull the out slings taut (at the back of the large drum) until the head element out movement is started (the smallest possible movement - have an observer stationed near the platform), the threaded rod sticks out of the first nut by about 54 mm.
- Pull the in slings taut (at the front of the large drum) until the head element in movement is started (compensating for the previous), the threaded rod sticks out of the first nut by about 58 mm.
- Fully extend the telescope horizontally.
- Pull the parachute cable taut without reaching the limit contact (a gap of approx. 10 mm remains).
- Check that the safety system is tripped by pulling the middle of the cable sharply downwards (motor cuts out after a time delay).
- Make 2 full telescoping movements.
- Repeat the safety system trip operation and adjust if necessary.
- Check sling tension, taking care that the telescope and intermediary element come out at the same time; if not, adjust sling tension.
- Adjust contactors SQ3, SQ7, SQ8, SQ9, SQ10 and SQ11 (see corresponding sheet).

15 - Adjusting the parachute cable and its contactor

- Extend the telescope fully and retract by 10 cm. Pull the cable sufficiently taut that it does not touch the drum.
- Extend the telescope fully again and adjust the length of the screw acting on the contactor (motor stop), so that the motor is cut out when the cable is pulled sharply. (The screw head should be about 1 cm from the contactor caster).

16 - Checking the breaking actions after re-assembling the boom on H25

- Check that the range limiter cuts out: when the boom is extended more than 16 m it cannot be lowered below 43°.
- If the first range limiter contactor fails, there is a safety contactor at 40° that cuts out the motor. In the case of a break action, use the emergency unit to retract the boom.
- Boom extension of 16m is detected by the contactor on the drum and a

Sheet C119	CORRECTIVE MAINTENANCE SHEET	Folio 13/13
	DISMANTLING / RE-ASSEMBLING THE BOOM	

cam placed on the intermediary drum. No adjustment is necessary. Simply check that the contactor does not touch the intermediary drum and that contact with the cam is made correctly.

- To adjust, first act on the 40° break then on the range limiter (43°).
-